



**BUREAU
VERITAS**

TEST REPORT AS/NZS 3100

Approval and test specification - General requirements
for electrical equipment

Report reference number: 13TH0287-AS/NZS3100_1

Date of issue.....: 2014-10-24

Total number of pages: 227

Testing laboratory name.....: **Bureau Veritas
Consumer Products Services
Germany GmbH**

Address: Businesspark A96
86842 Türkheim
Germany



Applicant's name.....: **SMA Solar Technology AG**

Address: Sonnenallee 1, 34266 Niestetal

Test specification

Standard: AS/NZS 3100: 2009; Amendment 1: 2010; Amendment 2: 2012

Certificate: **Certificate of suitability**

Test report form number.....: AS/NZS3100

Master TRF.....: Bureau Veritas Consumer Products Services Germany GmbH

Test item description: **Grid-tied battery inverter**

Trademark:



Model / Type.....: SI4.4M-11, SI3.0M-11

Ratings	SI4.4M-11	SI3.0M-11
Input DC voltage range [V]	range: 41 - 63 nom.: 48	
Input DC current [A].....	In nom.: 75 Out nom.: 63	In nom.: 51 Out nom.: 45
Output AC voltage [V].....	230 / 50Hz	
Output AC current [A]	In max.: 50 Out nom.: 14,5	In max.: 50 Out nom.: 10
Output power [VA]	3300	2300

Testing Location:	Bureau Veritas Consumer Products Services Germany GmbH		
Address	Businesspark A96, 86842 Türkheim, Germany		
Tested by (name and signature)	Alastair Schmid	<i>A. Schmid</i>	
Approved by (name and signature)	Georg Loritz	<i>Georg Loritz</i>	
Manufacturer's name	SMA Solar Technology AG		
Factory address	Sonnenallee 1, 34266 Niestetal, Germany		

Document History			
Date	Internal reference	Modification / Change / Status	Revision
2014-09-19	Ingo Röhr	Initial report was written	0
2014-10-24	Ingo Röhr	IP Test report included	1
Supplementary information:			

Test items particulars

Equipment mobility: Permanent connection
Operating condition: Continuous
Class of equipment.....: Class I
Protection against ingress of water ..: IP54 according to EN 60529
Mass of equipment [kg]: 44

Test case verdicts

Test case does not apply
to the test object: N/A
Test item does meet
the requirement: P(ass)
Test item does not meet
the requirement: F(ail)

Testing

Date of receipt of test item: 2014-02-02
Date(s) of performance of test.....: 2014-02-10 to 2014-08-11

General remarks:

The test result presented in this report relate only to the object(s) tested.
This report shall not be reproduced in part or in full without the written approval of the issuing testing laboratory.

"(see Annex #)" refers to additional information appended to the report.

"(see appended table)" refers to a table appended to the report.

Throughout this report a comma is used as the decimal separator.

This Test Report consists of the following documents:

1. Test Report
2. Additional Test Data – Annex No. 1
3. EMC Test Report – Annex No. 2
4. IP Test Report – Annex No. 3
5. Schematics, Layouts, Transformer data - Annex No. 4
6. Pictures of the unit – Annex No. 5
7. Test Equipment list – Annex No. 6

Copy of marking plate

SMA Solar Technology AG
Sonnentallee 1
34266 Niestetal
Germany
www.SMA.de

SUNNY ISLAND
Battery Inverter * Made in Germany

Model
SI 4.4M-11

Serial No.
0000000000

	U_{DC} nom	48 V
	I_{DC} in nom	75 A
	I_{DC} out nom	63 A
	U_{AC} nom	230 V
	f_{AC} nom	50 Hz
	P_{AC} nom	3300 W
	I_{AC} out nom	14.5 A
	I_{AC} in max	50 A
Power Factor cos φ		-1...+1

IP54 **Protection Class I**

SMA Solar Technology AG
Sonnentallee 1
34266 Niestetal
Germany
www.SMA.de

SUNNY ISLAND
Battery Inverter * Made in Germany

Model
SI 3.0M-11

Serial No.
0000000000

	U_{DC} nom	48 V
	I_{DC} in nom	51 A
	I_{DC} out nom	45 A
	U_{AC} nom	230 V
	f_{AC} nom	50 Hz
	P_{AC} nom	2300 W
	I_{AC} out nom	10 A
	I_{AC} in max	50 A
Power Factor cos φ		-1...+1

IP54 **Protection Class I**

SBFR5

*** 0 0 0 0 0 0 0 0 0 0 ***

*** 0 0 0 0 0 0 0 0 0 0 ***

*** 0 0 0 0 0 0 0 0 0 0 ***

SI 3.0M-11 SBFR5 04/2014

0000000000

Enclosure and user interface

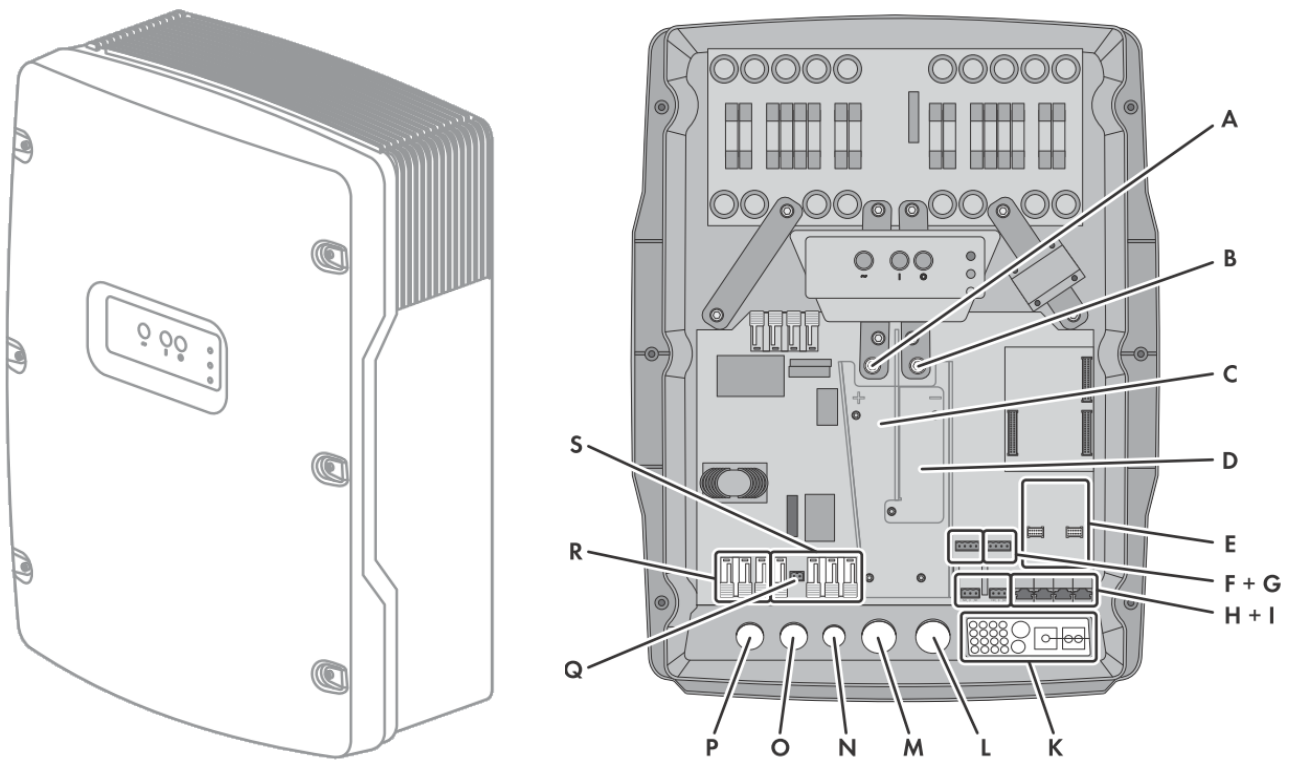

A	DC+ terminal
B	DC- terminal
C	Cable channel for DC+ cable
D	Cable channel for DC- cable
E	2 interface slots
F	BatTmp and BatCur terminals
G	BatVtg and DigIn connections
H	Relay1 and Relay2 connections
I	Communication terminal
K	Cable feed-through plate
L	Enclosure opening for DC -
M	Enclosure opening for DC+
N	Enclosure opening for PE
O	Enclosure opening for AC2
P	Enclosure opening for AC1
Q	ExtVtg connection*
R	AC1 terminal
S	AC2 terminal

Connection logic of the SI 4.4.M-11/SI 3.0M-11

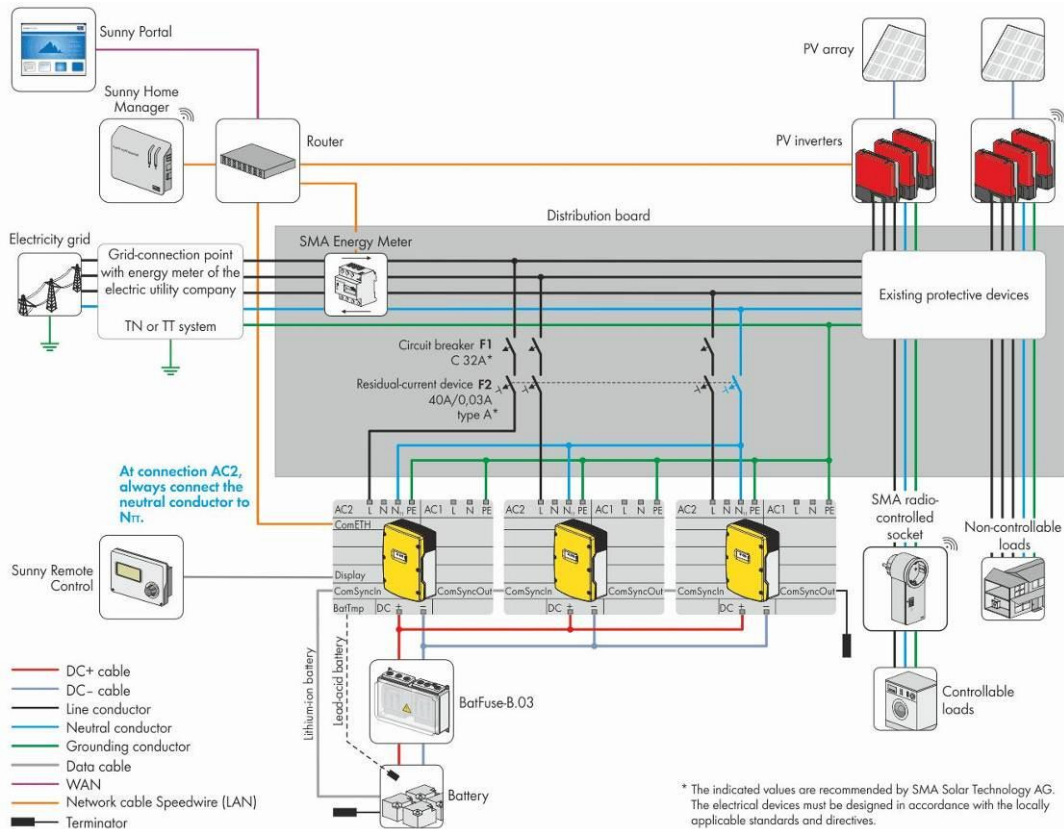
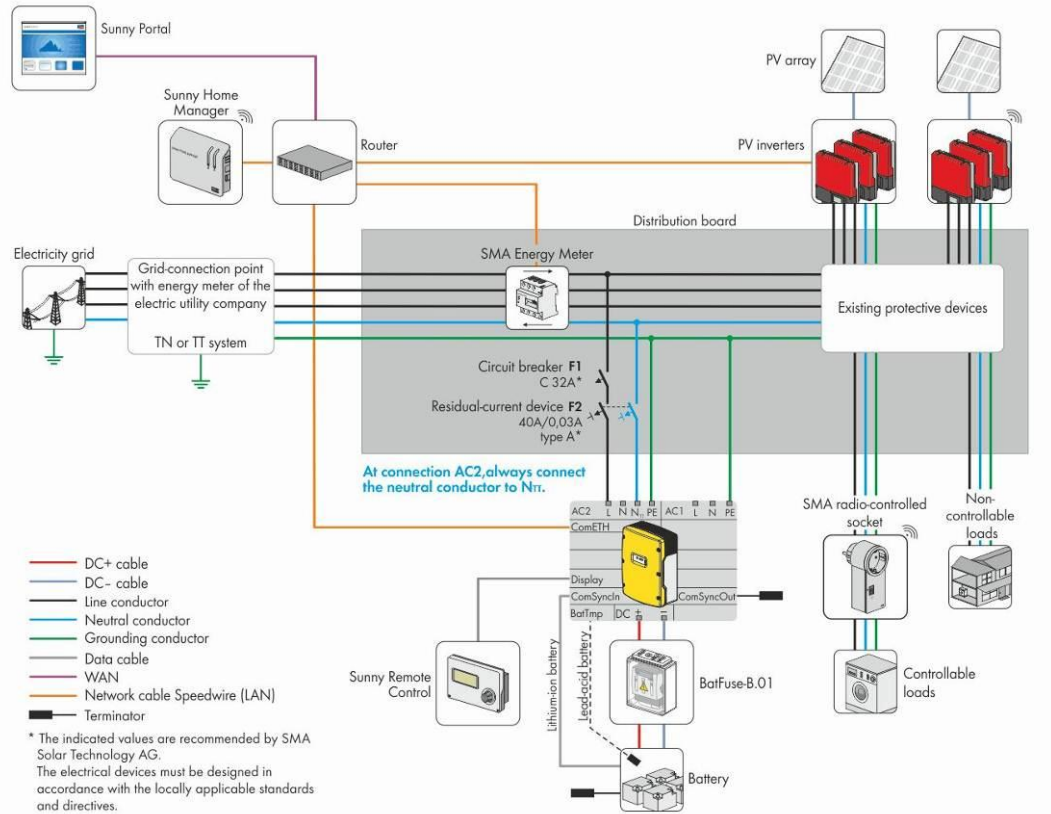

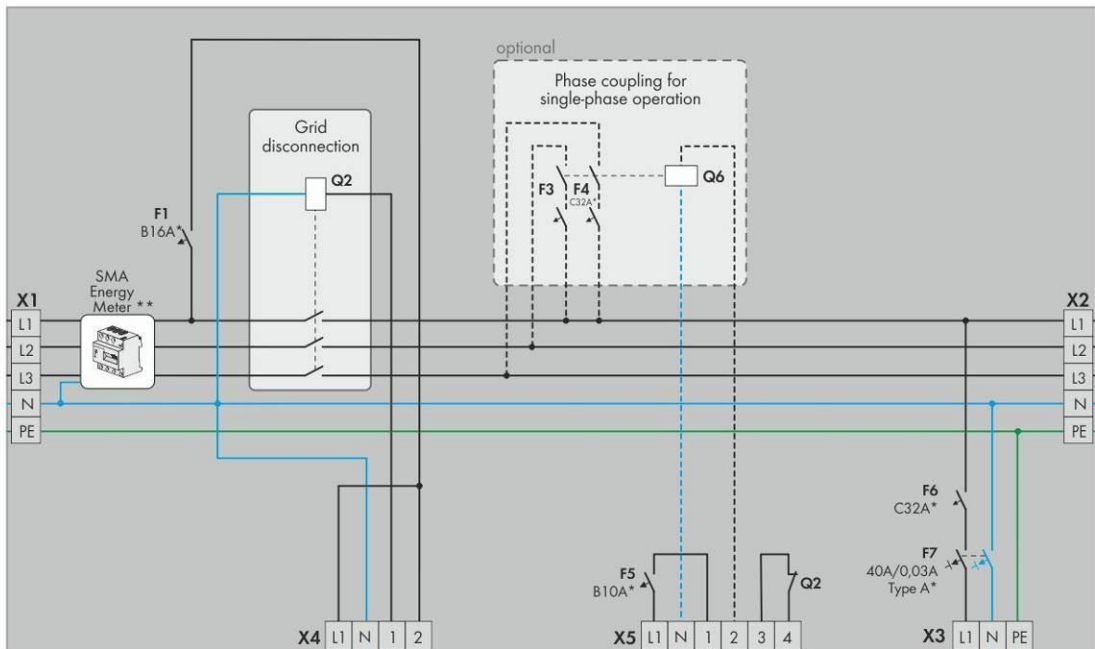
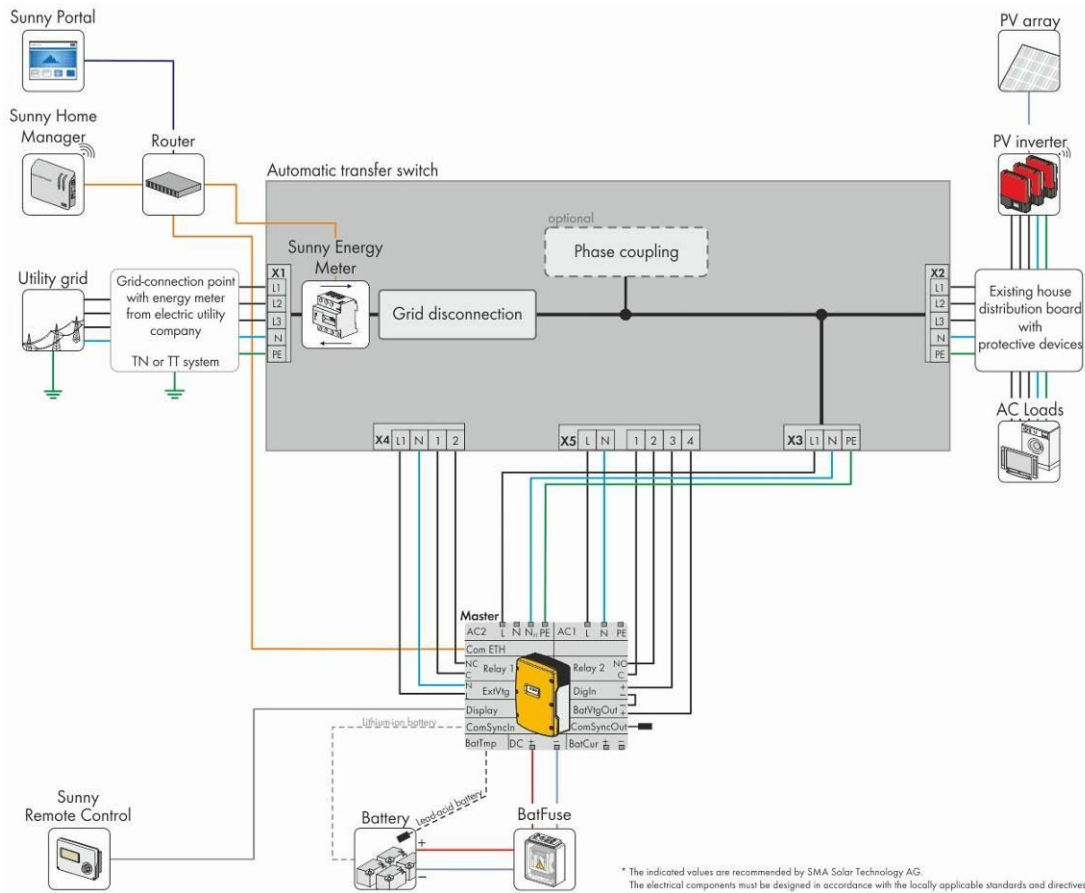

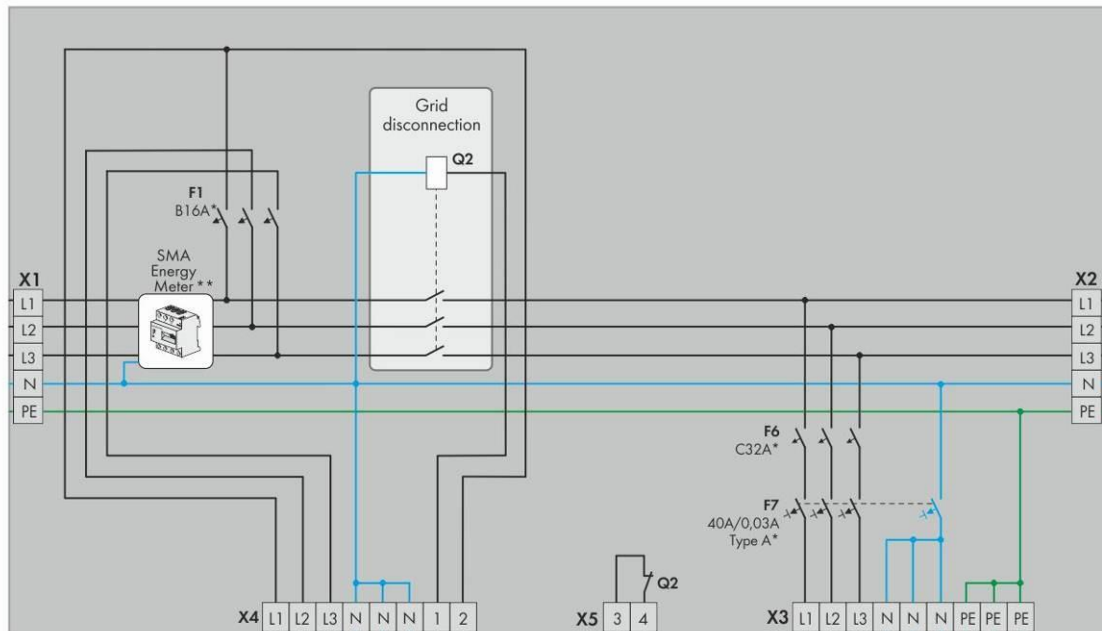
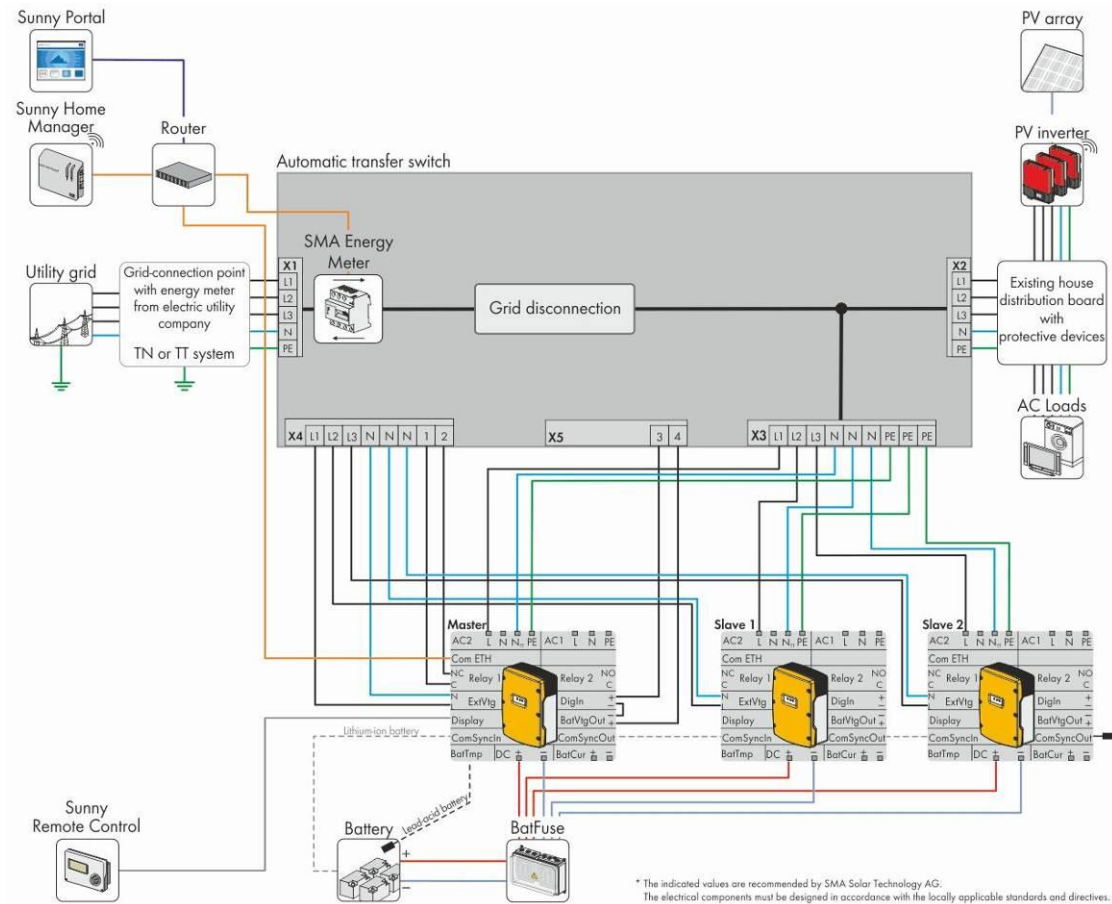

Summary of testing:

The EUT was tested to the standard AS/NZS 3100:2009 / Amendment 1: 2010 / Amendment 2: 2012.

1. The EUT was tested on a 16A protection device. The safety of the unit relies on the branch circuit of final installation. If used on a circuit greater than this, additional testing may be necessary.
2. The DC input (SELV) is insulated to the AC output by reinforced insulation (galvanic separation). The user interface for communication is insulated by reinforced insulation to AC mains.
3. The input and output terminals are fixed connected inside of the enclosure.
4. The inverter is rated class I.
5. The unit is permanently connected to DC input and to AC output. The installation instructions provide information of adequate protective devices for the final installation.
6. The power transformer provides an electrical reinforced insulation designated Class B. Compliance of the power transformer was checked by applying clause 4.1.3 Clearance and creepage and 8.4 Electric Strength of AS/NZS 3100:2009. An additional transformer datasheet is included in Annex No. 4.
7. The unit is specified for outdoor and indoor (unconditioned) use. See IP report.
8. The enclosure fulfils the requirements of an electrical, mechanical and fire enclosure.
9. The product was evaluated for a maximum ambient of 60°C. The temperature test was performed without forced air cooling.
10. The unit provides following markings:
 - "Hot surfaces"
 - "Risk of electric shock"
 - "Refer to user manual"



General product information

The battery inverter converts DC voltage from a battery into AC voltage.

- The ambient temperature range is specified as -25 to +60°C
- Dimension of EUT: 467 by 612 by 242 mm.

The inverter supplies AC loads in the grid from a battery or charges the battery with the energy provided by sources on the AC side. AC sources in the grid supply loads and are used by the battery inverter to recharge the battery. In order to increase the availability of the grid and reduce the battery capacity, the Sunny Island can use and control external energy sources (e.g. a generator) as an energy reserve. The Sunny Island supplies the loads with active power and reactive power. The battery system must be a TN or TT system. The Sunny Island does not support IT systems.

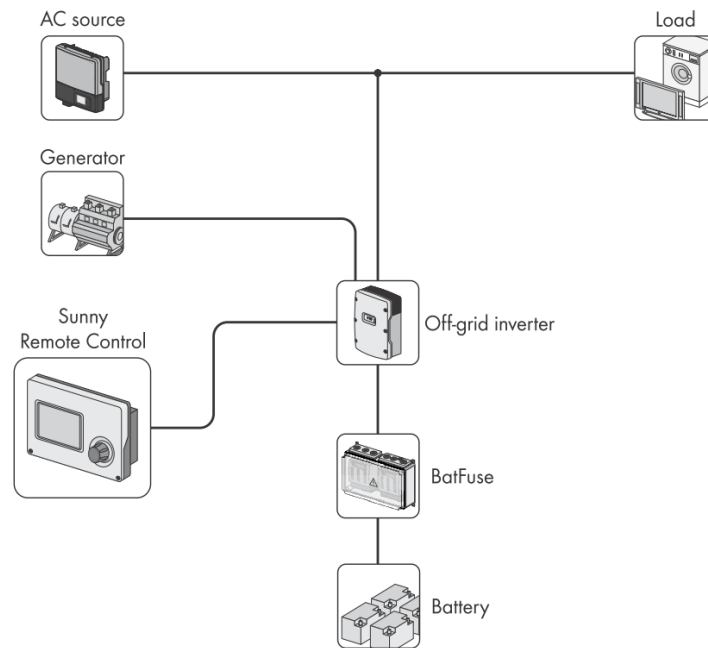

Block diagram:

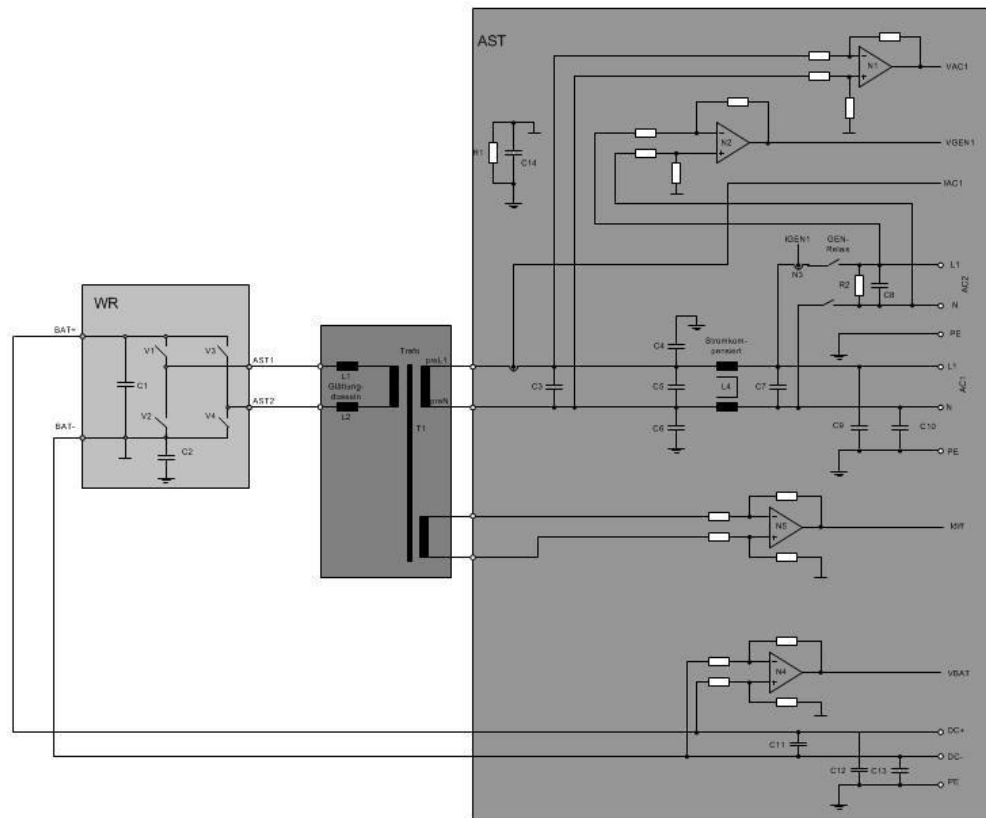

The product with serial number (1262000024) was tested on

hardware version:

SIBFS33.BG1 5514 A1
SIWRS-01 0000041 Q1
SIAST50-48S 0000024 A1

software version:

2.527

All tests were performed on EUT SI4.4M-11. Tests of the EUT SI4.4M-11 not applicable for the model(s) SI3.0M-11 were performed on the concerned model(s) and a statement is given at the relevant test.

Information for Production testing:

Visual Inspection

Dielectric Testing:

AC to PE: 1,1kVac or 1,6kVdc, 1s
AC/DC to USER: 1,35kVac or 1,9kVdc, 1s
DC to PE: 1,35kVac or 1,9kVdc, 1s
AC to DC: 1,35kVac or 1,9kVdc, 1s

Performance test

Not required explicit by the standard, but recommended by Bureau Veritas.

Ground Continuity Testing:

25A, 1 Min. from PE to Enclosure

AS/NZS 3100:2009 / Amendment 1: 2010 / Amendment 2: 2012			
Clause	Requirement – Test	Result – Remark	Verdict
SECTION 3: DESIGN AND CONSTRUCTION			
3.1	<p>General</p> <p>All equipment shall comply with the provisions of this Standard in respect of selection of materials, design, and construction, and with the tests specified herein.</p> <p>The selection and application of materials, and the design and construction of all equipment shall be such as will ensure, as far as is reasonably possible and economically practicable, that when the equipment is standing, supported, or fixed in a normal position and operating in a normal manner, and account being taken of ordinary wear and tear and other depreciating factors that can reasonably be anticipated, no person will be exposed to risk of injury or electric shock, and there will be no unwarrantable risk of fire either</p> <p>(a) through the functioning of the equipment under conditions required by its use at rated loading; or</p> <p>(b) through the mechanical or electrical failure of any material or of the equipment itself or of any part thereof.</p> <p>This Standard does not, in general, take into account the use of equipment by young children or infirm persons without supervision, or playing with the equipment by young children.</p>	Noticed.	P
3.2	<p>Equipment to be suitable for conditions of use</p> <p>All equipment shall be of a type, design, and construction that will enable it to be installed in accordance with the National Wiring Rules and will provide protection against mechanical and electrical failure which can reasonably be expected to result from mechanical failure, or from exposure to weather, water or dampness, corrosive fumes, dust, steam, oil, high temperature or any other deleterious influences to which it will be exposed under the conditions of its use.</p> <p>Non-hygroscopic insulating materials shall be used where required in individual Standards. In other cases, hygroscopic materials may be used for insulation, provided that the materials are suitably impregnated or treated if liable to exposure to dampness. The position and fixing of the insulation shall be such as will maintain creepage distances and clearances during the normal life of the equipment. In general, timber shall not be acceptable as an insulating material except that it may be recognized in special cases where a particular grade is used for a specific purpose.</p> <p>NOTE Non-hygroscopic material is taken to be material that does not, after being conditioned in an oven at 50°C ± 5°C for 24h ± 1h and then cooled in a desiccators, absorb greater than 5% by weight of moisture during a 48 hour treatment in a humidity of 95% at a temperature of 20°C ± 5°C.</p>	Noticed.	P

<p>3.3</p>	<p>Selection of materials and parts Any material or part used in, or in the construction of, any equipment shall comply with any specific requirements set out in respect thereto in this Standard or in an individual Approval and test specification dealing with such materials or parts. Where any standard prescribes, for or in any equipment, the use of a particular kind of material or part, a material or part of another kind may be used instead, provided that its use will not introduce any risk of electric shock or fire and will not render the equipment less resistant to mechanical or electrical failure than would the use of a material or part of the kind prescribed.</p>	<p>Noticed. Refer to the list of critical components, see table 3.3</p>	<p>P</p>
<p>3.4</p>	<p>Selection of components Any component part that is used in or in the construction of any equipment and which is depended upon for safety shall comply with the appropriate requirements of any relevant individual Approval and test specification.</p>	<p>Noticed.</p>	<p>P</p>
<p>3.5</p>	<p>Workmanship All fabrication and construction shall be carried out in a thoroughly workmanlike fashion complying with the appropriate requirements of this Standard and the generally accepted principles of sound and safe practice.</p>	<p>The EUT meets the applicable requirement. The correct fabrication and construction relies in the responsibility of the manufacturer.</p>	<p>P</p>
<p>3.6</p>	<p>Fuses</p>	<p>No fuses which are intended to be replaced by the operator.</p>	<p>N/A</p>
<p>3.6.1</p>	<p>Accessibility and shrouding This Clause shall not apply to internal fuses where the arrangement and enclosure of the fuses is such that they are not intended and are unlikely to be replaced other than by appropriate servicing personnel. For all other fuses, the following provisions shall apply: (a) Every fuse incorporated in equipment shall be exposed to view or have its location clearly indicated by suitable visible marking or by instructional literature provided with the equipment. (b) Every fuse shall be in an accessible position. (c) Every fuse shall be so arranged that a person is not subject to the risk of inadvertent contact with (i) any part of a fuse that is mounted in a compartment accessible for normal routine cleaning; or (ii) live parts, when covers are removed to gain access to any fuse. Fuse carriers shall remain in position for the purpose of assessing this requirement. (d) Fuse-links, fuse-contacts and fixed contacts shall be so shielded as to protect a person from accidental contact with live metal while the fuse-carrier is being inserted or withdrawn in the normal manner.</p>		<p>N/A</p>
<p>3.6.2</p>	<p>Mounting A semi-enclosed fuse that is incorporated in equipment and is marked with the letter 'R' shall be mounted in such a manner that no earthed metal is introduced in, or adjacent to, the fusing chamber.</p>		<p>N/A</p>

<p>3.7</p>	<p>Identification of wiring For equipment other than that having a Type Z attachment insulated or covered conductors used as earthing conductors shall be coloured (a) green; or (b) green and yellow in the proportions specified in AS/NZS 3191. The colour green in combination with colours other than yellow shall be acceptable for live conductors, provided that the other colour covers not less than 30% of the surface of the conductor in any 15 mm length. The single colour green shall not be used to identify any live conductor except (i) at the discretion of a regulatory authority, where the conductor forms portion of the complex wiring of equipment; or (ii) where it is specified by an individual Approval and test specification.</p>	<p>Considered.</p>	<p>P</p>
<p>3.8.</p>	<p>Regulating devices and switches</p>		<p>N/A</p>
<p>3.8.1</p>	<p>Fixing and mounting All regulating devices and switches shall be securely fixed in position. Rotary regulating devices and rotary switches shall be so fixed or located that they cannot turn bodily during operation. No regulating device or switch shall be mounted in a position or be marked in such a manner as to incorrectly indicate the intended contact position. NOTE See Clause 5.2.2 concerning clearances between terminals and exposed conductive parts.</p>	<p>No switch provided.</p>	<p>N/A</p>
<p>3.8.2</p>	<p>Visual indications of positions Notwithstanding the requirements of an individual Approval and test specification, the different positions of regulating devices and the different positions of switches may be indicated by figures, letters or other visual means which clearly indicate the intent. If figures are used for indicating the different positions, the 'off' position shall be indicated by the figure '0' or 'OFF' and the position of any energized state shall be indicated by a higher figure. The figure '0' shall not be used for any other indication. NOTE It is intended that individual Approval and test specifications be amended to line up with the requirements of the above paragraph as the opportunity arises. Any marking provided to indicate the position of a regulating device or switch shall be visible when the device or switch is in the corresponding position.</p>		<p>N/A</p>
<p>3.8.3</p>	<p>Voltage and current limitation No regulating device or switch shall control a normal operating Voltage or current when the Voltage with which the device or switch is supplied is more than 15% in excess of the voltage at which the device or switch is rated.</p>		<p>N/A</p>
<p>3.8.4</p>	<p>Switches for transportable machinery Transportable machinery, with moving parts that may cause injury to persons, shall be fitted with a switch that operates in all live conductors so that it isolates the entire equipment from the supply.</p>		<p>N/A</p>

<p>3.8.5</p>	<p>Switches Any switch incorporated in equipment shall be a Category 1, 2 or 3 switches, as appropriate or comply with AS/NZS 61058 series, in accordance with the conditions occurring in the appliance. A Category 1 switch shall comply with the relevant requirements of AS/NZS 3133, and its 'off' position shall be marked in accordance with Clause 3.8.2 herein. A Category 2 switch shall comply with the relevant requirements of AS/NZS 3133, and its 'off' position need not be marked. A Category 3 switch shall satisfy the test requirements of Clauses 13.1(j), 13.3 and 13.4 of AS/NZS 3133, and its 'off' position need not be marked. In addition it shall be subjected to 50 operations of making and breaking the normal load current of the circuit it controls, in accordance with Clause 13.5.4 and Table 3 of AS/NZS 3133, except that where appropriate for circuits including motors, the test current and power factor shall be the equivalent current and power factor of the circuit which the switch controls, with the rotors locked. The rate of operation shall be in accordance with Clause 13.3 of AS/NZS 3133. In addition, where Category 1 and 2 switches control circuits containing motors, these switches shall be subjected to a further 50 operations. The test current and power factor shall be equivalent to the current and power factor of the circuit with rotors locked and the rate of operation shall be in accordance with Clause 12.8 of AS/NZS 3133. A Category 1 switch shall be used when (a) the equipment is intended for connection to the supply by a plug and flexible cord; (b) notwithstanding Clause 5.1, it is not usual or possible to guard live parts completely against personal contact, because of the intended use and generally accepted practice with any particular equipment; and (c) the equipment is of a type that is usually left connected to the outlet socket indefinitely, and which has not been provided with a means to indicate whether it is energized or not. NOTE 1 The specification of a particular category of switch in an individual Standard does not necessarily preclude the use of a switch with a lower category number. NOTE 2 A Category 3 switch, tested to the above requirements, would not automatically qualify for an 'M' rating in accordance with AS/NZS 3133. For accessories, any single pole switch shall be in the active conductor.</p>		<p>N/A</p>
<p>3.8.6</p>	<p>Electronic regulating devices and switches Electronic thermostats and electronic switches without a mechanical switch in the main circuit may not provide a reliable off-state. Therefore the circuit on the load side shall be considered to be live.</p>	<p>No such devices present.</p>	<p>N/A</p>

<p>3.9</p>	<p>Socket-outlets Socket-outlets shall not be permitted in equipment intended for connection by flexible cord except in the following circumstances: (a) Where specifically accepted by an approvals authority in those cases where there is little likelihood of cascading of similar equipment which could result in circuit overloading and extension of fault conditions. (b) Where permitted by an individual Approval and test specification or by National Wiring Rules. (c) Where the equipment is basically providing a switching or control function. This does not preclude the use of socket-outlets or other facilities for connections within the equipment.</p>	<p>No socket-outlet provided.</p>	<p>N/A</p>
<p>3.10</p>	<p>Equipment intended to be supported by contacts of socket-outlets Appliances having integral pins for insertion into socket outlets shall comply with Appendix J of AS/NZS 3112.1</p>	<p>The EUT is not intended to be supported by contacts of socket-outlets.</p>	<p>N/A</p>
<p>3.11</p>	<p>Static charge in equipment Attention is drawn to the hazard of shocks caused by the build-up of electrostatic charge in equipment such as hand-held tools. AS/NZS 1020 gives guidance on the control of undesirable static electricity.</p>	<p>The EUT is not a hand-held equipment.</p>	<p>N/A</p>
<p>3.12</p>	<p>Control methods For equipment suitable for connection to the supply mains, asymmetrical control of the input current is prohibited in normal use. However, half-wave rectification directly on the supply mains may be used where the controlled active input power does not exceed 100W or, where the controlled equipment is class II, portable equipment which, in normal use, is only operated for short periods of time and for which the rated power input does not exceed 1200W. NOTE Asymmetrical control means control by a device designed to operate in a different manner on the positive and negative half cycles of an alternating voltage or current Compliance is checked by inspection and by measurement.</p>	<p>The EUT is intended for providing a stand-alone grid. Asymmetrical, abnormal operation causes a disconnection of the unit.</p>	<p>P</p>
<p>3.13</p>	<p>Stability Freestanding equipment intended to be used on a surface such as a floor or a table shall have adequate stability and shall be tested in accordance with Clause 8.14.</p>	<p>The EUT is intended to be fixed (wall mounted).</p>	<p>N/A</p>
<p>3.14</p>	<p>Equipment connected to supply by a plug Equipment intended to be connected to the supply mains by means of a plug shall be constructed so that in normal use there is no risk of electric shock from charged capacitors having a rated capacitance exceeding 0,1 µF, when the pins of the plug are touched. Compliance is checked by the following test. The equipment is supplied at rated voltage. Any switch is then placed in the off position and the equipment is disconnected from the supply mains at the instant of voltage peak. One second after disconnection, the voltage between the pins of the plug is measured with an instrument that does not appreciably affect the value to be measured. The voltage shall not exceed 34 V.</p>	<p>The EUT provides no plug for connection to hazardous voltages. For DC and AC connection wiring terminals are used. No hazardous conductive parts like pins are accessible.</p>	<p>N/A</p>



3.15	Capacitors Capacitors in appliances or accessories likely to be permanently subjected to the supply voltage and used for radio interference suppression or for voltage dividing shall comply with IEC 60384-14. If they have to be tested, they are tested in accordance with Annex G. NOTE Examples of capacitors likely to be permanently subjected to the supply voltage are capacitors incorporated in appliances or accessories which are likely to be operated unattended	Noticed. Refer also to the "List of safety critical components".	P
-------------	--	---	----------

SECTION 4: PROTECTION AGAINST MECHANICAL AND ELECTRICAL FAILURE			
4.1	Prevention of short-circuit and arcing		P
4.1.1	<p>General</p> <p>All terminals, contacts and other live parts shall be so arranged that short-circuit or destructive arcing, either between live parts or between any live part and other conductive material, cannot take place, and that no part other than an easily replaceable contact can be appreciably damaged by an arc or overheating arising from the normal operation of the equipment.</p> <p>Holes for fixing screws shall be so placed that no such short-circuit or arcing can occur when the screws are in position.</p>	Verified. Approved terminals for AC used. Short-circuits or arcing cannot take place.	P
4.1.2	<p>Segregation of internal wiring</p> <p>Where extra-low voltage (see Clause 5.5) and low voltage equipment wiring is within the one enclosure and the extra-low voltage wiring or parts connected thereto are accessible to the standard test finger without the use of tools, either of the following requirements, or a combination thereof, shall apply:</p> <p>(a) The extra-low voltage wiring and associated connections shall be effectively separated from low voltage wiring by means of rigidly fixed screens or barriers or by other effective means such as lacing or enclosure in insulating sleeving.</p> <p>(b) The extra-low voltage wiring and exposed parts shall be insulated for the highest voltage present in any low voltage conductor and shall be so arranged or fixed that, in the event of a conductor breaking away or becoming detached from a terminal, bare extra-low voltage parts cannot come into contact with uninsulated low voltage parts or vice versa.</p> <p>Parts of one voltage system provided with basic insulation shall not come into contact with live parts of other systems.</p> <p>The requirements of Clauses 5.1, 5.2 and 5.3 shall not be applicable to extra-low voltage wiring complying with the requirements of this Clause. Where separate external equipment, operating at extra-low voltage, is supplied from the enclosure in which cables and wiring of different systems are terminated, the extra-low voltage wiring and connections shall be effectively separated from low voltage wiring as in Item (a), unless all parts of external equipment and associated wiring are installed and protected in accordance with the low voltage requirements of the National Wiring Rules.</p>	On relevant positions extra-low voltage wiring is protected by additional tubing or sleeving. Low voltage wiring comply with clauses 5.1, 5.2 and 5.3.	P
4.1.3	<p>Creepage distances and clearances for appliances</p> <p>Creepage distances and clearances for appliances shall be not less than the values in millimetres shown in Table 4.1. The way in which creepage distances and clearances are measured is indicated in Annex C.</p> <p>If a resonance voltage occurs between the point where a winding and a capacitor are connected together, and metal parts separated from live parts by basic insulation only, the creepage distance and clearance shall be not less than the values specified for the value of the voltage imposed by the resonance, these values being increased by 4 mm in the case of reinforced insulation.</p> <p>Compliance is checked by inspection and if necessary by measurement.</p> <p>For appliances provided with an appliance inlet, the</p>	The EUT provides basic insulation between live parts and other metal parts. The EUT provides reinforced insulation between live parts and other user accessible interface parts. See Table 4.1.3.	P

AS/NZS 3100:2009 / Amendment 1: 2010 / Amendment 2: 2012			
Clause	Requirement – Test	Result – Remark	Verdict
	<p>measurements are made with an appropriate connector inserted; for appliances with Type X attachment, they are made with supply conductors of the appropriate current rating, and also without conductors; for other equipment, they are made on the equipment as delivered.</p> <p>For appliances provided with belts, the measurements are made with the belts in place and the devices intended for varying the belt tension adjusted to the most unfavourable position within their range of adjustment, and also with the belts removed.</p> <p>Movable parts are placed in the most unfavourable position; nuts and screws with non-circular heads are assumed to be tightened in the most unfavourable position.</p> <p>The clearances between terminals and accessible metal parts are also measured with the screws or nuts unscrewed as far as possible, but the clearances shall then be not less than 50% of the values shown in Table 4.1.</p> <p>Distances through slots or openings in external parts of insulating material are measured to metal foil in contact with the accessible surface; the foil is pushed into corners and the like by means of the standard test finger shown in Figure 8.10 but it is not pressed into openings.</p> <p>If necessary, a force is applied to any point on bare conductors, other than those of heating elements, on uninsulated capillary tubes of thermostats and similar devices and to the outside of metal enclosures, in an endeavour to reduce the creepage distances and clearances while taking the measurements.</p> <p>The force is applied by means of a test finger having a tip as shown in Figure 8.10 and has a value of (a) for bare conductors and for uninsulated capillary tubes of thermostats and similar devices..... 2 N; and (b) for enclosures.....30 N</p> <p>NOTE 1 If a barrier is interposed and if it is in two parts that are not cemented together, the creepage distance is also measured through the joint.</p> <p>NOTE 2 For appliances having parts with double insulation where there is no metal between basic insulation and supplementary insulation, the measurements are made as though a metal foil were present between the two insulations.</p> <p>NOTE 3 If a barrier is interposed, clearances are measured over the barrier or, if the barrier is in two parts with mating surfaces that are not connected together, through the joint.</p> <p>NOTE 4 When assessing creepage distances and clearances, the effect of insulating linings of metal enclosures or covers is taken into consideration.</p> <p>NOTE 5 Internal conductors are considered to be bare conductors, unless their insulation withstands an electric strength test made between the conductor and metal foil wrapped round the insulation, a test voltage of 2000V being applied for 15 min.</p> <p>NOTE 6 Means provided for fixing the equipment to a support are considered to be accessible.</p> <p>NOTE 7 A component incorporated in an appliance and which may comply with an individual Approval and test specification is to also comply with the creepage distances and clearance specified in this Clause.</p>		
4.1.4	Additional requirements for appliances		P
4.1.4.1	General The requirements in Clauses 4.1.4.2 to 4.1.4.5 are applicable only to appliances.	Considered	P
4.1.4.2	Printed circuit boards	Functional insulation	P

AS/NZS 3100:2009 / Amendment 1: 2010 / Amendment 2: 2012			
Clause	Requirement – Test	Result – Remark	Verdict
	<p>For conductive patterns on printed circuit boards, except at their edges, the values in Table 4.1 between parts of different potential may be reduced as long as the peak value of the voltage stress does not exceed either</p> <p>(a) 150V per millimetre with a minimum distance of 0.2mm, if protected against the deposition of dirt; or</p> <p>(b) 100V per millimetre with a minimum distance of 0.5mm, if not protected against the deposition of dirt.</p> <p>For peak voltages exceeding 50V, the reduced creepage distances apply only if the proof tracking index (PTI) of the printed circuit board is greater than 175 when measured in accordance with Paragraph B4, Annex B.</p> <p>These distances may be reduced further provided that the appliance complies with the requirements of Clause 8.15 when the distances are short-circuited in turn.</p> <p>NOTE When the limits specified above lead to higher values than those of Table 4.1, the values of the table apply.</p> <p>Creepage distances and clearances within optocouplers are not measured.</p> <p>For live parts of different potential separated by basic insulation only, creepage distances and clearances smaller than those specified in Table 4.1 are allowed provided the requirements of Clause 8.15 are met if these creepage distances and clearances are short-circuited in turn.</p>		
4.1.4.3	<p>Distances through insulation</p> <p>The distance through insulation between metal parts for working voltages up to an including 250V shall be not less than 1.0mm if they are separated by supplementary insulation and be not less than 2.0mm if they are separated by reinforced insulation.</p> <p>Compliance is checked by inspection and by measurement.</p> <p>NOTE 1 This does not imply that the distance has to be through solid insulation only. The insulation may consist of solid material plus one or more air layers.</p> <p>NOTE 2 For appliances having parts with double insulation where there is no metal between basic insulation and supplementary insulation, the measurements are made as though there is a metal foil between the two insulations</p> <p>NOTE 3 The specified distances through insulation do not apply to the insulation of internal wiring.</p>	This clause was not applied because the working voltage exceeds the limit of 250V.	N/A
4.1.4.4	<p>Insulation in sheet form</p> <p>The requirement in Clause 4.1.4.3 does not apply if the insulation is applied in thin sheet form, other than mica or similar scaly material, and</p> <p>(a) for supplementary insulation, consists of at least two layers, provided that each of the layers withstands the electric strength test of Clause 8.4 for supplementary insulation; or</p> <p>(b) for reinforced insulation, consists of at least three layers, provided that any two layers together withstand the electric strength test of Clause 8.4 for reinforced insulation.</p> <p>Compliance is checked by inspection.</p>	The EUT provides reinforced insulation between the hazard circuits and extra-low voltage circuits (user accessible interfaces). This insulation is ensured by the use of transformers and optical couplers. The electric strength test was performed according to clause 8.4.	P
4.1.4.5	<p>Supplementary insulation and reinforced insulation</p> <p>The requirement in Clause 4.1.4.3 does not apply if the supplementary insulation or the reinforced insulation is inaccessible and meets one of the following conditions:</p> <p>(a) The maximum temperature rise determined during the tests of Clause 8.15 does not exceed the value specified</p>	The EUT provides reinforced insulation between the hazard circuits and extra-low voltage circuits (user accessible interfaces).	P

AS/NZS 3100:2009 / Amendment 1: 2010 / Amendment 2: 2012			
Clause	Requirement – Test	Result – Remark	Verdict
	<p>in Table 5.7.</p> <p>(b) The insulation, after having been conditioned for 168 h in an oven maintained at a temperature equal to 75°C in excess of the maximum temperature rise determined during the tests of Clause 8.15, withstands the electric strength test of Clause 8.4, this test being made on the insulation both at the temperature occurring in the oven and after cooling to approximately room temperature. Compliance is checked by inspection and by test.</p> <p>For optocouplers the conditioning procedure is carried out at a temperature of 50 °C in excess of the maximum temperature rise measured on the optocoupler during the tests of Clauses 8.12 or 8.15, the optocoupler being operated under the most unfavourable conditions which occur during these tests.</p>	<p>This insulation is ensured by the use of transformers and optical couplers. The electric strength test was performed according to clause 8.4.</p>	
4.2	Mechanical protection of conductors and cables		P
4.2.1	<p>General</p> <p>All conductors and cables shall be of such a type or be so located or protected that mechanical or electrical failure is not likely to occur under the conditions to which they may reasonably be subjected in service.</p>	<p>External cables are not part of the EUT. This shall be considered in the final installation. The internal wires are properly secured. No hazard is expected to occur.</p>	P
4.2.2	<p>Adjacent material</p> <p>All material immediately adjacent to or in contact with a conductor shall be so shaped that it will not cause such abrasion of the conductor or its insulation, braiding or sheathing as could lead to its mechanical or electrical failure.</p>	<p>No mechanical hazard is expected from materials adjacent to the conductors.</p>	P
4.2.3	<p>Passage for conductors</p> <p>Where conductors and cables (including flexible cables and flexible cords) are to be threaded through tubes or channels or passed through openings formed in metal work, the tubes, channels or openings shall be of ample size and, if not bushed, shall have no sharp angles or projecting edges which would be likely to damage a conductor or the insulation, braiding, or sheathing of a cable. Conduit ends and other open ends through which cables pass shall be bushed or so shaped that they will not cause abrasion of conductors or the insulation, braiding, or sheathing of the cables. Where bushes are used, they shall be fixed securely in position.</p>	<p>All parts where conductors are routed through are properly smoothed. No hazard is expected.</p>	P
4.2.4	<p>Protection near moving parts</p> <p>Equipment wiring near moving parts shall be so located or arranged as to guard against the possibility of abrasion of the conductor, or its insulation, braiding or sheathing.</p>	<p>The fan is already approved. Refer also to the list of critical components. The supply wires are so arranged that the possibility of damage is not likely to occur.</p>	P
4.2.5	<p>Unprotected conductors with fibrous insulation</p> <p>Fibrous insulated cables, which are defined as 'unprotected' in AS 3158 shall be used only where they can be installed without damage, will not be subjected to undue bending and abrasion, and are protected from mechanical damage and other deleterious effects by virtue of their location and the general design of the equipment in which they are incorporated.</p>	<p>Such conductors are not provided.</p>	N/A

AS/NZS 3100:2009 / Amendment 1: 2010 / Amendment 2: 2012			
Clause	Requirement – Test	Result – Remark	Verdict
4.3	Terminals and connecting facilities for supply conductors		P
4.3.1	<p>Connecting facilities required</p> <p>All equipment shall be provided with facilities for the connection of supply conductors in one of the following forms</p> <p>(a) Terminals.</p> <p>(b) Contact pins or spring contacts intended to engage with the corresponding contacts of a connector, socket-outlet or cord extension socket. For socket-outlets, the requirements of Clause 3.10 shall apply.</p> <p>(c) Connection of the conductors, flexible cord or flexible cable to internal leads, terminals, lugs or the like, by crimping or other similar suitable devices. This form of connection shall be permitted only in the following cases:</p> <p>(i) Where equipment is connected by a Type Y attachment.</p> <p>(ii) A Type Z attachment, where specifically allowed in an individual Approval and test specification. However, in the absence of an Approval and test specification, a Type Z attachment may be permitted where it is used to provide an essential safety feature and where replacement during the economic life of the equipment is unlikely.</p> <p>(iii) Where equipment has Type Y or Type Z attachments in accordance with Clause 4.5.1 of this Standard.</p> <p>(iv) For equipment not covered by individual Approval and test specifications, where the replacement of the flexible cord or cable by the user of the equipment is not intended or is unlikely having regard to the type of flexible cord and the method of use of the equipment, for example whether it is fixed or portable and the degree to which the supply cable or cord will be subjected to flexure and mechanical damage in service.</p> <p>Twist-on connectors with suitable metal inserts may be used for live conductors but shall not be used for earthing connections.</p> <p>(d) Soldering may be used</p> <p>(i) for Type X attachments in equipment having a rated input not exceeding 250W; and</p> <p>(ii) for Type Y and Type Z attachments;</p> <p>and shall comply with Clause 4.3.5.</p> <p>No portable equipment shall be provided with facilities for the connection of more than one supply flexible cord, unless permitted in an individual Approval and test specification.</p> <p>Any equipment intended for permanent connection to fixed wiring shall be provided with terminals as specified in Item (a).</p>	AC connection: Already approved wiring terminals are provided.	P
4.3.2	<p>Design and construction of terminals</p> <p>All terminals shall be inherently corrosion-resistant or suitably protected against corrosion, and shall be so designed and proportioned that a connection made thereto will not loosen or overheat under normal conditions of use.</p> <p>NOTE For equipment that will be subjected to severe vibration in service, for example a percussion tool, it is generally necessary for special precautions to be taken to ensure that the connections made to the terminals will not slacken off under normal conditions of use.</p> <p>Devices such as self-locking nuts, self-clamping terminals, spring</p>	Already approved wiring terminals are provided. Refer also to "List of safety critical components". The terminals provide an adequate rigidity and clamping for the conductor sizes specified in the installation	P

AS/NZS 3100:2009 / Amendment 1: 2010 / Amendment 2: 2012			
Clause	Requirement – Test	Result – Remark	Verdict
	<p>washers or reusable locking compounds are acceptable for the purpose.</p> <p>All terminals shall be so designed that the conductors connected thereto can be rigidly and effectively clamped between metal surfaces and shall comply with Clause 4.6.1. Connecting plates associated with terminals and forming internal connections shall be in effective electrical contact with the associated terminal in accordance with Clause 4.6.1.</p> <p>Terminals shall be either securely fixed in position within a terminal box or enclosure, or so arranged that movement of the connections is limited by location in a suitable enclosure, recess, housing or the like, provision being made for maintaining adequate clearance between live parts and exposed metal parts. Other arrangements are not precluded, provided that the terminals are suitably restrained.</p> <p>Screws of tunnel-type terminals and other clamping devices, which are intended to clamp directly onto conductors, shall be so shaped and finished that strands of the conductor are not likely to be severed when the screw is tightened to the extent necessary to provide a satisfactory termination. The surfaces against which the terminated conductor is to be clamped shall have no sharp angles or projecting edges that would be likely to damage the conductor and, for tunnel-type terminals, the hole for any pinching screw shall not extend through the conductor-way beneath the clamped conductor.</p> <p>Aluminium conductors shall not be clamped directly by screws in tunnel-type terminals other than special types designed to evenly distribute stress and to break the oxide film on the conductors.</p> <p>Indirect clamping by means of suitable ferrules, plates and the like shall be acceptable, provided that the clamping means breaks the oxide film on the conductors.</p> <p>In general, a self-tapping screw shall not be used as a terminal screw for conductors; the acceptability of self-tapping screws as terminal screws in any particular application will be judged on the circumstances of the case in accordance with Clause 4.8.</p> <p>Die-cast terminal blocks made from zinc-base alloy shall not be used.</p> <p>Terminals provided for direct connection to fixed wiring of an installation shall be so designed and located as to permit the supply cables (other than flexible cables and cables having fewer than seven strands) to be connected in accordance with one of the following methods:</p> <p>(a) Soldered into a cable-socket of appropriate size.</p> <p>(b) Clamped in a terminal or binding post.</p> <p>(c) Terminated in an approved solderless tag or terminating device.</p>	<p>instructions.</p> <p>The terminals are provided inside the enclosure and are fixed in position by mounting on the PCBs. Screws do not clamp the conductors directly.</p>	
4.3.3	<p>Location of terminals</p> <p>The live terminals shall be within a terminal box or an enclosure, and shall be grouped together. The earthing terminal, if any, shall be either within the terminal box or enclosure or on the external surface of the equipment adjacent to the terminal box or enclosure. If the earthing terminal is on the external surface of the equipment, provision shall be made for the earthing conductor of the supply flexible cord or cable to pass through an opening</p>	<p>All terminals for the respective supply and the earthing terminal are directly grouped together inside the enclosure. No parts will get disturbed during connection of the wiring.</p>	P

AS/NZS 3100:2009 / Amendment 1: 2010 / Amendment 2: 2012			
Clause	Requirement – Test	Result – Remark	Verdict
	<p>in the terminal box or enclosure to the earthing terminal. An earthing terminal of the quick-connect type shall not be acceptable on the external surface of the equipment. In equipment, except for those which have Type Y or Type Z attachments in accordance with Clause 4.5.1, the terminal box or enclosure shall be such as will allow access to the terminals and replacement of the flexible cord without dismantling the equipment to such an extent as will disturb the assembly of internal wiring and internal live parts. This does not preclude the terminals of a switch being used as the supply terminals of an equipment, provided that if it is necessary to move the switch for the purpose of connecting the supply flexible cord, the equipment shall incorporate a suitable recess, channel, or space so that the switch and any associated internal wiring will readily return to their correct positions.</p> <p>NOTE See Clause 5.2.2 concerning clearances between terminals and exposed conductive parts.</p>		
4.3.4	<p>Terminal arrangements Except for equipment that is provided with a Type Y or Type Z attachment, the following provisions shall apply: (a) The arrangement of the terminals shall be such as will allow the supply flexible cord or flexible cable to be disconnected and replaced without removing any internal wiring or connections from the terminals. (b) The clamping of the supply conductor at a terminal shall be independent of the clamping of any internal lead at that terminal. This does not apply where the internal lead is effectively anchored to the terminal by means other than the terminal screw or where the replacement of the flexible cord or flexible cable by the user of the equipment is not intended or is unlikely having regard to the type of flexible cord and the method of use of the equipment, for example whether it is fixed or portable and the degree to which the supply cable or cord will be subjected to flexure and mechanical damage in service. (c) Screwless terminals that require special preparation of the conductors shall not be acceptable for the connection of supply flexible cords.</p>	No internal wiring is necessary to be replaced or disconnected during connection to the supply terminals. The clamping for the supply conductors is independent of the clamping of internal conductors.	P
4.3.5	<p>Soldered connections Where facilities for soldered connections are provided, they shall comply with the following requirements: (a) The soldering terminals, lugs or the like shall be so designed that the conductors are held in position independently of the soldering. (b) They shall be so located and arranged as to minimize the likelihood of insulation being bridged by excess solder and so that essential insulation will not be damaged during soldering.</p> <p>NOTE See Clause 4.5.3 and Clause 4.6.</p>	No soldered connections intended for supply conductors present. Wiring terminals are provided.	N/A
4.3.6	<p>Prevention of slipping or spreading of conductors All terminals shall be of a form that will prevent slipping or spreading of conductors or conductor strands; for example, by providing for the clamping of conductors either in a cylindrical hole by means of a suitable binding screw or screws, or between the head of a screw and a base so arranged that it will prevent the conductors from slipping or spreading, or by providing solderless tags or washers or other suitable devices to</p>	Approved terminals are provided.	N/A

AS/NZS 3100:2009 / Amendment 1: 2010 / Amendment 2: 2012			
Clause	Requirement – Test	Result – Remark	Verdict
	<p>prevent such slipping or spreading. Except for equipment with Type Y or Type Z attachments, a device shall not be acceptable as a means of preventing spreading of conductor strands on the terminals of portable equipment, unless it can be readily re-used when connection of the supply flexible cord is renewed.</p> <p>NOTE Terminal washers and lugs having sections such as claws that are intended to fold over and contain strands of a flexible cord or conductor, or a device in which the conductors are held by clinching the shank of a solderless terminal lug, are not deemed to be readily re-usable.</p> <p>The requirement is not applicable to connections made in equipment with Type Y or Type Z attachment.</p>		
4.3.7	<p>Earthing conductors Where the equipment includes an earthing terminal, provision shall be made by means of space within the terminal enclosure, the disposition of the terminals, a separate conductor way, suitable shielding, or other suitable means, to ensure that when correctly wired the connection is made without the earthing conductor of the flexible cord being held or pressed against live terminals or other live parts. In addition, where the equipment is intended to accommodate a supplementary earthing conductor of a supply flexible cord as part of an earth-circuit-monitoring arrangement, provision shall be made for adequate basic insulation of the supplementary earthing conductor.</p> <p>NOTE Earth-monitoring equipment should be supplied with instructions describing how the equipment is to be correctly connected, including reference to the provision of basic insulation for supplementary earthing conductors, and a statement that the connection should be made by a suitably qualified person.</p>	Considered. Adequate wiring terminal exist.	P
4.3.8	<p>Conductors and terminals not to be stressed All conductors shall be so supported and connected that there will be no undue mechanical stress on either the conductors or the terminals to which they are connected.</p>	On the enclosure cable inlets with strain relief are provided which prevents mechanical stress on the terminals.	P
4.3.9	<p>Temperature at terminals The terminals on all equipment shall be so placed, arranged and ventilated that any conductors or cables connected thereto will not be liable to be exposed to temperatures in excess of those permissible for the conductor material and the class of insulation of the conductors or cables, where such insulation is relied upon to prevent short-circuit or contact with material through which leakage may occur.</p> <p>Where temperature conditions are such as will require the use of connecting cables of heat-resisting type, prominent marking shall be provided adjacent to the terminals to indicate the type of connecting cable necessary.</p> <p>For terminals for the connection of supply flexible cords to portable equipment, the temperature rises, in general, shall not exceed 50°C (to allow the connection of flexible cords having maximum operating temperature of 75°C) except under the circumstances covered by Footnote h to Table 5.7, which allows a higher operating temperature.</p>	No excessive temperature is present which could cause a hazard.	P
4.3.10	<p>Access to terminal devices Terminal devices shall not be accessible without the aid of a tool, even if their live parts are not accessible.</p>	To get access to the AC terminals the aid of a tool is required.	P

AS/NZS 3100:2009 / Amendment 1: 2010 / Amendment 2: 2012			
Clause	Requirement – Test	Result – Remark	Verdict
4.4	Flexible cord and connecting plug	Connection is not made via plugs.	N/A
4.4.1	<p>When required</p> <p>Any portable equipment having a rating not exceeding 20A at low voltage shall be provided with a supply flexible cord, except that such flexible cord need not be provided for equipment intended for direct insertion into a socket-outlet, or incorporating a Group 3 appliance inlet, or a Group 2 appliance inlet intended to accommodate a connector with thermal control.</p> <p>The flexible cord shall</p> <p>(a) comply with AS/NZS 3191;</p> <p>(b) unless varied in the individual Approval and test specification, have a length of not less than</p> <p>(i) 0.9m for table top or bench mounted equipment; or</p> <p>(ii) 1.8m for other equipment;</p> <p>which length shall be measured from the body of the equipment at the point where the cord or appliance connector enters the body, irrespective of the length of any cord protector, to the centre of the live pins on the face of the plug.</p> <p>(c) unless varied in the individual Approval and test specification, be not less than</p> <p>(i) if elastomer insulated, ordinary duty sheathed flexible cord; or</p> <p>(ii) if polyvinyl chloride insulated</p> <p>(A) for equipment having a mass not exceeding 3 kg, light duty sheathed flexible cord; or</p> <p>(B) for equipment having a mass exceeding 3 kg, ordinary duty sheathed flexible cord;</p> <p>(d) be of the appropriate current rating;</p> <p>(e) be correctly wired to a plug of appropriate type complying with AS/NZS 3112 or alternatively, for equipment with a rating not exceeding 600 W, with a plug socket adaptor complying with AS/NZS 3122;</p> <p>(f) be correctly connected to a connector of appropriate type if the equipment incorporates an appliance inlet or be correctly connected to terminals of the equipment;</p> <p>(g) incorporate an earthing conductor where the equipment has earthing facilities; and</p> <p>(h) not incorporate an earthing conductor where the equipment is of the double-insulated type.</p> <p>NOTE Item (c) refers to the provision of an 'appropriate' type of flexible cord. The permissible applications of the various types of flexible cord are specified in general terms in the National Wiring Rules. Specific application requirements relating to equipment are specified within the individual Approval and test specifications.</p> <p>Polyvinyl chloride insulated flexible cords shall not be used for equipment having external metal parts, the temperature rise of which exceeds 75 K during the test of Clause 8.12, unless the design of the equipment is such that the power supply cord is not likely to touch such metal parts in normal use.</p> <p>Tinsel flexible cords and flexible cords with conductors having a nominal cross-sectional area of 0.5mm² shall not be used for earthing purposes. Tinsel flexible cord is recognized only for the connection of equipment of small current rating where extreme flexibility is required.</p> <p>For items that have no individual Approval and test specification, the type of flexible cord permitted in</p>		N/A

AS/NZS 3100:2009 / Amendment 1: 2010 / Amendment 2: 2012			
Clause	Requirement – Test	Result – Remark	Verdict
	<p>published individual Approval and test specifications should be used as the basis for evaluating whether a particular type of cord is an appropriate type for the item in question.</p> <p>In the selection of cords, consideration should be given to the following conditions:</p> <p>(i) Physical conditions. (ii) Environment. (iii) Exposure to oils, grease, or solvents. Power supply cords shall have a nominal cross-sectional area not less than those given in Table 4.4.</p>		
4.4.2	<p>Warning notice</p> <p>Any equipment with a current rating above 10A but not exceeding 20A, and which is intended for connection by flexible cord and plug to a socket-outlet, shall have a prominent and durable notice affixed adjacent to the flexible cord entry of the equipment to indicate that it must be connected only to a socket-outlet of appropriate current rating.</p>		N/A
4.5	<p>Supply connection and external flexible cables and cords</p>		P
4.5.1	<p>General</p> <p>Where a supply flexible cord or supply flexible cable is to be connected directly to equipment (that is, not through a connector or the like), the facilities for the connection of the supply flexible cord or cable shall, in addition to complying with Clause 4.3, comply with this Clause.</p> <p>Power supply cords shall be assembled with the equipment by one of the following methods:</p> <p>(a) Type X attachment. (b) Type Y attachment. (c) Type Z attachment.</p> <p>For equipment not covered by an individual Approval and test specification, Type Y or Type Z attachments may be provided in the following circumstances:</p> <p>(i) Where sealing or encapsulation provides an essential safety feature such as waterproofing or avoidance of tampering with adjustments. (ii) In all other cases where the replacement of the flexible cord or flexible cable by the user of the equipment is not intended or is unlikely, having regard to the type of flexible cord and the method of use of the equipment, for example whether it is fixed or portable and the degree to which the supply cable or cord will be subjected to flexure and mechanical damage in service. Riveting, or the use of special screws that are not removable or that are intended to be removed only with the aid of a special single-purpose tool, shall be regarded as an acceptable method of sealing; screws of the conventional straight slot, Phillips head, Allen key type and the like are not acceptable, unless access to their heads is prevented by a plug which is non-removable without irreparable damage.</p>	The power supply cords are not part of the equipment. Therefore this clause was considered as not applicable and must be verified in the final installation.	N/A
4.5.2	<p>Provision for entry of flexible cord</p> <p>The equipment shall include provision for entry of the flexible cord or cable within its protective covering or sheath. The opening through which the flexible cord or cable passes shall be bushed or shaped so as to minimize abrasion of the protective covering and</p>	The cable entries for the conductors in the enclosure are adequately shaped and smoothed so that no hazard regarding abrasion of the insulation	N/A

AS/NZS 3100:2009 / Amendment 1: 2010 / Amendment 2: 2012			
Clause	Requirement – Test	Result – Remark	Verdict
	<p>insulation.</p> <p>A sleeve, guard or other device provided to prevent sharp bending of the supply flexible cord shall not be integral with the cord where a Type X attachment is used, unless it forms part of a specially prepared cord available from the manufacturer or its service agent. It shall be fixed in a reliable manner and not incorporated in the cord anchorage device, unless the anchorage device will clamp the cord effectively with the sleeve removed.</p>	is expected.	
4.5.3	<p>Cord anchorage</p> <p>All equipment intended for connection by means of a flexible cord or flexible cable shall be provided with a saddle, grip, tortuous path or other suitable means so that when the device is connected in the correct manner the stress on the connecting terminals shall be definitely and substantially reduced, and the arrangement shall comply with the test specified in Clause 8.6. For Type X attachment where a tortuous path (labyrinth) is used, it shall be clear how the cord is to be fitted and how the relief from strain and the prevention of twisting are obtained.</p> <p>Where cord anchorage is obtained by means of a screw bearing on the sheathing of a flexible cord, the assembly shall be such that in no way will it damage the flexible cord when correctly applied nor shall it loosen in service. The screw shall</p> <p>(a) be made of suitable insulating material;</p> <p>(b) have a nominal diameter not less than that of the aperture for the flexible cord; and</p> <p>(c) be so shaped as not to damage the flexible cord.</p> <p>The method used for reducing the stress shall be such as will ensure that necessary insulation will not be damaged. The knotting of a flexible cord shall not be deemed an acceptable means of cord anchorage. A floating-type cord anchorage shall not be acceptable unless it is suitably located in position within the terminal compartment, independent of the flexible cord.</p> <p>The cord anchorage shall be capable of accommodating a flexible cord of size and type appropriate* to the equipment that is to be connected. For equipment having an earthing terminal, any cord anchorage designed to embrace the complete flexible cord shall be capable of accommodating a flexible cord that includes an earthing conductor.</p> <p>* See Note to Clause 4.4.1 Item (h).</p> <p>If the effectiveness of the cord anchorage of a connecting device is dependent on the relative location of component parts of the device, the arrangement shall be such as will prevent inadvertent assembly of the component parts in the wrong position.</p> <p>NOTE Wherever possible, a device that provides for anchorage of the complete flexible cord within its braid or sheathing is to be used. Such a device may take the form of a clamp or saddle-type grip. Where it is impracticable to anchor a flexible cord or flexible cable that includes an earthing conductor in this way, the wiring facilities should be such as will permit sufficient slack to be left in the earthing conductor to ensure that any stress is taken up by the live conductors before the earthing conductor becomes taut.</p> <p>Devices such as those in the form of a crimped-on metal ring, which are either not located in position or are incapable of being used more than</p>	Cable entries with strain relief are provided for reducing any stress on the terminals inside the enclosure.	P

AS/NZS 3100:2009 / Amendment 1: 2010 / Amendment 2: 2012			
Clause	Requirement – Test	Result – Remark	Verdict
	once, are not acceptable for equipment with Type X attachments. Floating devices, whether clamps or disks having holes for separate conductors, may be used only where the design of the equipment provides a space in which such devices naturally fit and which locates them in position. They may, however, be accepted without such location where space available is limited and there is little room for them to move; in such a case the device shall not be of metal if there is a possibility of the clamp coming into contact with live terminals. Split devices are acceptable only if they are of such a type that there is no possibility of damage to the flexible cord and they may be removed and replaced without undue difficulty.		
4.5.4	Protection of supply flexible cord Porcelain beads, heat-resistant sleeving, tubing, taping or the like on supply flexible cords shall not be accepted as providing insulation or protection on that flexible cord for equipment with Type X attachment. Beads and similar ceramic insulators on live wires shall be so fixed or supported that they cannot change their position; they shall not rest on sharp edges. The equipment shall include provision for guarding the supply flexible cord against damage from internal moving parts, and internal surfaces having normal operating temperatures in excess of that permissible for the supply flexible cord.	Supply wiring for connection of the external conductors is not part of the equipment. Internal live wiring is sufficiently fixed and all wire ways are smoothed. Wire ways for external conductors are also smoothed. No hot surfaces which could affect the insulation of conductors present.	P
4.5.5	Interconnection cables and cords Facilities for the connection of detachable and non-detachable interconnection flexible cables or cords shall comply with the requirements for the supply cable or cord, except that (a) connectors and appliance inlets used for the interconnection flexible cable or cord shall not be interchangeable with the connectors and appliance inlets used for the power supply cord, if this might impair compliance with this Standard; and (b) the cross-sectional area of the conductors of the interconnection flexible cable or cord is determined on the basis of the maximum current carried by the conductor during the normal operation tests. NOTE 1 An interconnection flexible cable or cord is considered to be a flexible cable or cord provided as part of the complete equipment for purposes other than supply; for example a remote hand-held switching device, an exposed interconnection between two parts of the equipment, or a separate signalling circuit. NOTE 2 Socket-outlets that are not accessible to the user and which are used for the interconnection of various parts of equipment are not considered to be general purpose outlets.	Internal wiring other than for supply purposes is present which is sufficiently fixed and provided with an adequate cross-sectional area for the maximum current. Interchangeability with any supply facility is not possible to occur due to the mechanical construction.	P
4.6	Joints and connections		P
4.6.1	Joints and insulation Where insulation is required on joints or connections in equipment wiring, the thickness need only be equivalent to that required by Clause 5.2.3. All joints and connections, the failure of which could cause a hazard, shall utilize materials and forms of construction that will avoid deterioration or loss of contact pressure in service. Insulating materials which may shrink or deform in service in such a manner as to cause loss of contact pressure at a joint or connection shall not be used unless they are suitably treated or proofed to prevent such shrinkage or deformation, or unless the metallic parts of the joint or connection have sufficient resiliency to compensate for any such shrinkage or deformation and to retain adequate contact pressure in service.	No shrinking of any insulation which is provided in the EUT is expected. All joints and connections are so properly fixed that a loss of contact pressure in service is not expected.	P

AS/NZS 3100:2009 / Amendment 1: 2010 / Amendment 2: 2012			
Clause	Requirement – Test	Result – Remark	Verdict
	<p>Stranded conductors shall not be consolidated by lead-tin soldering where they are subject to contact pressure, unless the clamping means is so designed that there is no risk of bad contact due to cold flow of the solder.</p> <p>NOTE 1 Some thermoplastic materials are regarded as liable to shrink or deform at temperatures normally associated with terminal block applications.</p> <p>NOTE 2 Consolidation of stranded conductors by lead-tin soldering is allowed if spring terminals are used; securing the clamping screws alone is not considered adequate.</p> <p>NOTE 3 Soldering of the tip of a stranded conductor is allowed.</p>		
4.6.2	<p>Soldered joints Soldered joints shall be made without the use of fluxes containing corrosive substances.</p>	Considered.	P
4.6.3	<p>Limitations of soldered joints Soft-soldered joints and soft soldering shall not be used for the connection of conductors or in the construction of any equipment where the temperature of the soldered joint is likely to exceed 120°C in normal operation.</p> <p>NOTE: It is recommended that the soft solder used in electrical work be that listed as 50 Sn in AS 1834.1 and AS 1834.2, this being the grade primarily intended for general electrical purposes.</p>	The temperatures in the whole EUT do not exceed 120°C.	N/A
4.6.4	<p>Joints and connections in lighting fittings No joint or connection shall be made within a lighting fitting except in a space incorporated therein for the purpose.</p>	No lighting fittings provided.	N/A
4.6.5	<p>Solderless joints The attachment of conductors by crimped or similar forms of solderless pressure joints shall be made only with the use of the appropriate attaching tools.</p>	The installation instructions provide information regarding the correct connection.	P
4.6.6	<p>Cascading of adaptors Two-way quick-connect tab and receptacle adaptors and the like shall not be cascaded.</p>	No such connections present.	N/A
4.7	<p>Strength of screw threads and fixings Components that have screw threads, and which will be removed or loosened with the aid of a tool for the purpose of connecting supply conductors to the equipment, together with their fixings, shall be capable of withstanding the test specified in Clause 8.7. Where a number of identical threaded components are involved, tests may be conducted on a representative number at the discretion of the testing laboratory.</p> <p>If one failure occurs and the omission of this component does not prevent the equipment from complying with the remaining requirements of the specification, this shall not in itself constitute non-compliance with this Clause, but all of the remaining represented components shall withstand the test.</p> <p>Where the screwed component or its fixing is of thermoplastic material, the length of engagement of a thermoplastic screw into a tapped hole in metal or in plastic material shall be not less than the nominal diameter of such screw.</p> <p>Testing to the requirements of this Clause shall not be required for equipment with Type Y or Type Z attachments.</p>	To connect external supply conductors to the internal terminals, the enclosure cover has to be removed. The screws of the terminals and the screws to fix the enclosure cover were tested accordingly.	P
4.8	<p>Space-threaded and thread-cutting screws Space-threaded (sheet metal) screws shall not be used for the connection of current-carrying parts, unless they clamp these parts directly in contact with each other and are provided with a suitable means of locking.</p>	Such screws are not provided.	N/A

AS/NZS 3100:2009 / Amendment 1: 2010 / Amendment 2: 2012			
Clause	Requirement – Test	Result – Remark	Verdict
	Thread-cutting (self-tapping) screws shall not be used for the electrical connection of current-carrying parts, unless they generate a full-form standard machine screw thread. Unless the thread is formed by a swaging action such screws shall not, however, be used if they are likely to be removed or replaced during installation or servicing. Thread-cutting and space-threaded screws may be used to provide earthing continuity, provided that it is not necessary to disturb the connection in normal use and that at least two screws are used for each connection.		
4.9	Direct connection to fixed wiring Equipment designed for direct connection to the supply circuit wiring shall comply with the following: (a) Provision shall be made for the entry of insulated conductors within their conduit, sheathing or other protective covering. (b) Terminals suitable for the connection of the supply conductors and an earthing conductor (if required) shall be provided; the terminals shall be fixed in position and shall be grouped together either in a terminal box or within the equipment enclosure, except that the earthing terminal may be located adjacent to the terminal box or enclosure. (c) Where identification is necessary, live terminals shall be marked in accordance with Clause 7.6. (d) Terminals of a heating element or thermostat shall not be used as a means for the connection of supply conductors.	For the connection of external wiring, terminals are provided which are fixed in position and grouped together within the enclosure. Marking of the terminals is adjacent and additionally explained in the installation instructions.	P
4.10	Mechanical strength Equipment shall have adequate mechanical strength and be so constructed as to withstand such rough handling as may be expected in normal use. Compliance is checked by inspection and, if necessary, by the test of Clause 8.8.	The EUT provides a metal enclosure with adequate rigidity. This was also tested regarding clause 8.8.	P
4.11	Degree of protection (IP classification) Where the equipment is marked to classify it as having a specified degree of protection, the equipment shall comply with the appropriate requirements of AS 60529. The tests of AS 60529 shall be carried out after the test of Clause 4.10 if applicable. For equipment assigned with a second characteristic numeral greater than 0, the equipment shall then withstand the tests of Clause 8.4.	The enclosure provides protection class IP54. The test report is enclosed.	P

AS/NZS 3100:2009 / Amendment 1: 2010 / Amendment 2: 2012			
Clause	Requirement – Test	Result – Remark	Verdict
SECTION 5: PROTECTION AGAINST RISK OF ELECTRIC SHOCK			
5.1	<p>Guarding of live parts</p> <p>Except for equipment intended for use only in a position not accessible to unauthorized persons, all equipment shall be so designed and constructed that, when the equipment is standing, supported, or fixed, in a normal manner, no person can inadvertently come into contact with any live part (see also Clause 8.10).</p> <p>If a hole giving access to preset controls is marked as such on the enclosure or reference made to it in the instructions and the setting of this control requires a screwdriver or other tool, the adjustment of the control shall not allow contact with any live parts. A metal test pin having a diameter of 2 mm and a length of 100 mm shall not become live when it is inserted through the hole in every position with a force of 10 N.</p> <p>Covers of equipment, other than accessories, relied upon to prevent inadvertent personal contact with live parts shall be fixed in position in such a manner that a tool is necessary to remove them; wing nuts, knurled nuts and the like are not deemed to comply with this requirement. A slot that will accept a coin is regarded as intended to accommodate a tool for the purpose of this Clause.</p> <p>In addition, the opening or removal of any cover or component, with or without tools, where such opening or removal is necessary as a normal operation of the equipment as distinct from maintenance, repairs, or adjustment, shall not expose live parts to inadvertent personal contact.</p> <p>If a manufacturer instructs the user to remove any covers or components for maintenance, repairs or adjustments, this shall not expose live parts to inadvertent personal contact.</p> <p>Any metal cover or casing enclosing live parts shall be of a strength sufficient to ensure that it cannot be deformed readily so as to come into contact with live parts.</p> <p>Edison-type screw lampholders incorporated in equipment shall be provided with adequate shielding facilities appropriate to the type of lamp with which they may be used.</p>	<p>In normal use no person can come into contact with any live parts. This was verified according to clause 8.10.</p> <p>The enclosure provides IP54. Direct contact to hazardous life parts and/or circuits is not possible to occur. All hazardous conductive parts are proper insulated.</p> <p>A tool is necessary to remove any cover or to open the enclosure.</p> <p>The instruction manual specifies that the user is not permitted to install or open the EUT.</p> <p>The service personal is only permitted to install the EUT in disconnected status.</p> <p>The enclosure provides an adequate rigidity which prevents it from deforming.</p>	P
5.1.1	<p>Class II construction</p> <p>Class II appliances and class II constructions shall be constructed and enclosed so that there is adequate protection against accidental contact with basic insulation and metal parts separated from live parts by basic insulation only.</p> <p>It shall only be possible to touch parts which are separated from live parts by double insulation or reinforced insulation.</p> <p>Compliance is checked by inspection and by applying the test finger of figure 8.10, as described in clause 8.10.</p> <p>NOTE 1 This requirement applies for all positions of the appliance when it is operated as in normal use, even after opening lids and doors and removal of detachable parts.</p> <p>NOTE 2 Built-in appliances and fixed appliances are tested after installation.</p>	The EUT is a class I equipment.	N/A
5.2	Insulation of live parts		P
5.2.1	<p>General</p> <p>Live parts of electrical equipment shall be adequately insulated and supported and shall comply with the</p>	The insulation of live parts provides an adequate protection.	P

AS/NZS 3100:2009 / Amendment 1: 2010 / Amendment 2: 2012			
Clause	Requirement – Test	Result – Remark	Verdict
	<p>following:</p> <p>(a) Clauses 8.3 and 8.4 of this Standard.</p> <p>(b) Any specified requirements for insulation thickness.</p> <p>Unless otherwise specified in a particular clause herein or in an individual Approval and test specification, any specified thickness of insulation shall be regarded as applicable at the thinnest point of the insulation, for example at the bottom of a screwdriver slot in a brush holder cap.</p>	<p>Measurements according to clause 8.3 and 8.4 were performed and the insulation thickness is ensued by use of sufficiently dimensioned components. Refer also to “list of safety critical components”.</p>	
5.2.2	<p>Separation of live parts from non-current-carrying conductive parts</p> <p>The support and insulation of every live part shall be such as will ensure that no live part can make contact with any non-current-carrying conductive part exposed to personal contact.</p> <p>In respect of terminals of components such as switches, adequate clearances shall be maintained or insulation shall be provided to prevent contact of the terminals, or loose strands of flexible cords intended to be terminated therein, with exposed conductive parts. Where necessary, provision shall be made to ensure that conductors protruding through terminals, when normally connected, will not contact exposed conductive parts.</p>	<p>The live parts and circuits are sufficiently insulated and separated from non-current-carrying conductive parts and/or circuits.</p>	P
5.2.3	<p>Equipment wiring</p> <p>NOTE This Clause deals only with requirements for electrical insulation. In some instances further mechanical protection of equipment wiring may be necessary such as by providing a braiding, covering, sheathing or sleeving, or by location of the wiring in order to comply with Clauses 3.1, 3.2 and 4.2.</p>	<p>Considered.</p>	P
5.2.3.1	<p>General requirements</p> <p>Where equipment wiring is insulated in order to comply with Clauses 5.1, 5.2.1 and 5.2.2, such insulation shall be of a grade appropriate to the voltage to which it will be subjected in ordinary use. Insulants covered by this Standard shall comply with</p> <p>(a) the thickness requirements of Clauses 5.2.3.2 or 5.2.3.3; or</p> <p>(b) the thickness requirements of AS/NZS 3191.</p> <p>However, for other insulation the suitability of the insulant is assessed and an electric strength test shall be made between the conductor and metal foil wrapped around the insulation, a test voltage of 2000V being applied for 15 min.</p> <p>NOTE Where the insulant is adequately specified and compliance with this test is obvious, the test need not be conducted.</p> <p>Where equipment incorporates a component, such as a pilot lamp, which is connected to the supply terminals of the equipment but operates at a lower voltage than at those terminals, the wiring to such component shall have a grade of insulation appropriate to the rated voltage of the equipment. If, however, the reduced voltage is obtained from the potential drop across a shunt (other than a section of an element or winding) and if the conductors are separated from exposed metal parts by adequate spacing or by effective insulating means appropriate to the rated voltage of the equipment, then the insulation between the conductors need only be appropriate for the voltage of the component.</p> <p>Where the equipment wiring is in the form of a cable it shall comply with the relevant Approval and test</p>	<p>The insulation thickness of wiring carrying live parts is sufficient. Refer also to clause 5.2.1.</p>	P

AS/NZS 3100:2009 / Amendment 1: 2010 / Amendment 2: 2012			
Clause	Requirement – Test	Result – Remark	Verdict
	specification except as provided in Clauses 5.2.3.2 and 5.2.3.3.		
5.2.3.2	<p>Specific requirements – PVC insulation Specific requirements for wiring with PVC insulation are as follows:</p> <p>(a) For internal equipment wiring and accessible equipment wiring not subject to flexing or damage, the following shall apply:</p> <p>(i) <i>General</i> Insulation of internal equipment wiring of 250 V grade shall have an average aggregate thickness between any two live conductors and between any live conductor and exposed metal of not less than 0.5mm, and in no case shall the minimum aggregate thickness at any point be less than 0.35mm. Where insulating sleeving is used, it shall be a close fit over the conductor or other sleeving or otherwise shall be securely fixed in position.</p> <p>(ii) <i>Maximum operating temperature</i> Flexible cords with V60, V75 and V90 insulants may have a maximum operating temperature of 80°C, 95°C and 100°C, respectively, when used as internal equipment wiring in such a manner as to be not subjected to flexing.</p> <p>(b) For accessible equipment wiring subject to flexing or damage, or external equipment wiring of 250V grade, insulation shall have an average aggregate thickness of not less than 0.8mm, and the minimum thickness at any point shall be not less than 0.6mm except as otherwise provided for a specific type of cable in the appropriate Approval and test specification, for example, parallel 2 core unsheathed.</p>	Refer to clause 5.2.3.1.	N/A
5.2.3.3	<p>Specific requirements – fibrous insulation The thickness of 250V grade fibrous insulation for internal, accessible and external equipment wiring shall comply with AS 3158 or AS/NZS 3191, as appropriate. Fibrous insulation used for accessible or external equipment wiring shall be so treated or covered as to render it impervious to moisture; a cable complying with AS 3158 shall be regarded as satisfactory in this respect.</p>	No such insulation is provided.	N/A
5.2.4	<p>Arrangement of equipment wiring Precautions shall be taken in the support and fixing of equipment wiring to ensure that live parts, including any one conductor that may become detached from its termination, cannot become exposed to personal contact by protruding through an opening without coming into contact with exposed metal. In the determination of compliance with this requirement, the dimensions and disposition of the opening shall be taken into consideration.</p> <p>Attachment of one conductor to another by tying, lacing, clipping, or the like, is regarded as a satisfactory means of fixing and support, provided that any one conductor detached from its termination is so retained in position as to comply with this Clause.</p>	All internal wires are reliable fixed. Additionally the enclosure provides no opening through which the wiring could protrude.	P
5.3	Earthing facilities		P
5.3.1	<p>Exposed metal parts to have means of earthing If equipment includes any exposed metal parts, then all such exposed metal parts shall be in good electrical contact with each other, and the equipment shall be provided with a common earthing facility by means of</p>	A main protective earthing terminal is provided as a wiring terminal mounted on a PCB within the enclosure.	P

AS/NZS 3100:2009 / Amendment 1: 2010 / Amendment 2: 2012			
Clause	Requirement – Test	Result – Remark	Verdict
	<p>which all the exposed metal parts may be effectively earthed.</p> <p>For combination gas-electric equipment, the main metallic gas pipe of the equipment to which the incoming gas supply is to be directly connected shall be bonded to the earthing terminal of the equipment.</p> <p>Metal parts that are coated with porcelain enamel, paint or similar insulating finishes, shall not be deemed to have been brought into good electrical contact with other parts merely by contact with the coated surface or by screws or bolts passing through those portions of the parts that are coated.</p> <p>The coating of metal parts with porcelain enamel is not acceptable alone as justification of absence of earthing of such parts.</p> <p>Flexible metallic conduit or tubing enclosing the conductors between movable component parts of an equipment shall not be relied upon for earthing purposes.</p>	All accessible conductive parts are reliably bonded to protective earth.	
5.3.2	<p>Method of making the earth connection</p> <p>Facilities for earthing shall take one of the following forms:</p> <p>(a) A terminal suitable for the attachment of an earthing conductor.</p> <p>(b) The earthing contact of an appliance inlet.</p> <p>(c) Other approved means.</p> <p>A constructional bolt, stud, or screw may be used as the earthing terminal on equipment having exposed metal parts only if all the following conditions are observed:</p> <p>(i) The earthing conductor can be removed from the terminal without in any way reducing the effectiveness of the bolt, stud or screw as a constructional medium, or causing any parts of the equipment to lose their relative rigidity.</p> <p>NOTE This provision does not preclude the use, as an earthing terminal, of a stud which also serves for securing a terminal cover provided that it complies with Items (ii) and (iii).</p> <p>(ii) The removal of any covers, or parts of which are likely to be removed in obtaining access to terminals or in adjusting the equipment or parts thereof, shall not disturb or reduce the effectiveness of the earthing connection.</p> <p>(iii) The bolt, stud or screw is not used for fixing the equipment in position or for adjusting the position of the equipment or any part of it.</p>	A main protective earthing terminal is provided as a wiring terminal mounted on a PCB within the enclosure which distributes the protective bonding. The removal of the cover for connection purposes do not disturb or reduce the effectiveness of the earthing connection.	P
5.3.3	<p>Design and construction of earthing terminal</p> <p>The earthing terminal provided on any equipment shall be capable of accommodating an appropriate internal earthing conductor and a supply earthing conductor of the size required by the National Wiring Rules.</p> <p>The current-carrying capacity of any earthing terminal shall be not less than that of the earthing conductors to be connected.</p>	Considered.	P
5.3.4	<p>Resistance of earthing connection</p> <p>The resistance between the earthing facility and any exposed metal parts shall not exceed 1Ω for readily accessible exposed metal parts that rotate, reciprocate or oscillate continuously, and 0.1Ω in all other cases, when tested in accordance with Clause 8.4.</p>	Measurements were performed. See appended table.	P
5.3.5	<p>Printed conductors</p> <p>The printed conductors of printed circuit boards shall not be used to provide earthing continuity in hand-held</p>	PCB traces are used for distributing the protective bonding (from main	P

AS/NZS 3100:2009 / Amendment 1: 2010 / Amendment 2: 2012			
Clause	Requirement – Test	Result – Remark	Verdict
	equipment. They may be used to provide earthing continuity in other equipment if at least two tracks are used with independent soldering points and the equipment complies with the requirement of Clause 8.4 for each circuit.	protective earthing terminal to enclosure and other parts which are required to be earthed) within the EUT. At least two soldering points are used for connection. The EUT was tested against clause 8.4.	
5.4	Equipment with double insulation	The EUT is a class I equipment.	N/A
5.4.1	<p>General Equipment may be accepted as having double insulation only if it complies with Clause 5.4 and is capable of passing the tests prescribed herein. NOTE 1 See Annex D for information on the design of electrical equipment having double insulation. NOTE 2 Sheathed-type flexible cords that comply with AS/NZS 3191 are regarded as affording double insulation between conductors and any metal in contact with the sheathing. In addition, the following forms of construction are considered as acceptable: (a) Equipment having metal parts that can be touched and that are separated from live parts by insulation that is considered to be the equivalent of double insulation. NOTE 3 An example of this form of construction is the use of optocouplers. (b) Equipment having metal parts that can be touched, and which are intentionally connected to live parts through an impedance which is designed to preserve the appropriate level of safety. Parts connected by protective impedances shall be separated by double insulation or reinforced insulation.</p>		N/A
5.4.2	<p>Supplementary insulation Supplementary insulation shall consist of suitable non-hygroscopic insulating materials possessing adequate mechanical strength, and shall comply with the test requirements specified in Clause 8.4.3. Any supplementary insulation in the form of coverings, linings and the like shall be securely fixed in position and shall be such as it will maintain its position and insulating properties under any conditions of normal wear and tear, or other deteriorating factors that can be reasonably expected in service. The arrangements of the supplementary insulation shall be such that in the event of failure of the basic insulation due to a fault condition, the effectiveness of the supplementary insulation shall not be impaired.</p>		N/A
5.4.3	<p>Basic insulation Basic insulation shall consist of suitable material possessing adequate mechanical strength and shall comply with the test requirements specified in Clause 8.4.3.</p>		N/A
5.4.4	<p>Reinforced insulation Instead of double insulation, the use, in equipment, of a single layer of insulation may be accepted as affording equivalent protection under the following conditions: (a) The single layer of reinforced insulation shall be of non-hygroscopic insulating material possessing adequate mechanical strength.</p>		N/A

AS/NZS 3100:2009 / Amendment 1: 2010 / Amendment 2: 2012			
Clause	Requirement – Test	Result – Remark	Verdict
	<p>(b) The insulation shall be suitable for the particular application involved and shall not give rise to danger, either</p> <p>(i) through the functioning of the equipment under conditions required by its use at rated loading; or</p> <p>(ii) through the mechanical or electrical failure of the equipment, or of any part thereof.</p> <p>(c) Precautions shall be taken to guard against the accidental bridging of the insulation by metal or partially conducting material such as carbon dust or moisture, which can be reasonably anticipated to accumulate under normal conditions of use.</p> <p>(d) The insulation shall comply with the test requirements specified in Clause 8.4.3.</p>		
5.4.5	<p>External metal parts The equipment shall have no external metal other than the parts listed in Items (b) to (d) of Clause 2.1.23 (the definition for exposed metal.)</p>		N/A
5.4.6	<p>Detachable covers The removal of any covers that are detachable without the use of tools shall not expose to personal contact</p> <p>(a) live parts;</p> <p>(b) metal parts separated from live parts by basic insulation; or</p> <p>(c) the surface of basic insulation. Exposure of such parts due to the removal of a lamp from a lampholder shall not be a cause for rejection in terms of this requirement. Accessible or external equipment wiring that complies with Clause 5.2.3.2 (b) is deemed to comply with this Clause.</p>		N/A
5.4.7	<p>Arrangement of equipment wiring Precautions shall be taken in the support and fixing of equipment wiring to ensure compliance with the following requirements:</p> <p>(a) Live parts, including any one conductor that may become detached from its termination, cannot come into contact with either supplementary insulation or external metal parts or become exposed to personal contact by protruding through an opening.</p> <p>(b) Basic insulation cannot come into contact with external metal parts.</p> <p>(c) Basic insulation cannot become exposed to personal contact by protruding through an opening. Attachment of one conductor to another by tying, lacing, clipping, or the like, is regarded as a satisfactory means of fixing and support, provided that any one conductor detached, from its termination is thus so retained in position as to comply with this Clause. Where a single layer of reinforced insulation is accepted as the equivalent of double insulation in accordance with Clause 5.4.4, a live part in contact with the reinforced insulation is not precluded by the above requirements.</p>		N/A
5.4.8	<p>Insulation of internal wiring The average aggregate thickness of basic insulation between any two live conductors and between any live conductor and supplementary insulation shall be not less than 0.5mm.</p>		N/A

AS/NZS 3100:2009 / Amendment 1: 2010 / Amendment 2: 2012			
Clause	Requirement – Test	Result – Remark	Verdict
	<p>The average aggregate thickness of supplementary insulation shall be not less than 0.6mm.</p> <p>The aggregate thickness of insulation at any point shall be not less than 0.35 mm and 0.44mm for basic and supplementary insulation respectively.</p> <p>A regulatory authority may, however, accept a lesser aggregate thickness of certain types of insulation where satisfied that the insulation is superior to those that are generally used for similar applications and has the requisite mechanical and electrical strength.</p> <p>Where insulating sleeving is used, it shall be a close fit over the conductor or other sleeving, or otherwise shall be securely fixed in position.</p> <p>Notwithstanding the requirements of this Clause, insulation thickness complying with AS/NZS 3191 is deemed to be satisfactory.</p> <p>For appliances, the requirements of Clause 4.1.4.3 are not applicable to the insulation of internal wiring complying with AS/NZS 3191.</p>		
5.4.9	<p>Openings in external metal walls</p> <p>Where a flexible cord or other conductor passes through an external metal wall, a substantial insulating bush shall be securely fixed in the opening and shall comply with the test requirements specified in Clause 8.4.3 for supplementary insulation.</p>		N/A
5.4.10	<p>Radio interference suppression devices</p> <p>No radio interference suppression device shall be connected between live parts and external metal parts of double-insulated equipment. Any radio interference suppression capacitor connected between live parts and internal metal parts (for example, in parallel with the basic insulation) shall have a capacitance not exceeding 0.05µF.</p>		N/A
5.5	<p>Extra-low voltage equipment</p> <p>Clauses 5.1, 5.2 and 5.3 shall not apply to equipment rated at extra-low voltage, except that DC equipment rated above 50V shall be capable of withstanding the high voltage test specified in Clause 8.4. If extra-low voltage wiring or parts connected thereto are accessible to the standard test finger without the use of tools, they shall be connected to a safety extra-low voltage supply.</p>	The EUT is intended to be supplied by voltages above the limits of extra-low voltage. Nevertheless extra-low voltage circuits are provided within the EUT which are separated from low voltage circuits by reinforced insulation. These circuits were considered to be accessible.	P
5.6	<p>Switches in portable heating appliances</p> <p>For portable heating appliances, any switch controlling an element that is accessible to personal contact (see Clause 8.10) shall open all live conductors connected to the element; however, a single-pole switch may be used under the following conditions:</p> <p>(a) If it controls only a portion of the element, the remaining portion of which is not controlled by any switch on the appliance and is open to view and is luminous when energized.</p> <p>(b) If it controls only a portion of the element, the whole of which is under the control of a switch opening all live conductors connected thereto and if the portion not controlled by the single-pole switch is open to view and is</p>	The EUT is no portable heating appliance.	N/A

AS/NZS 3100:2009 / Amendment 1: 2010 / Amendment 2: 2012			
Clause	Requirement – Test	Result – Remark	Verdict
	luminous when energized.		
5.7	<p>Temperature rises for components and insulating material</p> <p>The temperature rises of components and of electrical insulating materials used in the construction of electrical equipment shall not exceed the values specified in Table 5.7 when tested in accordance with Clause 8.12. The reference ambient temperature shall be as specified in Clause 8.1.</p>	See appended table.	P
5.8	<p>Fault-indicating devices</p> <p>Any device, other than a circuit-interrupting device, intended to indicate to the user that a fault exists in equipment, shall be so designed and constructed that a defect in the fault-indicating device itself shall not give rise to a false indication.</p> <p>NOTE Defect in this context is intended to mean any fault or failure such as failure of a lamp or other component, which may reasonably be anticipated in service (see Clause 3.1).</p> <p>Any such device intended to indicate that a dangerous potential exists on any external metal parts of equipment shall indicate when the potential difference between such external metal parts and earth (or other reference point where an isolated system is used) reaches a predetermined voltage which shall not exceed 32Vr.m.s. Any external metal parts of such devices that are connected to internal wiring shall be so arranged that under no circumstances can they reach a potential exceeding 32Vr.m.s, or shall be so arranged that under no circumstances can a leakage current in excess of 2mA flow when the external metal part is connected directly to earth (or other reference point where an isolated system is used) through a conductor having a negligible impedance.</p>	No device which may lead to misunderstanding in case of fault present.	N/A
5.9	<p>Fixing of handles, knobs, or the like</p> <p>Handles, knobs, grips, levers, or the like, shall be fixed in a reliable manner so that they will not work loose in normal use if loosening might result in a hazard.</p> <p>If handles, knobs, or the like, are used to indicate the position of switches or similar components, it shall not be possible to fix them in a wrong position if this might result in a hazard.</p> <p>Compliance is checked by inspection, by manual test and by trying to remove the handle, knob, grip or lever by applying for 1min. an axial force of a value as follows:</p> <p>(a) If the shape of these parts is such that an axial pull is unlikely to be applied in normal use, the force is</p> <p>(i) 15 N for actuating members of electrical components; and</p> <p>(ii) 20 N in other cases.</p> <p>(b) If the shape is such that an axial pull is likely to be applied, the force is</p> <p>(i) 30 N for actuating members of electrical components; and</p> <p>(ii) 50 N in other cases.</p> <p>NOTE Sealing compounds and the like, other than self-hardening resins, are not considered to be adequate to prevent loosening.</p>	No handles or knobs provided.	N/A

AS/NZS 3100:2009 / Amendment 1: 2010 / Amendment 2: 2012			
Clause	Requirement – Test	Result – Remark	Verdict
SECTION 6: RESISTANCE TO HEAT, FIRE AND TRACKING			
6.1	<p>General</p> <p>This Section applies only to equipment designated 'attended' or 'unattended' in a particular Approval and test specification.</p> <p>For particular Approval and test specifications that do not designate equipment as 'attended' or 'unattended' the requirements of Annex A apply.</p>	Considered.	P
6.2	<p>Resistance to heat</p> <p>External parts of non-metallic material, parts of insulating material supporting live parts including connections, and parts of thermoplastic material providing supplementary or reinforced insulation, the deterioration of which might cause the equipment to fail to comply with this Standard, shall be sufficiently resistant to heat.</p> <p>Compliance is checked, if required, by Footnote^e to Table 5.7 and by Footnote[†] to Table 8.15.9, using the test of Paragraph B2, Annex B.</p>	Tests according to Annex B were performed. See appended table.	P
6.3	<p>Resistance to fire</p> <p>Parts of non-metallic material shall be resistant to ignition and spread of fire.</p> <p>Compliance is checked by the tests of Paragraph B3, Annex B.</p> <p>This requirement does not apply to decorative trims, knobs, wiring insulation and other parts not likely to be ignited or to propagate flames originating from inside the equipment.</p> <p>Alternatively, compliance may be checked as specified in Clause 30.2 of AS/NZS 60335.1.</p>	Tests according to Annex B were performed. See appended table.	P
6.4	<p>Resistance to tracking</p> <p>Insulating material across which a tracking path may occur shall have adequate resistance to tracking, taking into account the severity of its duty conditions.</p> <p>Compliance is checked by the tests of Paragraph B4, Annex B.</p>	The PCBs are already approved.	N/A

AS/NZS 3100:2009 / Amendment 1: 2010 / Amendment 2: 2012			
Clause	Requirement – Test	Result – Remark	Verdict
SECTION 7: MARKING			
7.1	<p>Information to be marked</p> <p>All equipment shall be marked with the following information:</p> <p>(a) The name or registered trade name or mark of the manufacturer or of the responsible vendor.</p> <p>NOTE In every state and territory of Australia and in New Zealand legislation has been enacted which requires that electrical equipment of a declared class or type should not be marketed unless approved by the relevant regulatory authority. It may be essential in terms of the legislation that certain classes or types of article be marked with the approvals marking allotted by the relevant authority.</p> <p>(b) The operating voltage and the rating in amperes or loading in watts or volt-amperes. For equipment other than class III equipment, that is intended for connection to the supply mains the marking of the operating voltage for single phase equipment shall be at least 230V and for polyphase equipment at least 400V or a rated voltage range that includes 230V for single phase equipment and 400V for polyphase equipment.</p> <p>(c) Where the use of equipment is limited either by its own nature or by the nature of any component to a particular system, it shall be marked with those details of the system (such as DC, AC, phases, frequency) to which the use of the equipment or any component thereof is limited.</p> <p>(d) Where a manufacturer or responsible vendor markets a number of different types of the same article, each article shall be marked with the catalogue number, type number or name, or other marking that will distinguish it from any other type of the same article.</p> <p>(e) If applicable, designation for degree of protection against moisture including any pressure, head or time.</p> <p>NOTE Information on degrees of protection is contained in AS 60529.</p> <p>(f) If compliance with this Standard depends upon the operation of a replaceable thermal link or fuse link, the reference number or other means for identifying the link shall be marked at a place so that it is clearly visible when the appliance has been dismantled to the extent necessary for replacing the link.</p> <p>NOTE Marking on the link is allowed as long as the marking is legible after the link has failed.</p> <p>This requirement does not apply to links that can only be replaced together with a part of the appliance.</p> <p>Where abbreviations or symbols are used in lieu of the appropriate wording, the following shall apply; however, other abbreviations that clearly convey the intention may be accepted:</p> <p>The numerical value of the frequency and the number of phases may be coupled with the alternating current abbreviation or symbol.</p> <p>Notwithstanding the requirements of an individual Approval and test specification, the following requirements shall apply:</p> <p>(i) The above marking, viz: 'alternating current' or 'a.c. or '~' shall be acceptable for designating equipment intended for operation on a.c. only. In addition, the presence of a marking that indicates the frequency of the supply voltage shall render the marking 'alternating current' or 'a.c. or '~' unnecessary.</p>	<p>Considered.</p> <p>The type label contains the relevant information.</p>	P

AS/NZS 3100:2009 / Amendment 1: 2010 / Amendment 2: 2012			
Clause	Requirement – Test	Result – Remark	Verdict
	(ii) Any marking required shall be expressed in SI units, unless otherwise specified in an individual Approval and test specification.		
7.2	<p>Method of marking</p> <p>Unless provision for a special form of marking is made in an individual specification, marking required under Items (a), (b), (c), (d), (e) and (f) of Clause 7.1 shall be legible and except where permissible under Paragraph four below, indelible, and shall be made either on the equipment itself or on a nameplate securely fixed thereto. Adhesive metallic labels shall not be fixed in locations where, if they become detached, they may readily touch live parts or bridge insulation.</p> <p>Nameplates incorporating a durable surface finish, including those with particulars printed photographically in conjunction with anodizing, shall be regarded as indelible.</p> <p>Where marking is by adhesive non-metallic labels, surface transfers, painting, silk-screening, printing with etching dyes or similar means, the marking shall be sufficiently durable for its purpose and located where it will not be subjected to conditions that may lead to its deterioration, having regard to the quality of marking, the surface to which it is applied, and service conditions such as temperature, moisture, abrasion and handling.</p> <p>The marking of fixed equipment shall be clearly discernible from the outside after the equipment has been fixed as in normal use, but, if necessary, after removal of a cover.</p> <p>The marking of other equipment shall be clearly discernible from the outside, if necessary, after removal of a cover; for portable equipment, the removal of this cover shall not require the use of a tool.</p> <p>Indications for switches, thermostats, thermal cut-outs and other control devices shall be placed in the vicinity of these components; they shall not be placed on removable parts if these parts can be replaced in such a way that the marking is misleading.</p>	<p>The type label is legible proper visible and do not cause misleading.</p> <p>The type label is made of a self-adhesive non-metallic material. The durability was tested.</p> <p>See appended table.</p>	P
7.3	<p>Double marking</p> <p>If any equipment is to be marked with its load in watts and is marked with more than one voltage but only one wattage, then the marked wattage shall correspond to the wattage measured at the highest marked voltage.</p>	Wattage is marked.	P
7.4	<p>Marking of earth connections</p> <p>The provisions of this Clause shall apply to all equipment except that which has a Type Z attachment.</p> <p>The earthing terminal of any equipment shall be identified by means of the word 'earth' or the letter 'E' or the international earth symbol, viz. ⊕, or any combination thereof, marked in a legible and indelible manner on or adjacent to the terminal; however, for equipment arranged only for direct connection to fixed wiring of an installation</p> <p>(a) the earthing terminal need not be marked if its function is clearly evident, for example where the earthing terminal stud or screw is obviously attached to a metal frame or enclosure; or</p> <p>(b) if the earthing terminal is within a terminal box or enclosure, any marking which is required may be</p>	The earthing terminal is marked with the letters PE (protective earth).	P

AS/NZS 3100:2009 / Amendment 1: 2010 / Amendment 2: 2012			
Clause	Requirement – Test	Result – Remark	Verdict
	<p>effected in a durable manner by means such as painting or a suitable transfer.</p> <p>Lettering used for the marking of the earthing terminal shall be of such a size, or so indented or embossed, as to be conspicuous.</p> <p>The marking required by this Clause may be supplemented by other identifying features, such as plating or green colouring of earth connections, or the word 'green'. In any equipment the marking required by this Clause shall not be used to identify anything other than an earthing terminal or facility.</p>		
7.5	<p>Marking of class II equipment</p> <p>All Class II equipment, other than accessories, shall be identified by means of the international symbol for double-insulated equipment, viz. , or the words 'DOUBLE INSULATED'.</p> <p>Such markings shall be legible and indelible and shall be made either on the equipment itself or on a nameplate securely fixed thereto.</p> <p>The dimensions of the symbol for Class II construction shall be such that the length of the sides of the outer square is about twice the length of the sides of the inner square. The length of the sides of the outer square shall be not less than 5mm, unless the largest dimension of the appliance does not exceed 150mm, in which case the dimensions of the symbol may be reduced, but the length of the sides of the outer square shall be not less than 3mm.</p> <p>The symbol for Class II construction shall be so placed that it will be obvious that it is a part of the technical information and is unlikely to be confused with any other marking.</p>	The EUT is a class I equipment.	N/A
7.6	<p>Marking of live supply connections</p> <p>Where it is necessary to mark and identify live supply connections, the following system shall be used unless otherwise specified in an individual Approval and test specification:</p> <p>(a) For active connections, any marking or abbreviation which clearly indicates the intent.</p> <p>(b) For neutral connections, N (or Neutral).</p> <p>In any equipment, marking as above shall not be used other than to indicate live connections.</p>	AC live terminals are clearly marked with the L and N.	P
7.7	<p>Additional marking of multi-rated equipment</p> <p>Where an equipment is provided with facilities for supply by flexible cord and plug and is designed for conversion to a rating which exceeds that at which the equipment is initially intended to operate, the equipment shall be marked with the following information:</p> <p>(a) Instructions which clearly indicate how the equipment is to be converted to any higher rating.</p> <p>(b) Details for fitting the correct type of supply flexible cord and plug and the appropriate socket-outlet to be used for each rating which exceeds 10A.</p> <p>Such marking shall be legible and indelible, and shall be made either on the equipment itself or on a nameplate securely fixed thereto.</p>	This clause does not apply.	N/A
7.8	<p>Equipment with type X, type Y and type Z attachments</p> <p>The instructions shall contain the substance of the</p>	No type x, y, z attachments provided with the EUT.	N/A

AS/NZS 3100:2009 / Amendment 1: 2010 / Amendment 2: 2012			
Clause	Requirement – Test	Result – Remark	Verdict
	<p>following:</p> <p>(a) For equipment with Type X attachment having a specially prepared cord, if the supply cord is damaged, it shall be replaced by a special cord or assembly available from the manufacturer or its service agent.</p> <p>(b) For equipment with Type Y attachment, if the supply cord is damaged, it shall be replaced by the manufacturer or its service agent or similarly qualified person in order to avoid a hazard.</p> <p>(c) For equipment with Type Z attachment, the supply cord cannot be replaced. If the cord is damaged the equipment should be scrapped.</p>		
7.9	<p>Legibility of marking</p> <p>The marking required by Section 7 shall comply with Clause 8.13.</p>	Test was performed. See appended table.	P
7.10	<p>Instructions for installation and use</p> <p>If it is necessary to take special precautions when installing or using equipment, details shall be given in an instruction sheet, which shall accompany the equipment.</p>	<p>The installation instructions state the relevant details which are necessary for installation, handling and use.</p> <p>The document will accompany the product by shipment.</p>	P

AS/NZS 3100:2009 / Amendment 1: 2010 / Amendment 2: 2012			
Clause	Requirement – Test	Result – Remark	Verdict
SECTION 8: TESTS			
8.1	<p>General</p> <p>In general, the tests specified in this Section shall be carried out on equipment as received.</p> <p>A test of this Standard, or any individual Approval and test specification, that is not appropriate to any particular equipment because of the method of its construction or the technology of its design shall not be conducted. In such cases, a regulatory authority may substitute tests, which it considers to be appropriate.</p> <p>In any equipment a component that is not depended upon for safety*, and the failure or malfunction of which would not introduce a hazard, need not be tested for compliance with any relevant Approval and test specification.</p> <p>* For example, an air-break switch which is not intended as the principal means of opening the supply to the equipment or an independent portion thereof.</p> <p>Where equipment is marked with a rated voltage of 230V a.c. or a voltage range that includes 230V a.c. for single phase equipment, the rated voltage is equal to 240V a.c. in Australia and 230V a.c. in New Zealand or the highest marked voltage which ever is greater.</p> <p>Where equipment is marked with a rated voltage of 400 V a.c or a voltage range that includes 400V a.c. for polyphase equipment, the rated voltage is equal to 415V a.c. in Australia and 400V a.c. in New Zealand or the highest marked voltage which ever is greater.</p> <p>In all other cases, such tests shall be carried out at the highest marked voltage.</p> <p>In Australia, for equipment other than class III equipment, that is intended for connection to the supply mains and that is not marked with an operating voltage of at least 240V for singlephase equipment and at least 415V for three-phase equipment, for testing purposes the rating in amperes or loading in watts or volt-amperes is equal to:</p> <p>a) the rated value, for accessories where the rating has been determined for operation at 240 V for single-phase equipment and 415 V for three-phase equipment, as appropriate.</p> <p>b) the calculated value corresponding to 240 V for single-phase equipment and 415 V for three-phase equipment, as appropriate, in all other cases.</p> <p>NOTE 1 Example of calculation</p> <p>If the equipment is marked with an operating voltage of 230V and a current rating in amperes "A" or a loading in watts "P" or a loading in volt-amperes "VA", it will be tested as if it is marked with an operating voltage of 240V and a current rating in amperes of "A x (240/230)" or a loading in watts of "P x (240/230)²" or a loading in volt-amperes of "VA x (240/230)²".</p> <p>The frequency of the test (supply) voltage shall be 50Hz, unless the equipment is intended for operation at some other particular frequency.</p> <p>If any equipment incorporates provision for adjustment of loading about any marked voltage, tests shall be conducted with the equipment adjusted so as to give maximum loading.</p> <p>Where tests in this Standard or in any individual Approval and test specification are to be conducted with</p>	Considered.	P

AS/NZS 3100:2009 / Amendment 1: 2010 / Amendment 2: 2012			
Clause	Requirement – Test	Result – Remark	Verdict
	<p>alternating current at a lagging power factor, the test circuit shall, unless otherwise specified, be a series circuit of an inductor and resistor.</p> <p>NOTE 2 Where iron-cored inductors are used, the peak flux density under steady state conditions should not exceed half the value at the knee point of the magnetization curve of the iron. Where an air-cored inductor is used, it should be shunted with a resistor of a value that will pass 1% of the main circuit current.</p> <p>The reference ambient temperature shall be 25°C unless it is clear by virtue of the design, application or marking that the equipment will usually operate in an ambient temperature higher than 25°C, in which case it shall be 40°C. Notwithstanding the foregoing, where an individual specification requires a test to be conducted under specified temperature conditions, or a particular reference ambient temperature is nominated, such temperatures shall apply in assessing the results of that test.</p> <p>If a test failure occurs, and unless otherwise specified, a suitably modified sample shall be submitted to all tests which may be affected by the modification, and any other tests which may be affected by these repeat tests; all tests being carried out in the correct order. Where the submission of a suitably modified sample is not made, three additional samples shall be required to withstand all tests relevant to the failure.</p> <p>If the test results are influenced by the temperature of the ambient air, the room temperature is, in general, maintained at 20°C ± 5°C. If, however, the temperature attained by any part is limited by a temperature-sensitive device, or is influenced by the temperature at which a change of state occurs, for example, the temperature of boiling water, the room temperature is, in case of doubt, maintained at 23°C ± 2°C.</p> <p>NOTE 3 Any test to be conducted at 23°C ± 2°C, on small equipment, may be carried out in a controlled test chamber of adequate size.</p>		
8.2	Void	Void.	N/A
8.3	Insulation resistance and leakage current		P
8.3.1	<p>Insulation resistance</p> <p>Insulation resistance shall be measured with a d.c. voltage of approximately 500V applied, the measurement being made 1min after application of the voltage –</p> <p>(a) between live parts and internal metal parts;</p> <p>(b) between live parts and the case, frame, or exposed metal parts;</p> <p>(c) between live parts and external metal parts;</p> <p>(d) between live parts and a flexible electrode applied to non-conductive parts normally handled in service; and</p> <p>(e) through supplementary insulation.</p> <p>The insulation resistance so measured shall not be less than 1MΩ between parts as detailed above in Items (a), (b) and (c) and not less than 10MΩ in all other cases.</p> <p>When performing the insulation resistance test on an accessory, any surge protection device, such as a varistor, may be disconnected during the test.</p>	Measurements were performed. See appended table.	P
8.3.2	<p>Leakage current test</p> <p>The leakage current of equipment shall not be excessive when assessed according to the following test.</p> <p>The leakage current is measured between any pole of the supply and accessible metal parts and metal foil</p>	IEC62109-1 is the product standard for testing and evaluation of this type of equipment. According to that	P

AS/NZS 3100:2009 / Amendment 1: 2010 / Amendment 2: 2012			
Clause	Requirement – Test	Result – Remark	Verdict
	<p>having dimensions not exceeding 200mm x 100mm in contact with accessible surfaces of insulating material, connected together.</p> <p>The connection diagram is shown in the following Figures.</p> <p>(a) For single-phase equipment having a rated voltage not exceeding 250 V, for three-phase equipment to be tested as single-phase equipment and for heating equipment for d.c. only</p> <p>(i) if of Class II.....Figure 8.3.2.1; or</p> <p>(ii) if other than Class II.....Figure 8.3.2.2.</p> <p>(b) For single-phase equipment having a rated voltage exceeding 250V and for three-phase equipment not suitable for single-phase supply</p> <p>(i) if of Class II.....Figure 8.3.2.3; or</p> <p>(ii) if other than Class II..... Figure 8.3.2.4.</p> <p>NOTE 1 See Annex E or Figure 4 of AS/NZS 60990 for details of measuring circuits shown in the connection diagrams as C.</p> <p>Single-phase equipment having a rated voltage exceeding 250 V are connected to two of the phase conductors.</p> <p>The test is made with a.c. unless the equipment is for d.c. only, in which case the test is made with d.c. except that motor-operated equipment for d.c. only are not tested.</p> <p>For single-phase equipment having a rated voltage not exceeding 250 V and for three-phase equipment to be tested as single-phase equipment, the leakage current is measured with the selector switch shown in Figures 8.3.2.1 and 8.3.2.2 in each of the positions 1 and 2.</p> <p>For other equipment, the leakage current is measured with the switches 'a', 'b' and 'c', shown in Figures 8.3.2.3 and 8.3.2.4, closed; for three-phase equipment not suitable for single-phase supply the measurements are repeated with each of the switches 'a', 'b' and 'c' open in turn, the other two switches being closed; for single-phase equipment, the measurements are repeated with one of the switches open.</p> <p>After the equipment has been operated until steady state conditions are established, the leakage current to accessible metal parts and metal foil shall not exceed the following values:</p> <p>(a) For Class III equipment..... 0.5mA.</p> <p>(b) For portable Class I equipment..... 0.75mA.</p> <p>(c) For stationary Class I motor-operated equipment3.5mA.</p> <p>(d) For stationary Class I heating equipment with heating elements which are detachable or can be switched off separately0.75mA or 0.75mA per kW rated input for each element or group of elements, whichever is the greater, with a maximum of 5mA for the equipment as a whole.</p> <p>(e) For other stationary Class I heating equipment..... 0.75mA or 0.75mA per kW rated input of the equipment, whichever is the greater, with a maximum of 5mA.</p> <p>(f) For Class II equipment..... 0.25 mA.</p> <p>(g) For other Class I equipment..... 5 mA.</p>	<p>standard the maximum level for leakage current is defined at 3,5mA. For equipment exceeding this value several additional measures are accepted, e. g. the PE conductor provides a minimum conductor cross-section of at least 10mm² of copper, or provisions for a second PE terminal are provided together with adequate information within the installation instructions.</p> <p>Due to both measures were applied on the EUT the leakage current test was accepted also for the AS3100.</p>	

AS/NZS 3100:2009 / Amendment 1: 2010 / Amendment 2: 2012			
Clause	Requirement – Test	Result – Remark	Verdict
	<p>If the equipment incorporates one or more capacitors and is provided with a single-pole switch, the measurements are repeated with the switch in the 'off' position.</p> <p>NOTE 2 For equipment incorporating both heating elements and motors, the total leakage current may be within the limits specified for heating equipment or for motor-operated equipment, whichever is the greater, but the two limits should not be added.</p> <p>NOTE 3 It is recommended that the equipment be supplied through an isolating transformer; otherwise, it should be insulated from earth.</p> <p>NOTE 4 The metal foil has the largest area possible on the surface under test, without exceeding the dimensions specified. If its area is smaller than the surface under test, it is moved so as to test all parts of the surface; the heat dissipation of the appliance should, however, not be affected by the metal foil.</p> <p>NOTE 5 The test with the switch in the 'off' position is made to verify that capacitors connected behind a single-pole switch do not cause an excessive leakage current.</p> <p>NOTE 6 If the equipment incorporates a thermal control which operates during the test of Clause 8.12 or the appropriate test in the individual Approval and test specification, the leakage current is measured immediately before the control opens the circuit.</p>		
8.4	High voltage (electric strength) test		P
8.4.1	<p>Between live parts</p> <p>All equipment shall withstand the application between live parts of an a.c. voltage of the value indicated in Table 8.4, according to the working voltage between the parts to which the test is being applied.</p>	Functional insulation was verified by performing short circuits.	N/A
8.4.2	<p>Equipment with earthing facilities</p> <p>All equipment with earthing facilities shall withstand the application between live parts and exposed metal or earth, of an a.c. voltage of the value indicated in Table 8.4, according to the working voltage between the live parts and exposed metal or earth.</p>	Considered. See appended table.	P
8.4.3	<p>Equipment with double insulation</p> <p>This test shall not apply to insulation that encloses only conductors or live parts operating at extra-low voltage supplied from a transformer complying with AS/NZS 61558.2.6.</p> <p>The insulation between live parts and external metal, or live parts and a flexible electrode applied to the surface of the insulation, shall withstand high voltages applied as follows:</p> <p>(a) Across basic insulation..... 1250V. (b) Across supplementary insulation..... 2500V.</p> <p>Where it is not possible to test the basic and supplementary insulation separately, or where a single layer of insulation is provided as the equivalent of separate layers of basic and supplementary insulation, a test voltage of 3750V shall be applied between live parts and external metal or live parts and a flexible electrode applied to the outer surface of the insulation.</p>	The EUT is a class I equipment.	N/A
8.4.4	<p>Non-conducting external parts</p> <p>An a.c. voltage of 3750V shall be applied between live parts and a flexible electrode applied to non-conducting parts normally handled in service.</p>	Considered. See appended table.	P
8.4.5	<p>Method of applying test</p> <p>When performing the insulation resistance test on an accessory, any surge protection device, such as a varistor, may be disconnected during the test.</p> <p>Any radio interference suppression devices shall remain connected during the following high voltage test. The test equipment and the test method shall be generally in</p>	Considered.	P

AS/NZS 3100:2009 / Amendment 1: 2010 / Amendment 2: 2012			
Clause	Requirement – Test	Result – Remark	Verdict
	<p>accordance with AS 1931.1 and AS 1931.2, as detailed below.</p> <p>To prevent overvoltages due to switching surges, the initial voltage shall not exceed 30% of the full test voltage and shall be increased uniformly to the full voltage in a time of not more than 30s. The full test voltage shall be maintained for 1 min after which the test voltage shall be diminished rapidly to 30% of its full value before switching off.</p> <p>The specified test voltage shall be maintained for the 1 min duration of the test within $\pm 3\%$.</p> <p>The test voltage shall be alternating, of any frequency between 25Hz and 100Hz, and approximately of sine waveform.</p> <p>There shall be no disruptive discharges, that is, flashovers or insulation punctures, during any high voltage tests.</p> <p>NOTE Where an individual Approval and test specification specifies an insulation resistance test immediately after the high voltage test, the insulation resistance test of Clause 8.3.1 is not repeated.</p> <p>The high voltage transformer used for the test shall be so designed that when the output terminals are short-circuited, after the output voltage has been adjusted to the appropriate test voltage, the output current shall be greater than 180mA. The overcurrent relay shall not trip when the output current is less than 100mA.</p>		
8.4.6	<p>Number of samples</p> <p>In cases where high voltage tests specified in any Specification would require the same insulation to be stressed more than once, the person submitting the equipment may submit, at the person's discretion, a sufficient number of samples to permit each such test to be made on a separate sample.</p>	Considered.	P
8.5	<p>Test of earthing connection</p> <p>The connection between the earthing terminal or earthing contact, and parts required to be connected thereto, shall be of low resistance.</p> <p>Compliance is checked by an earthing connection test, whereby a current derived from an a.c. source having a no-load voltage not exceeding 12V, and equal to 1.5 times rated current of the equipment or 25A, whichever is the greater, is passed between the earthing terminal or earthing contact, and each of the accessible metal parts in turn.</p> <p>The voltage drop between the earthing terminal of the equipment or the earthing contact of the appliance inlet and the accessible metal part is measured, and the resistance calculated from the current and this voltage drop.</p> <p>The resistance shall not exceed</p> <p>(a) for readily accessible exposed parts which rotate, reciprocate or oscillate continuously.....1Ω.</p> <p>(b) in all other cases..... 0.1 Ω.</p> <p>NOTE 1 In case of doubt, the test is carried out until steady conditions have been established.</p> <p>NOTE 2 The resistance of the flexible cord is not included in the resistance measurement.</p> <p>NOTE 3 Care is taken that the contact resistance between the tip of the measuring probe and the metal part under test does not influence the test results.</p>	Considered. See appended table.	P

AS/NZS 3100:2009 / Amendment 1: 2010 / Amendment 2: 2012			
Clause	Requirement – Test	Result – Remark	Verdict
	NOTE 4 For Item (a), a minimum current of 12A is acceptable.		
8.6	<p>Cord anchorage For the purpose of testing the cord anchorage, the equipment shall be wired in the normal manner with a flexible cord of the appropriate type. If the equipment is provided with an earthing terminal, the flexible cord shall include an earthing conductor. For Type X attachment, the conductors are introduced into the terminals, the terminal screws, if any, being tightened just sufficiently to prevent the conductors from easily changing their position. The cord anchorage is used in the normal way, its clamping screws being tightened with a torque equal to two-thirds of that specified in Table 8.7. The flexible cord shall be PVC-sheathed, unless otherwise specified in an individual Approval and test specification. Any sleeving or packing around the cord where it passes through the cord anchorage device shall be removed before the test is applied. The equipment is tested with the cord as delivered. It shall not be possible to push the cord into the equipment to such an extent that the cable or cord, or internal parts of the equipment, could be damaged. After the equipment has been correctly wired with all the strands intact, it shall be held fixed in position. The cord shall then be subjected 25 times to a pull of the value shown in Table 8.6. The pulls are applied in the most unfavourable direction without jerks, each time for 1s. Unless varied in an individual specification, accessories shall be subjected to a pull of 65 N. Immediately afterwards, the cord is subjected for 1 min to a torque of the value shown in Table 8.6. For Type X attachments having a specially prepared cord and Type Y and Z attachments, any additional sleeving used for cord protection purposes shall not be totally displaced from its anchorage point when tested. The sleeving shall be tested separately after the cord anchorage test in accordance with the method specified in this Clause; however, the pull shall be 30 N and the torque test shall not be applied. During the tests, the cord shall not be damaged. After the tests, the cord shall not have been longitudinally displaced by more than 2mm and the conductors shall not have moved over a distance of more than 1 mm in the terminals, nor shall there be appreciable strain at the connection. For the measurement of the longitudinal displacement, a mark is made on the cord while it is subjected to the pull, at a distance of approximately 20mm from the cord anchorage or other suitable point before starting the tests. After the tests, the displacement of the mark on the cord in relation to the cord anchorage or other point is measured while the cord is subjected to the pull.</p>	Considered. See appended table.	P
8.7	Test for screw threads and fixings (See Clause 4.7)		P
8.7.1	<p>Threaded fastenings of metal in metal or thermosetting plastic or wood, or the like The screwed component shall be tightened and loosened</p>	Considered. See appended table.	P

AS/NZS 3100:2009 / Amendment 1: 2010 / Amendment 2: 2012			
Clause	Requirement – Test	Result – Remark	Verdict
	<p>in a steady and uniform manner the following number of times, by means of a suitable test screwdriver or other appropriate device applying a torque of appropriate value given in Table 8.7:</p> <p>(a) Where it operates in a thread in metal..... 5 times. (b) Where it operates in a thread in insulating material 10 times.</p> <p>Screwed components operating in a thread in insulating material shall be completely removed and re-inserted for each operation.</p> <p>The shape of the blade of any test screwdriver shall be compatible with the slot of the screw to be tested.</p> <p>Threads of the screwed component and its fixing shall not strip, insulating material shall not crack, nor shall there be any other failure which would render the screwed component non-reusable.</p> <p>Where a screw is intended to secure a conductor, the test shall be carried out so that the stress is applied to the working section of the thread. Where applicable, the test shall be conducted with the appropriate conductor inserted in the terminal. For terminals that may be used for looping purposes, the test shall be conducted with the maximum and minimum number of conductors respectively which the terminal is intended to accommodate.</p>		
8.7.2	<p>Threaded fastenings with any component of thermoplastic material</p> <p>The length of thread engagement shall be measured and shall comply with Clause 4.7.</p> <p>The screwed components shall be tightened and loosened as described in Clause 8.7.1, except that the following procedure shall be used instead of the application of the specified torque values.</p> <p>The tightening shall be effected by first taking the screw up to the point where it bottoms and then tightening by a further 180° of turning or to the required torque in Table 8.7, whichever is reached first.</p> <p>NOTE Bottoming' refers to the condition where the screw has just gripped. If the test cannot be done by normal clamping, that is, where the point of grip cannot be positively identified, use may be made of a suitable parallel metal washer or distance piece under the head of the screw, provided that the minimum length of engagement of the fastening is observed.</p> <p>Threads of the fastening shall not jump or strip, insulating material shall not crack, nor shall there be any other failure which would render either component of the fastening non-reusable.</p> <p>Where a screw is intended to secure a conductor, the test shall be carried out so that the stress is applied to the working section of the thread.</p>	No thermoplastic threaded fastenings present.	N/A
8.8	Mechanical strength test		P
8.8.1	<p>General</p> <p>Equipment shall be subjected to blows, with an impact energy of $0.5 \pm 0.05\text{Nm}$, by any means having the same performances as the spring-operated impact-test apparatus described in Clauses 8.8.2 to 8.8.4.</p>	See clauses 8.8.2 to 8.8.4.	P
8.8.2	<p>Spring-operated impact-test apparatus</p> <p>The apparatus consists of three main parts, the body, the striking elements and the spring-loaded release cone as shown in Figure 8.8.2.</p>	Considered. See appended table.	P

AS/NZS 3100:2009 / Amendment 1: 2010 / Amendment 2: 2012			
Clause	Requirement – Test	Result – Remark	Verdict
	<p>The body comprises the housing, the striking element guide, the release mechanism and all parts rigidly fixed thereto. The mass of this assembly is 1250g.</p> <p>The striking element comprises the hammer head, the hammer shaft and the cocking knob. The mass of this assembly is 250g.</p> <p>The hammer head has a hemispherical face of polyamide having a Rockwell hardness of HR 100, with a radius of 10mm; it is fixed to the hammer shaft in such a way that the distance from its tip to the plane of the front of the cone when the striking element is on the point of release is 20mm.</p> <p>The cone has a mass of 60g and the cone spring is such that it exerts a force of 20N when the release jaws are on the point of releasing the striking element.</p> <p>The hammer spring is adjusted so that the product of the compression, in millimetres, and the force exerted, in newtons, equals 1000, the compression being approximately 20mm. With this adjustment, the impact energy is $0.5 \pm 0.05\text{Nm}$.</p> <p>The release mechanism springs are adjusted so that they exert just sufficient pressure to keep the release jaws in the engaged position.</p> <p>The apparatus is cocked by pulling the cocking knob until the release jaws engage with the groove in the hammer shaft.</p> <p>The blows are applied by pushing the release cone against the sample in a direction perpendicular to the surface at the point to be tested.</p> <p>The pressure is slowly increased so that the cone moves back until it is in contact with the release bars, which then move to operate the release mechanism and allow the hammer to strike.</p>		
8.8.3	<p>Procedure</p> <p>The sample as a whole is rigidly supported against a plane surface and three blows are applied to every point of the enclosure that is likely to be weak.</p> <p>To ensure that the sample is rigidly supported, it may be necessary to place it against a solid wall of brick, concrete or the like, covered by a sheet of polyamide which is tightly fixed to the wall, care being taken that there is no appreciable air gap between the sheet and the wall. The sheet shall have a Rockwell hardness of HR 100, a thickness of at least 8mm and a surface area such that no part of the sample is mechanically overstressed due to insufficient supporting area.</p> <p>If necessary, the blows are also applied to handles, levers, knobs and the like, and to signal lamps and their covers, but only if the lamps or covers protrude from the enclosure by more than 10mm or if their surface area exceeds 400mm^2. Lamps within the equipment, and their covers, are only tested if they are likely to be damaged in normal use.</p>	Considered.	P
8.8.4	<p>Criteria</p> <p>After the test, the sample shall show no damage within the meaning of this Specification; in particular, live parts shall not have become exposed so as to impair compliance with Clauses 5.1 and 5.2, and there shall not have been such distortion as to impair compliance with</p>	Considered.	P

AS/NZS 3100:2009 / Amendment 1: 2010 / Amendment 2: 2012			
Clause	Requirement – Test	Result – Remark	Verdict
	<p>Clause 4.1.3. In case of doubt, supplementary insulation is subjected to an electric strength test as specified in Clause 8.4.3.</p> <p>If there is a doubt as to whether a defect has been promoted by the application of preceding blows, this defect is neglected and the group of three blows which led to the defect is applied to the same place on a new sample, which shall then withstand the test.</p> <p>NOTE 1 When applying the release cone to the guard of a heating element which glows visibly in normal use, care should be taken that the hammer head passing through the guard does not strike the heating element.</p> <p>NOTE 2 Damage to the finish, small dents that do not reduce creepage distances and clearances below the values specified in Clause 4.1.3, and small chips that do not adversely affect the protection against electrical shock or moisture, are disregarded.</p> <p>NOTE 3 Cracks not visible to the naked eye and surface cracks in fibre-reinforced mouldings and the like are ignored.</p> <p>NOTE 4 If a decorative cover is backed by an inner cover, fracture of the decorative cover is neglected if the inner cover withstands the test after removal of the decorative cover.</p> <p>NOTE 5 For the calibration of the spring-operated impact-test apparatus see AS 60068.2.75.</p>		
8.9	<p>Standard electrodes for electric strength tests</p> <p>Where the electric strength of a material in sheet form is to be tested, the electrodes used shall be constructed of solid brass. The electrodes shall be in the form of solid brass cylinders, one of 75mm diameter by 25mm depth, and the other of 38mm diameter by 38mm depth. Where the electric strength over a surface is to be tested, the same pair of electrodes, or two of the latter size, may be used.</p>	Considered.	P
8.10	<p>Standard test finger and protective impedance</p>		P
8.10.1	<p>General</p> <p>For the purpose of determining whether or not either live parts (see Clause 5.1) or non-current-carrying conductive parts are exposed to personal contact, use shall be made of the standard test finger.</p>	Considered.	P
8.10.2	<p>Design and construction</p> <p>The standard test finger, as shown in Figure 8.10, shall be so designed that each of the jointed sections can be turned through an angle of 90°C with respect to the axis of the finger in the same direction only.</p> <p>The tip of the finger shall be made of copper or copper alloy; the handle shall be made of insulating material. The finger shall be provided with two joints operating in the same plane and so constructed that they will remain in any desired position.</p> <p>A terminal or other equivalent means shall be provided to permit attachment of a flexible wire lead to the finger.</p>	Considered.	P
8.10.3	<p>Method of use</p> <p>The standard test finger may be applied directly to the live or non-current-carrying conductive part in question and a visual examination made to determine whether or not the finger is in contact with the part under test. The test finger shall be applied in every possible position, making use of the joints incorporated, provided that where bending takes place at both joints the direction of bending at each joint shall be the same, either clockwise or anti-clockwise.</p> <p>Where, however, there is any doubt as to whether contact is made or whether a given part is live, the</p>	Considered. See appended table.	P

AS/NZS 3100:2009 / Amendment 1: 2010 / Amendment 2: 2012			
Clause	Requirement – Test	Result – Remark	Verdict
	flexible wire lead from the test finger shall be connected through a high-resistance voltmeter having a resistance of not less than 1000Ω/V of the scale reading, or other convenient indicator of equivalent current sensitivity, to one pole of a battery (6V to 12V) the other pole of which shall be connected to the supply terminals or points of the inner wiring of the equipment, which shall be entirely disconnected from the supply mains during this test.		
8.10.4	<p>Protective impedance Protective impedance shall consist of at least two separate components, the impedances of which are unlikely to change significantly throughout the life of the equipment. If any one of the components is short-circuited or open-circuited, the current between the part and the supply source shall not exceed 2mA for d.c. and its peak value shall not exceed 0.7mA for a.c., and also the following shall apply:</p> <p>(a) For potentials not exceeding 450V peak, the capacitance shall not exceed 0.1μF. (b) For potentials not exceeding 15000V peak, the quantity of electricity in the discharge shall not exceed 45μC. (c) For potentials exceeding 15000V peak, the energy in the discharge shall not exceed 350mJ.</p> <p>Voltage, current and capacitance are measured between the relevant part and either pole of the supply source, the equipment being supplied at rated voltage. Discharge parameters are measured immediately after interruption of the supply, ensuring that the method of interruption of the supply does not break the connection to earth of one of the poles of the supply source. The circuit for measuring the current is that of Annex E or that in Figure 4 of AS/NZS 60990. The quantity of electricity or energy in the discharge shall be measured into a load consisting of a non-inductive resistor of 2000Ω. Resistors or capacitors used as protective impedances shall comply with Clause 14.1(a), or Clause 14.2 of AS/NZS 60065, as appropriate.</p>	Each protective impedance within the unit consists of at least 8 separate 560kΩ resistors. In the event of a single fault there remain 7 resistors with a total resistance of nearly 4MΩ. A current of less than 0,06mA per protective impedance can be calculated. This value can be neglected in respect to the required limit.	N/A
8.11	Temperature measurements		P
8.11.1	<p>Methods of measurement Three methods of measuring temperatures are recognized, (a) thermometer method; (b) thermocouple method; and (c) increase-of-resistance method.</p>	Thermocouple method was used.	P
8.11.2	<p>Thermometer method Three types of thermometer may be employed, viz. bulb thermometers containing either mercury or alcohol, and resistance thermometers. Where bulb thermometers are used to measure the temperature of a surface, one or other of the following procedures shall be adopted, whichever is appropriate to the particular case: (a) The bulb shall be surrounded by a single wrapping of tinfoil having a thickness of not less than 0.03mm. The foil shall be turned up at the end to form a complete covering for the bulb, which shall then be secured in</p>	Thermocouple method was used.	N/A

AS/NZS 3100:2009 / Amendment 1: 2010 / Amendment 2: 2012			
Clause	Requirement – Test	Result – Remark	Verdict
	<p>contact with the surface under test. The exposed part of the wrapped bulb shall be completely covered with a pad of heat-insulating material without unduly shielding the test surface from normal cooling.</p> <p>(b) The bulb, except at the point of contact, shall be covered with a pad of felt, cotton wool, or other non-conducting material 3mm thick, extending at least 19.0mm in every other direction from the bulb and pressed into contact with the surface to which it is applied to prevent loss of heat by radiation and convection from the bulb.</p> <p>Any thermometers used shall be of marked immersion and known accuracy.</p>		
8.11.3	<p>Thermocouple method</p> <p>The two conductors between which the thermo-electric effect is produced shall be welded or hard-soldered at both the hot and the cold junctions, care being taken to ensure that the wires at the junction make contact at one point only, and are not twisted together.</p> <p>The standard No. 1 thermocouple shall be a base metal couple made up of wires not smaller than 0.213mm and not larger than 0.315mm.</p> <p>The standard No. 2 thermocouple shall be a base metal couple made up of wires not smaller than 0.457mm and not larger than 0.559mm and with insulation suitable for use at 350°C.</p> <p>Thermocouples shall be affixed in a manner appropriate to the case, for example by tying, clamping, wedging, or soldering.</p> <p>Where a thermocouple is soldered to a portion of the article under test, care shall be taken to avoid appreciable modification of the physical characteristics of the article by the temperature or the fluxes used in the soldering process.</p> <p>Measurements of the thermal e.m.f. should be made with suitable equipment (potentiometer or direct-reading instrument). If the test equipment is not provided with cold-junction compensation, the cold-junction should be contained in a vacuum flask containing crushed ice.</p>	<p>Thermocouple method was used.</p> <p>See appended table.</p>	P
8.11.4	<p>Increase-of-resistance method</p> <p>The increase-of-resistance method is suitable for the measurement of the average temperature of coils or windings.</p> <p>The appropriate equations to be used are contained in Note 2 to Table 5.7.</p> <p>An approximate method is to calculate the temperature rise of the conductor on the basis of 1°C for each 0.4% increase of resistance.</p> <p>It should be noted that this method provides no indication of any points of temperature higher than average.</p>	<p>Thermocouple method was used.</p>	N/A
8.11.5	<p>Measurement of ambient temperature</p> <p>The temperature of the ambient air shall be measured by at least two thermometers protected against radiation from the object under test. For the purpose of the Standard, ambient temperature shall be considered as the average of readings recorded at 10min intervals during the final 30min of the test.</p>	<p>Considered.</p> <p>See appended table.</p>	P
8.11.6	<p>Maximum temperature rise</p> <p>The maximum temperature rise shall be taken to have</p>	<p>Considered.</p>	P

AS/NZS 3100:2009 / Amendment 1: 2010 / Amendment 2: 2012			
Clause	Requirement – Test	Result – Remark	Verdict
	been reached when for one 30min period the mean temperature curve for the object under test retains the same nominal temperature difference above ambient temperature.		
8.12	<p>Temperature and fire risk test</p> <p>Any material or insulation of equipment and the surfaces of the test surroundings referred to below shall not attain excessive temperatures in normal use.</p> <p>Except for hand-held tools, compliance shall be checked by determining the temperature of the surrounds, and material or insulation, where appropriate, under the following conditions (for hand-held tools, the material and insulation temperature requirements only shall apply):</p> <p>Built-in type equipment shall be installed in a normal manner in an enclosure consisting of a bottom, a back, two sides and where appropriate a top. The enclosure shall be constructed of dull-black-painted 10mm to 20mm thick particleboard sections. A clearance of 10mm shall be maintained between the equipment and each of the surfaces of the enclosure except where installation instructions normally supplied with the equipment nominate a clearance which is to be observed, but in no case shall the clearance exceed 50mm.</p> <p>Hand-held equipment shall be suspended in still air. Other equipment shall be placed in a right angle test corner comprising two dull black painted walls and separate floor and ceiling sections, being stood or mounted on the appropriate surface so that they are as close to the other surfaces as is likely to occur in normal use, account being taken of any installation instructions provided with the equipment.</p> <p>Fixed equipment and accessories intended for connection to fixed wiring shall be subject to the following test conditions, only where called up by an individual Approval and test specification:</p> <p>(a) The device shall be mounted in a substantially draught-free location in the most arduous manner likely to be experienced in normal service.</p> <p>(b) The connecting cables shall</p> <p>(i) be single-core, PVC-insulated, copper cables or wires with cross-sectional areas as given in Table 8.12;</p> <p>(ii) be stripped to the minimum length required to effect the intended connection of the device under test;</p> <p>(iii) be unenclosed; and</p> <p>(iv) have a minimum length of</p> <p>for cross-sections up to and including 10mm².... 1m; or</p> <p>for cross-sections larger than 10mm².... 2m.</p> <p>(c) The appropriate test current, at rated voltage, shall be passed through the device for a period of 2h, or until temperatures are stable, whichever is the lesser.*</p> <p>* Where heavy current equipment is not affected by the test voltage, the voltage applied during the test may be lower than rated voltage.</p> <p>Notwithstanding the foregoing, if the cable entries of the equipment are designed to accommodate only a special type of cable then an appropriately rated cable of that type shall be used for the test.</p> <p>The temperature of any material or insulation and the test surrounds shall be determined by means of fine wire</p>	Considered.	P

AS/NZS 3100:2009 / Amendment 1: 2010 / Amendment 2: 2012			
Clause	Requirement – Test	Result – Remark	Verdict
	<p>thermocouples so chosen and positioned that they have minimum heat sink effect on the item under test and so that they touch items likely to attain the highest temperatures. The thermocouples shall be attached to the back of blackened discs of copper or brass, 15mm diameter and 1mm thick, and which are themselves attached to the surface of the surround. Other temperatures shall be measured in accordance with Clause 8.11.</p> <p>The equipment shall be operated at maximum normal load while connected to a supply of rated voltage for the rated time for short-time rated units, and until steady state conditions are attained for intermittent-rated and continuously rated units.</p> <p>During the test, over temperature cut-outs shall not operate.</p> <p>Any equipment that is maintained at a constant temperature by means of a thermostat or other suitable means (such as boiling water) during the test shall be tested at the appropriate reference ambient temperature. Where appropriate, the surface temperature of the surrounds shall not exceed 90°C. The temperature of any material measured as above and corrected to the reference ambient temperature specified in Clause 8.1, or any other relevant Approval and test specification, shall not exceed the limits specified in Clauses 5.7 and 6.2 or in the relevant Approval and test specification, as appropriate.</p> <p>In addition, the temperature of the insulation of the connecting cables, where relied upon to prevent short-circuit or contact with material through which leakage may occur, shall not exceed the temperature rating of the cables used for this test.</p> <p>NOTE The leakage current test of Clause 8.3.2 may be performed in conjunction with the temperature test.</p>		
8.13	<p>Test of marking</p> <p>Nameplates, transfers and paintings used to provide the information required in accordance with Clause 7.1 shall be checked by inspection and by rubbing by hand for 15 s with a piece of cloth soaked with water and again with a piece of cloth soaked with petroleum spirit. At the completion of these tests, the marking shall comply with Clause 7.2.</p> <p>This test does not apply to any marking provided on the container in which the article is supplied.</p> <p>NOTE The petroleum spirit to be used for the test is aliphatic solvent hexane having a maximum aromatics content of 0.1% by volume, a kauri-butanol value of 29, an initial boiling point of approximately 65°C, a dry point of approximately 69°C and a specific mass of approximately 0.68kg/L.</p>	<p>Tests were performed. See appended table.</p>	P
8.14	<p>Stability test</p> <p>Freestanding equipment intended for use on a surface such as a floor or a table shall have adequate stability. Compliance is checked by a stability test, equipment provided with an appliance inlet being fitted with an appropriate connector and flexible cord.</p> <p>The equipment is placed, with the motor switched off, in any normal position of use on a plane inclined at an angle of 10°C to the horizontal, the cord resting on the inclined plane in the most unfavourable position. If, however, the equipment is such that, were it to be tilted</p>	<p>The EUT is fixed (wall mounted).</p>	N/A

AS/NZS 3100:2009 / Amendment 1: 2010 / Amendment 2: 2012			
Clause	Requirement – Test	Result – Remark	Verdict
	<p>through an angle of 10°C when standing on a horizontal plane, a part of it not normally in contact with the supporting surface would touch the horizontal plane, the equipment is placed on a horizontal support and tilted in the most unfavourable direction through an angle of 10°C.</p> <p>Equipment with doors is tested with the doors open or closed, whichever is the more unfavourable.</p> <p>Equipment intended to be filled with liquid by the user in normal use is tested empty or filled with the most unfavourable quantity of water up to the rated capacity.</p> <p>The equipment shall not overturn.</p> <p>NOTE The test on the horizontal plane may, for example, be necessary for equipment provided with rollers, castors or feet.</p>		
8.15	Abnormal operation		P
8.15.1	<p>General</p> <p>Equipment shall be so designed that the risk of fire, mechanical damage impairing safety or the protection against electric shock as a result of abnormal or careless operation is obviated as far as is practicable.</p> <p>Compliance is checked as follows and by the tests of Clauses 8.15.2 to 8.15.8, as appropriate, all thermostats and temperature limiters being short-circuited or otherwise rendered inoperative and the equipment shall then comply with the tests of Clause 8.15.9; and the tests shall be conducted under the general test conditions specified in Clause 8.12:</p> <p><i>(a) Equipment with heating elements</i></p> <p>Equipment with heating elements is tested according to Clause 8.15.2.</p> <p>If, during the tests, a non-self-resetting thermal cut-out operates or the current is otherwise interrupted in a non-self-resetting way before steady conditions are established, the heating period is considered to be ended, but if the interruption is due to the rupture of a heating element or of an intentionally weak part, the relevant test is repeated on a second sample which shall then also comply with the conditions specified in Clause 8.15.9.</p> <p>NOTE 1 Rupture of a heating element or of an intentionally weak part in the second sample will not in itself entail a rejection.</p> <p>NOTE 2 An intentionally weak part is a part designed to fail under conditions of abnormal operation so as to prevent the occurrence of a condition that is unsafe within the meaning of this Standard. Such a part may be a replaceable component, such as a resistor, a capacitor or a thermal fuse, or a part of a component to be replaced, such as an inaccessible and non-resettable thermal cut-out incorporated in a motor.</p> <p><i>(b) Motor-operated equipment</i></p> <p>For motor-operated equipment without heating elements, compliance is checked by the tests of Clauses 8.15.3 to 8.15.8, as applicable.</p> <p><i>(c) Combined equipment</i></p> <p>For combined equipment, all tests are carried out.</p> <p><i>(d) Equipment incorporating electronic components</i></p> <p>For equipment incorporating components such as semiconductor devices, capacitors, resistors or inductors, the failure of which might cause a hazard, compliance is checked by the test of Clause 8.15.8.</p> <p>If in any of the tests the interruption of current is the result of the operation of a thermal cutout, the cut-out</p>	Considered.	P

AS/NZS 3100:2009 / Amendment 1: 2010 / Amendment 2: 2012			
Clause	Requirement – Test	Result – Remark	Verdict
	<p>shall be caused to operate, while interrupting the maximum current measured during the test, over a period of</p> <p>(i) three operations for non-self-resetting thermal cut-outs requiring replacement of a part, a new part being fitted for each operation;</p> <p>(ii) six successive operations for non-self-resetting thermal cut-outs requiring resetting by hand; or</p> <p>(iii) 200 successive operations for self-resetting thermal cut-outs.</p> <p>For resetting protective devices, the period between successive operations shall be kept as short as possible, consistent with any inherent time delay of the device.</p> <p>NOTE 3 Fuses, thermal cut-outs, overcurrent releases or the like, incorporated into the equipment, may be used to provide the necessary protection.</p> <p>NOTE 4 If more than one of the tests are applicable for the same appliance, these tests are made consecutively.</p>		
8.15.2	<p>Heating equipment test</p> <p>Equipment with heating elements is tested under the conditions specified in Clause 8.12, the supply voltage being such that the input is equal to rated input.</p> <p>If a non-self-resetting thermal cut-out operates, or if the current is otherwise interrupted in a non-self-resetting way before steady conditions are established, the operating period is considered to be ended.</p> <p>If interruption of the current does not occur, the equipment is operated until steady conditions are established.</p> <p>For equipment for short-term operation, the duration of the test is equal to the rated operating time.</p>	The EUT do not provide heating elements.	N/A
8.15.3	<p>Locked-rotor test</p> <p>A locked-rotor test is made by locking moving parts of the equipment</p> <p>(a) has moving parts liable to be jammed;</p> <p>(b) has motors with a locked rotor torque smaller than the full-load torque;</p> <p>(c) has motors to be started by hand;</p> <p>(d) is intended to be remotely or automatically controlled; or</p> <p>(e) is liable to be operated while unattended.</p> <p>NOTE 1 If the equipment has more than one motor, the test is made for each motor separately.</p> <p>Equipment incorporating motors having capacitors in the circuit of an auxiliary winding is operated with the rotor locked, the capacitors, one at a time, being short-circuited or open-circuited, whichever is the more unfavourable, unless the equipment is not intended for use unattended and the motor is provided with a capacitor complying with IEC 60252-1.</p> <p>NOTE 2 This test is made with the rotor locked because certain motors with capacitors might or might not start so that variable results could be obtained.</p> <p>For each of the tests, the equipment, starting from room temperature, is operated at rated voltage or at the upper limit of the rated voltage range for a period of</p> <p>(i) 30s for</p> <p>(A) hand-held equipment;</p> <p>(B) equipment that has to be kept switched on by hand; and</p> <p>(C) equipment that is continuously loaded by hand; or</p>	The fan motor was tested accordingly. See appended table.	P

AS/NZS 3100:2009 / Amendment 1: 2010 / Amendment 2: 2012			
Clause	Requirement – Test	Result – Remark	Verdict
	<p>(ii) 5 min or, if a timer is provided, equal to the max. period allowed by the timer, for other equipment that is not intended for use unattended; or</p> <p>(iii) as long as necessary to establish steady conditions or, if a timer is provided, equal to the maximum period allowed by the timer for the remaining equipment.</p> <p>NOTE 3 The particular specification indicates which equipment has moving parts liable to be jammed or are liable to be operated while unattended.</p> <p>At the end of the test period specified, or at the instant of operation of fuses, thermal cut-outs, motor protection devices and the like, the temperature of the windings shall not exceed the values shown in Table 8.15.3.</p>		
8.15.4	<p>Equipment with three-phase motors</p> <p>Equipment incorporating three-phase motors is operated under normal load, with one phase disconnected, for a period as specified in Clause 8.15.3.</p>	No three-phase motor provided.	N/A
8.15.5	<p>Running overload test</p> <p>A running overload test is made on equipment incorporating motors that are either intended to be remotely or automatically controlled, or liable to be operated continuously while unattended, the equipment being operated under normal load, at rated voltage or at the upper limit of the rated voltage range, until steady conditions are established.</p> <p>The load is then increased in appropriate steps so that the current through the motor windings is raised, the supply voltage being maintained at its original value. When new steady conditions are established, the load is again increased. This operation is repeated until the overload protection device operates or until the motor stalls.</p> <p>NOTE 1 If the load cannot be increased in appropriate steps in the equipment, it will be necessary to remove the motor from the equipment and to test the motor separately.</p> <p>NOTE 2 The particular specification indicates which equipment is liable to be operated continuously while unattended.</p> <p>The winding temperature is continuously measured and noted during each period of steady conditions, and the maximum temperature value recorded shall not exceed</p> <p>(a) for Class 105 (A) material 140°C (b) for Class 120 (E) material 155°C (c) for Class 130 (B) material 165°C (d) for Class 155 (F) material 180°C (e) for Class 180 (H) material 200°C (f) for Class 200 material 220°C (g) for Class 220 material 240°C (h) for Class 250 material 270°C</p>	Refer to clause 8.15.3.	N/A
8.15.6	<p>Equipment for short-time or intermittent operation</p> <p>Equipment for short-time or intermittent operation, other than hand-held equipment, equipment that has to be kept switched on by hand, equipment that is continuously loaded by hand, or equipment with a timer, is operated under normal load and at rated voltage or at the upper limit of the rated voltage range, until steady conditions are established, or until the thermal cut-out operates. When steady conditions are established, or immediately before the operation of the thermal cut-out, the temperature of the windings shall not exceed the values specified in Clause 8.15.5.</p> <p>NOTE If in normal use the equipment unloads itself after a certain</p>	The EUT is intended for continuous operation.	N/A

AS/NZS 3100:2009 / Amendment 1: 2010 / Amendment 2: 2012			
Clause	Requirement – Test	Result – Remark	Verdict
	period, the test is continued with the appliance running idle.		
8.15.7	<p>Equipment with series motors Equipment incorporating series motors is operated at a voltage equal to 1.3 times rated voltage, for 1min, with the lowest possible load. Any heating elements shall be disconnected for this test. After this test, the safety of the equipment shall not have been impaired; in particular, windings and connections shall not have worked loose.</p>	No such motor provided.	N/A
8.15.8	<p>Equipment incorporating electronic components The equipment is operated at a supply voltage so that the input is equal to rated input. Components such as semiconductor devices, capacitors, resistors or inductors, the failure of which might cause a hazard, are short-circuited or disconnected, whichever is the more unfavourable. If a non-self-resetting thermal cut-out operates or if the current is otherwise interrupted in a non-self-resetting way before steady conditions are established, the operating period is considered to be ended. If interruption of the current does not occur, the equipment is operated until steady conditions are established. For equipment for short-term operation, the duration of the test is equal to the rated operating time. Positive temperature coefficient resistors (PTCs), negative temperature coefficient resistors (NTCs) and voltage dependent resistors (VDRs) are not short-circuited if they are used within their manufacturer's declared Specification. NOTE 1 The short-circuits and disconnections are applied one at a time and, associated with them, those other fault conditions which are a logical consequence thereof. NOTE 2 Examination of the equipment and its circuit diagram will, in general, show the fault conditions which should be applied. These are applied consecutively in the most convenient order. NOTE 3 Components complying with Clause 14 of AS/NZS 60065 are, for the purposes of this Clause, not considered likely to fail.</p>	For safety dependent components refer to "list of safety critical components". Each component which was considered to cause a hazard was short circuited.	P
8.15.9	<p>Test results During the tests of Clauses 8.15.2 to 8.15.8, the equipment shall not emit flames or molten metal, or poisonous or ignitable gas in hazardous amounts, enclosures shall not deform to such an extent as will impair compliance with this Specification and temperature rises shall not exceed the values shown in Table 8.15.9. After the tests, the insulation of equipment other than that of Class III, when cooled down to approximately room temperature, shall withstand an electric strength test as specified in Clause 8.4 the test voltage being (a) for basic insulation 1000V; (b) for supplementary insulation 2750V; (c) for reinforced insulation 3750V. For equipment that is to be immersed in or filled with conducting liquid in normal use, the sample is immersed in or filled with water, as appropriate, for 24h before the electric strength test is made.</p>	Considered. No flames or molten metal emitted. Additionally the EUT provide a fire enclosure. After the tests the electric strength was applied.	P

AS/NZS 3100:2009 / Amendment 1: 2010 / Amendment 2: 2012			
Clause	Requirement – Test	Result – Remark	Verdict
Annex A (Normative) Requirements from the 1994 edition			
The following requirements, taken from the 1994 edition of AS 3100, are applicable to equipment that is not designated as 'attended' or 'unattended'.			
SECTION 5: PROTECTION AGAINST RISK OF ELECTRIC SHOCK FOOTNOTES TO TABLE 5.7 <small>e There is no specific limit for thermoplastic material.</small>			
SECTION 6: PROTECTION AGAINST HEAT AND FIRE			
A 6.1	Resistance to fire	The EUT was tested according to Annex B.	N/A
A 6.1.1	<p>General requirements for compliance of solid insulating materials and non metallic enclosures</p> <p>Compliance of solid insulating materials and non metallic materials of electrical accessories is checked by the tests detailed in A 6.1.2 to A 6.1.7.</p> <p>Guidance for the selection and sequence of tests is given in the flow chart figure A1.</p> <p>Glow-wire test apparatus and common test procedure is given in AS/NZS 60695.2.10.</p> <p>Glow-wire flammability test method for end-products is given in AS/NZS 60695.2.11. This includes guidance for the test temperature, a definition of small parts and evaluation of test results.</p> <p>In addition to the evaluation requirements of AS/NZS 60695.2.11 the complete product has failed to comply with the glow-wire tests if burning droplets or glowing particles escape from the equipment and ignite the tissue paper or scorch the particle board underlay beneath the specimen.</p> <p>The glow-wire test temperature 'T' is required to be specified in each product specification.</p> <p>The test method for Needle-Flame Test is given in AS/NZS 60695.11.5. This includes an evaluation of test results.</p>		N/A
A 6.1.2	<p>Materials and tests</p> <p>The tests are carried out on solid insulating materials and non metallic enclosure whilst assembled on a complete end product.</p> <p>The tests are not carried out on decorative trims, insulation of wires, knobs and other small parts unlikely to be ignited or to propagate flames originating from inside the equipment.</p>		N/A
A 6.1.3	<p>Glow-wire tests on relevant parts</p> <p>Relevant parts, other than those in A 6.1.4 are subjected to the glow-wire test of AS/NZS 60695.2.11, which is carried out at 650°C, unless otherwise specified in the relevant product standard.</p> <p>Note The majority of thermoplastic materials are capable of complying with the 550°C GWT and consequently where the material is adequately specified and certified this test may be waived with the agreement of the test authority.</p> <p>The glow-wire test is not carried out on parts of material classified at least HB40 according to AS/NZS 60695.11.10, provided that the test sample was no thicker than the relevant part.</p>		N/A
A 6.1.4	<p>Glow-wire tests on retaining parts</p> <p>Parts of insulating material retaining current carrying parts carrying more than 0.2amps in position, are</p>		N/A

AS/NZS 3100:2009 / Amendment 1: 2010 / Amendment 2: 2012			
Clause	Requirement – Test	Result – Remark	Verdict
	<p>subjected to the glow-wire test of AS/NZS 60695.2.11 which is carried out at the glow-wire test temperature 'T' specified in the product standard.</p> <p>NOTE Where no product standard exists the appropriate test temperature may be obtained from the guidance for glow-wire tests given in Annex A of AS/NZS 60695.2.11.</p> <p>If parts tested withstand the glow-wire test, but during the test produce a flame that persists for longer than 2s, then the consequential needle flame test of A 6.1.5 applies.</p>		
A 6.1.5	<p>Consequential needle flame test</p> <p>a) The needle-flame test of A 6.1.7 is applied to all parts of non-metallic material (including barriers and enclosures) that are likely to be ignited by and are positioned within a distance of 50mm of those parts that flamed during the glow-wire test of A 6.1.4.</p> <p>Note The needle flame test should be applied, wherever possible from inside the enclosure.</p> <p>b) The needle-flame test of A 6.1.7 is also applied to those parts, outside the 50 mm specified above, that were contacted by the flame, subjected to burning droplets or glowing particles when the glow-wire test was conducted in accordance with A 6.1.4.</p> <p>c) The needle-flame test of A.6.1.7 is also applied to those parts that were contacted by the flame or subjected to burning droplets or glowing particles when the needle-flame test was conducted in accordance with A 6.1.5 b) above.</p> <p>The needle-flame test is not carried out on parts of material classified as V-0 or V-1 according to AS/NZS 60695.11.10, provided that the test sample was no thicker than the relevant part.</p>		N/A
A 6.1.6	<p>Needle flame tests on printed circuit boards</p> <p>The base material of printed circuit boards is subjected to the needle-flame test of A 6.1.7.</p> <p>The 12mm flame is applied to an edge of the board not less than 10mm from a corner. If the board is horizontal in the normal position of use, the board is tested in the horizontal position, the flame being applied to the edge that has the lowest heat sink.</p> <p>For all other board mounting positions, the board shall be tested vertically with the flame applied to the lower edge.</p> <p>The test is not carried out:</p> <p>i) on the printed circuit boards in a metal enclosure that confines flames or burning droplets;</p> <p>ii) if the material is classified as V-0 according to AS/NZS 60695.11.10, provided that the test sample was no thicker than the printed circuit board.</p> <p>NOTE 1 For this test, the printed circuit board may be tested without circuit components, if the submitter wishes. This is a more onerous test condition but this would permit a change of component without necessitating a retest.</p> <p>NOTE.2 If the printed circuit board is tested with components mounted and a component ignites during the test, this would not constitute a failure of the board, unless the component ignites the board.</p>		N/A
A 6.1.7	<p>Needle-flame test method</p> <p>The needle-flame test shall be carried out in accordance with AS/NZS 4695.2.2 with the following modifications.</p> <p>a) for the purpose of Clause 7 of AS/NZS 60695.11.5, the duration of application of the test flame is 30s ± 1s;</p> <p>b) for the purpose of Clause 9.1 of AS/NZS 60695.11.5, the specimen is arranged so that the flame can be</p>		N/A

AS/NZS 3100:2009 / Amendment 1: 2010 / Amendment 2: 2012			
Clause	Requirement – Test	Result – Remark	Verdict
	<p>applied to a vertical or horizontal edge;</p> <p>c) for the purpose of Clause 9.2 of AS/NZS 60695.11.5, the first paragraph of 8.4 does not apply. If possible, the flame is applied at least 10mm from a corner;</p> <p>d) for the purpose of Clause 9.3 of AS/NZS 60695.11.5, the test is carried out on one specimen. If the specimen does not withstand the test, the test may be repeated on two further specimens, both of which shall then withstand the test;</p> <p>e) for the purpose of Clause 11 of AS/NZS 60695.11.5, the duration of burning (tb) shall not exceed 30s. However, for printed circuit boards, it shall not exceed 15s. Slight discolouration of the particle board is ignored.</p>		
A 6.2	<p>Temperatures of surfaces to be handled</p> <p>The temperature rise of surfaces intended to be touched, when tested in accordance with Clause 8.12, shall not exceed the values specified in Table 5.7.</p>		N/A
A 6.3	<p>Resistance to tracking</p> <p>Insulating material across which a tracking path may occur between live parts of different polarity or between live parts and earthed metal parts, and insulating material of commutators and brush-caps, shall have adequate resistance to tracking, taking into account the severity of its duty conditions.</p> <p>For parts of insulating material other than ceramic, compliance is checked by the proof tracking test specified in AS/NZS 60112.</p> <p>For parts of insulating material used under severe duty conditions, the test voltage is 175V. If the specimens do not withstand this test and there is no hazard other than fire, surrounding parts are subjected to the needle-flame test referred to in Clause 6.1.5.</p> <p>For parts of insulating material used under extra-severe duty conditions, the test voltage is 250V. If the specimens do not withstand this test, but withstand the test made with a test voltage of 175V, and there is no hazard other than fire, surrounding parts are subjected to the needle-flame test referred to in Clause 6.1.5.</p> <p>The needle-flame test is made on all parts of non-metallic material positioned within a distance of 50mm from any place where a tracking path may occur, unless these parts are shielded by a separate barrier or enclosure from that tracking path, in which case the barrier or enclosure is subjected to the needle flame test.</p> <p>NOTE 1 Guidelines for the duty conditions are given in Annex P of AS/NZS 60335.1.</p> <p>NOTE 2 There are no tracking requirements for insulation considered to be subjected to normal duty conditions.</p> <p>NOTE 3 Unless otherwise varied in the particular Standard, the severity will be considered as normal duty.</p>		N/A

AS/NZS 3100:2009 / Amendment 1: 2010 / Amendment 2: 2012			
Clause	Requirement – Test	Result – Remark	Verdict
Annex B (Normative) Tests of resistance to heat, fire and tracking			
B 1	Introduction The tests in this Annex shall be used to determine resistance to heat, fire and tracking.	Considered.	P
B 2	Resistance to heat test Unless varied in a particular specification, compliance is checked by subjecting the relevant part to the ball pressure test by means of the apparatus shown typically in Figure B2. Before starting the test, the relevant part is maintained for 24h in an atmosphere having a temperature between 15°C and 35°C and a relative humidity between 45% and 75%. The part is supported so that its upper surface is horizontal and the spherical part of the apparatus is pressed against this surface with a force of 20 N. The thickness of the part under test shall be at least 2.5mm. NOTE: If necessary, the required thickness may be obtained by using two or more sections of the part. The test is made in a heating cabinet at a temperature of 40°C ± 2°C plus the maximum temperature rise determined during the test of Clause 8.12, but it shall be at least (a) for external parts..... 75°C ± 2°C; (b) for parts supporting live parts..... 125°C ± 2°C. However, for parts of thermoplastic material providing supplementary insulation or reinforced insulation, the test is made at a temperature of 25°C ± 2°C plus the maximum temperature rise determined during the tests of Clause 8.15, if this is higher. The temperature rises of Clause 8.15.1 are not taken into account if the test of Clause 8.15 is terminated by the operation of a non-self-resetting protective device and it is necessary to remove a cover or to use a tool to reset it. Before the test is started, the test apparatus is brought to the temperature determined above. After 1h the apparatus is removed and the part is immediately immersed in cold water so that it is cooled to approximately room temperature within 10s. The diameter of the impression shall not exceed 2mm. NOTE 1 For coil formers, only those parts which support or retain terminals in position are subjected to the test. NOTE 2 The test is not made on parts of ceramic material.	Considered. See appended table.	P
B 3	Resistance to fire tests	Considered. See appended table.	P
B 3.1	General Unless varied in a particular specification, compliance is checked by the tests of Paragraph B3.2 and the applicable parts of Paragraph B3.3. Guidance on the application of glow-wire and needle-flame tests is given in Figure B3.		P
B 3.2	Materials and tests Relevant parts of non-metallic material are subjected to the glow-wire test of AS/NZS 60695.2.10, on the appropriate part of the equipment, the test being made at a temperature of 550°C. Insulating materials of winding bobbins and formers are		P

AS/NZS 3100:2009 / Amendment 1: 2010 / Amendment 2: 2012			
Clause	Requirement – Test	Result – Remark	Verdict
	<p>subjected to the glow-wire test of AS/NZS 60695.2.10, the test being made at a temperature of 650°C.</p> <p>Base material of printed wiring boards together with any coating or encapsulation shall comply with the needle-flame test of Paragraph B3.4; however, flames shall have extinguished within 15s of removal of the test flame.</p> <p>The flame shall be applied to an edge of the board having the lowest heat sink effect, with the board orientated in its normal position of use and at a point, if possible, not less than 10mm from a corner.</p> <p>NOTE 1 The needle-flame test is not carried out on printed wiring boards contained in a metal enclosure that would prevent flame or burning droplets escaping.</p> <p>NOTE 2 If the printed wiring board is tested with components mounted and a component ignites during the test, this does not constitute a failure of the board material unless it is ignited by the component.</p> <p>NOTE 3 If evidence is provided that a printed wiring board, together with any coating, has been given a rating of V-0 when tested to AS/NZS 60695.11.10 or equivalent requirements, this test may be waived.</p>		
B 3.3	<p>Glow-wire test</p> <p>For equipment that is operated while attended, parts of insulating material supporting, in contact with or within 3mm to current-carrying connections, other than those in low-power circuits determined as described in Clause 19.11.1 of AS/NZS 60335.1, are subject to the glow-wire test of AS/NZS 60695.2.10, the test being made at a temperature of 650°C.</p> <p>However, parts of insulating material supporting, in contact with or within 3mm to screw connections that carry a current exceeding 0.5A during normal operation and which are likely to be made or remade during installation, user maintenance or when replacing a supply cord assembled with the appliance by a Type X attachment, are subject to the glow-wire test of AS/NZS 60695.2.10, the test being made at a temperature of 750°C.</p> <p>Where an insulating material is within 3mm of a current carrying connection but is shielded from the connection by a different insulating material that itself is in contact with the current carrying connection, the glow-wire test is carried out at the relevant temperature on the shielded insulating material as follows.</p> <p>The glow-wire tip is applied to the insulating material to be tested via the shielding insulating material, the glow-wire tip penetration limit of 7mm ± 0.5mm being reduced to 3mm ± 0.2mm.</p> <p>This test is not made on hand-held appliances, on appliances that have to be kept switched on by hand or foot and on appliances that are continuously loaded by hand.</p> <p>For equipment that is operated while unattended, parts of insulating material supporting, in contact with or within 3 mm to current carrying connections, other than those in low-power circuits determined as described in Clause 19.11.1 of AS/NZS 60335.1, are subject to the glow-wire test of AS/NZS 60695.2.10, the test being made at a temperature of 750°C.</p> <p>However, parts of insulating material supporting, in contact with or within 3mm to screw connections, which carry a current exceeding 0.5A during normal operation and which are likely to be made or remade during</p>		P

AS/NZS 3100:2009 / Amendment 1: 2010 / Amendment 2: 2012			
Clause	Requirement – Test	Result – Remark	Verdict
	<p>installation, user maintenance or when replacing a supply cord assembled with the appliance by a Type X attachment, are subject to the glow-wire test of AS/NZS 60695.2.10, the test being made at a temperature of 850°C.</p> <p>Where an insulating material is within 3mm of a current carrying connection but is shielded from the connection by a different insulating material that itself is in contact with the current carrying connection, the glow-wire test is carried out at the relevant temperature on the shielded insulating material as follows.</p> <p>The glow-wire tip is applied to the insulating material to be tested via the shielding insulating material, the glow-wire tip penetration limit of 7mm ± 0.5mm being reduced to 3mm ± 0.2mm.</p> <p>NOTE 1 The test is not carried out on parts supporting welded connections.</p> <p>NOTE 2 Whether equipment is considered to be attended or unattended will be stated in the particular specification. Where there is no particular specification, guidance should be sought from a specification covering equipment of a similar kind.</p> <p>During application of the glow-wire the height and duration of flames are measured.</p> <p>In addition, for equipment that is operated while unattended with parts that withstand the glow-wire test but which flame during the application of the glow-wire, the surrounding parts are subjected to the needle-flame test of Paragraph B3.4 for the measured duration of the flame or 30s, whichever is the least, if</p> <p>(a) they are positioned within a distance equal to the height of the flame; and</p> <p>(b) they are likely to be impinged upon by the flame.</p> <p>Surrounding parts shielded by a separate barrier that meets the needle-flame test of Paragraph B3.4 are not tested.</p> <p>If parts, other than enclosures, do not withstand the test of Paragraph B3.3 by failure to extinguish within 30s after removal of the glow-wire tip, the needle-flame test of Paragraph B3.4 is made on all parts of non-metallic material that are within a distance of 50mm or that are likely to be impinged upon by flame during the test of Paragraph B3.3. Parts shielded by a separate barrier that meets the needle-flame tests are not tested.</p> <p>NOTE 1 If the enclosure does not withstand the glow-wire test, the equipment is considered to have failed to meet the requirement of Clause 6.2 without the need for consequential testing.</p> <p>NOTE 2 If other parts do not withstand the glow-wire test due to ignition of the tissue paper and if this indicates that burning or glowing particles can fall onto an external surface underneath the equipment, the equipment is considered to have failed to meet the requirement of Clause 6.2 without the need for consequential testing.</p> <p>NOTE 3 Parts likely to be impinged upon by the flame are considered to be those within the envelope of a vertical cylinder having a radius of 10 mm and a height equal to the height of the flame, positioned above the point of the material supporting, in contact with or in close proximity to connections.</p>		
B 3.4	<p>Needle-flame test</p> <p>The needle-flame test shall be carried out in accordance with AS/NZS 60695.11.5. For the purposes of Clause 11 of AS/NZS 60695.11.5, slight discolouration of the particle board is ignored</p>		P
B 4	<p>Resistance to tracking test</p> <p>Insulating material across which a tracking path may</p>	Already certified PCBs provided.	N/A

AS/NZS 3100:2009 / Amendment 1: 2010 / Amendment 2: 2012			
Clause	Requirement – Test	Result – Remark	Verdict
	<p>occur shall have adequate resistance to tracking, taking into account the severity of its duty condition. A tracking path is considered likely to occur between live parts of different potential, live parts and earthed metal parts, and across insulating material of commutators and brush-caps.</p> <p>For parts of insulating material other than ceramic and phenolic, compliance is checked by the proof tracking test specified in IEC 60112.</p> <p>For parts of insulating material used under severe duty conditions, the test voltage is 175V. If the specimens do not withstand this test and there is no hazard other than fire, surrounding parts shall comply with the needle-flame test referred to in Paragraph B3.4.</p> <p>For parts of insulating material used under extra-severe duty conditions, the test voltage is 250V. If the specimens do not withstand this test, but withstand the test made with a test voltage of 175V, and there is no hazard other than fire, surrounding parts shall comply with the needle-flame test referred to in Paragraph B3.4.</p> <p>The needle-flame test is made on all parts of non-metallic material positioned within a distance of 50mm from any place where a tracking path may occur, unless these parts are shielded by a separate barrier or enclosure from that tracking path, in which case the barrier or enclosure is subjected to the needle-flame test.</p> <p>NOTE 1 Guidelines for the duty conditions are given in Annex P of AS/NZS 60335.1.</p> <p>NOTE 2 There are no tracking requirements for insulation considered to be subjected to normal duty conditions.</p> <p>NOTE 3 Experience has shown that surface tracking tests carried out on parts of phenolic material give unrepeatable results. Such tests are no longer carried out.</p>		

AS/NZS 3100:2009 / Amendment 1: 2010 / Amendment 2: 2012			
Clause	Requirement – Test	Result – Remark	Verdict
Annex C (Normative) Measurement of creepage distances and clearances			
C	<p>The methods of measuring creepage distances and clearances to be used in interpreting the requirements of Clause 4.1.3 are indicated in Cases 1 to 10 of this Annex.</p> <p>These cases do not differentiate between gaps and grooves or between types of insulation.</p> <p>The following assumptions are made:</p> <p>a) A groove may have parallel, converging or diverging sides.</p> <p>(b) Any groove having diverging sides, a min. width exceeding 0.25mm, a depth exceeding 1.5mm and a width at the bottom equal to or greater than 1mm, is regarded as an air gap (see Case 8).</p> <p>(c) Any corner including an angle less than 80° is assumed to be bridged with an insulating link of 1mm width (0.25mm for dirt-free situations) moved into the most unfavourable position (see Case 3).</p> <p>(d) Where the distance across the top of a groove is 1mm (0.25mm for dirt-free situations) or more, no creepage distance exists across the air space (see Case 2).</p> <p>(e) A creepage path is assumed not to exist if there is an air gap as defined in Item (b) exceeding 0.25mm.</p> <p>(f) Creepage distances and clearances measured between parts moving relative to each other are measured when these parts are in their most unfavourable stationary positions.</p> <p>(g) A computed creepage distance is never less than a measured clearance.</p> <p>(h) Any air gap less than 1mm wide (0.25mm for dirt-free situations) is ignored in computing the total creepage distance.</p>	Considered.	P

AS/NZS 3100:2009 / Amendment 1: 2010 / Amendment 2: 2012			
Clause	Requirement – Test	Result – Remark	Verdict
Annex D (Informative) Information on the safety principles of the design and testing of electrical equipment including insulationencased and metal-encased class II construction			
D 1	The risk of electric shock Since the human body is to some extent a conductor of electricity, a current will flow through the tissues when contact is made simultaneously with two objects that are at different potentials. Thus, if the two terminals of a source of electricity are grasped, one in each hand, current will flow through the body. The current that flows may be imperceptible at very low voltages, but lethal at higher voltages. A similar effect will be produced if only one terminal of a supply is touched, provided that, as is usual, the power supply is tied to earth and the person is standing on a floor that is not well-insulated from earth. Voltages below 32V are usually considered to be harmless to ordinarily healthy people under normal circumstances. Consequently, no precautions are taken generally to prevent a userfrom coming into contact with the conducting parts of a safety-extra-low-voltage system. Public supply systems, however, are of the order of 250V (relative to earth potential) and a shock from them can be dangerous. Hence, it is necessary to prevent the user of electrical equipment from making contact with any 'live' part of the system, that is to say, any part whose potential is, or may become, different from earth potential. It might be thought that safety would be ensured if no part of the supply system were connected to earth; while this would be so as long as the insulation were adequately maintained, the system would not, in practice, be safe, because the potential might fortuitously rise to any value above earth. By deliberately earthing one point of the system, the maximum potential to earth that can occur is limited to a value that is known and can be guarded against. In Australia and New Zealand all low voltage supply systems are required to be earthed and the most commonly used method of earthing electrical installations is the multiple earthed neutral (MEN) system. This system is a variant of the TN-C-S system used in some other parts of the world.	The EUT is a class I equipment.	N/A
D 2	Protection of live parts In the interests of safety, no equipment for connection to electricity supply mains should have any live parts accessible to the user. The protective screen or case may be of insulating material, or of metal if it is insulated from the current-carrying parts. Any such apertures should be so arranged in the form of baffled louvers or the like so that there is no possibility of a finger passing through them and coming into contact with live parts or unearthed metal.		N/A
D 3	Earthing of class I equipment If the protective case is of metal, a failure of the protection, which might occur through breakdown of the insulating material or bridging of insulation, such as the escape of a strand of flexible cord from under a clamping		N/A

AS/NZS 3100:2009 / Amendment 1: 2010 / Amendment 2: 2012			
Clause	Requirement – Test	Result – Remark	Verdict
	<p>screw to bridge the gap to the case, could raise the potential of the case to a hazardous voltage above earth. This would be an extremely dangerous condition, because persons touching the case would be likely to receive a dangerous shock if they were making partial contact with earth, or a fatal shock if they were in good contact with earth through standing on a wet floor or touching water pipes, gas pipes, or other earthed metal. It is therefore desirable in the interests of safety to provide a second line of defence, and the National Wiring Rules requires, generally, that any metal in an electrical installation that can be touched shall be 'earthed'; that is to say, electrically connected to the general mass of earth and to the earthed point of the supply system by conductors of low resistance.</p> <p>So long as this condition is maintained, there can be no danger in touching the metal, for even in the event of failure of insulation, no appreciable potential can exist between it and persons who are also making contact with earth.</p> <p>If the failure of insulation is partial, a small current will flow through the earth wire harmlessly to earth, while if it is complete, a heavy current will flow, which will operate protective devices (fuses or circuit-breakers) in the live conductors and disconnect the power supply.</p> <p>If earthing is to be relied upon for protection, it is essential that portable equipment should be connected to the mains by means of plugs and sockets that incorporate an earthing connection. If two-pin plugs and sockets or lampholder adaptors are used, no such protection is afforded. Equipment having metal cases that are not earthed are not allowed in Australia or New Zealand (Class 0 and Class 0I equipment), unless the equipment is of Class II construction as described in Paragraphs D5 and D6.</p> <p>NOTE Definitions for Class 0 and Class 0I equipment are contained in AS/NZS 60335.1.</p>		
D 4	<p>Monitored earthing connections</p> <p>There are in existence systems for detecting the presence of leakage current to earth or a rise in potential of accessible metal, and which disconnects the supply to minimize the risk of electric shock. Other systems may activate alarms or switch off the power supply to the equipment, unless the earth circuit is complete.</p>		N/A
D 5	<p>Insulation-encased class II construction</p> <p>In this form of Class II construction, the equipment is totally enclosed in a casing made of insulating material, having no external metal whatever, and having no apertures through which a probe can be inserted to touch live metal or basic insulation. Where the insulating case is made strong enough to withstand service conditions without fracture or deterioration, and when the equipment is suitable for conditions of use, such as wet or dry conditions, this is probably the safest form of construction.</p> <p>The principles of design of insulation-encased Class II equipment are simple and should require no explanation. Such equipment should not forfeit the description 'insulation encased' because it has relatively small metal parts accessible from the outside of the enclosure, such</p>		N/A

AS/NZS 3100:2009 / Amendment 1: 2010 / Amendment 2: 2012			
Clause	Requirement – Test	Result – Remark	Verdict
	<p>as screws, name plates, or guards, separated from live parts by insulation that is thick, and by visible creepage paths that are so long, that the chance of their becoming live through failure of the insulating path is extremely remote. Such insulation and creepage paths should, as a minimum, comply with the requirements for reinforced insulation.</p> <p>Not all equipment can be manufactured using the 'insulation-encased' form of construction, for example electric hair clippers, hedge clippers and portable tools, which require some external metal in order to perform their proper function. Accordingly, a form of construction known as double insulation has been devised.</p>		
D 6	Metal-encased class II construction		N/A
D 6.1	<p>Principles of double insulation</p> <p>As its name implies, double insulation involves the provision of two completely separate sets of insulation between the current-carrying parts and any metal accessible to the user. If either set of insulation breaks down, or accidentally becomes short-circuited by conductor strands or by other metal, it will not result in risk to the user, who will be protected by the second set of insulation. The accessible metal parts will become live only in the event of breakdown of both sets, and the chances of this occurring are much less than the chances of the breakdown of either set alone.</p>		N/A
D 6.2	<p>Design of metal-encased Class II equipment</p> <p>Metal-encased equipment should be so designed that, in general, failure of two independent sections of insulation must occur before any external surface can become electrically connected with live conductors.* Each section of insulation should alone be amply sufficient to withstand the normal working voltage of the equipment without breakdown or appreciable leakage, even under damp conditions, so that if either section fails, safety is assured by the second section. The insulation adjacent to the live conductors is referred to as 'basic insulation', and the second layer as 'supplementary insulation'. Alternatively, the supplementary insulation may be in the form of a maintained air gap of adequate dimension.</p> <p>It is not always possible or indeed necessary to comply fully with this ideal of two independent sections of insulation in order to achieve an adequate measure of safety. In certain circumstances, a single layer of insulation is sometimes used where the principles of two distinct layers of insulation cannot be applied reasonably in equipment intended to be double insulated.</p> <p>This single layer of insulation has to be of a special nature, both in respect of quality and in the method of incorporation in the equipment, to be accepted as affording protection equivalent to that provided by the two independent layers of insulation. This single layer is referred to as reinforced insulation. In addition to passing the test specified for double insulation, the continued effectiveness of the single layer of insulation under normal conditions of use should be assessed having regard to such factors as</p> <p>a) mechanical strength, resistance to shrinking and warping, and the like;</p>		N/A

AS/NZS 3100:2009 / Amendment 1: 2010 / Amendment 2: 2012			
Clause	Requirement – Test	Result – Remark	Verdict
	(b) resistance to moisture; (c) security of mounting and fixing in the equipment; (d) accidental bridging of the insulation by extraneous metal objects; (e) resistance to tracking due to deposits of foreign matter (for example, carbon dust and the like) (see Clause 5.4.4); and (f) protection against heat and fire (see Section 6). * Failure of insulation in this context is taken to include the accidental bridging of an insulating gap by metal or partially conducting material such as carbon dust or moisture, as well as electrical breakdown in the conventional sense.		
D 6.3	<p>Methods of achieving double insulation</p> <p>The following are different forms of construction in which the principle of double insulation can be incorporated:</p> <p>(a) A continuous and substantial layer of metal is interposed between basic and supplementary insulation, illustrated diagrammatically in Figure D1(a). A defect starting in the basic insulation, whether it be an electrical puncture or a mechanical fracture, may grow until it reaches the metal layer but is unlikely to spread into the supplementary insulation. It is necessary to arrange that the supplementary insulation has electric strength and insulation resistance substantially greater than the minimum required for the basic insulation. The required degree of safety is proved by testing the insulation between live metal and the metal layer and the insulation between the metal layer and exposed metal, and ensuring that each is adequate by itself.</p> <p>(b) There is a metal layer interposed between the basic insulation and the supplementary insulation, but this layer and the basic insulation are not complete and some bare live conductors are left separated only by air from the supplementary insulation. This is shown in Figure D1(b). Here the necessary degree of safety is proved by the same tests as in Item (a), supplemented by inspection to make certain that none of the bare conductors can, in service, become displaced from the normal position so as to touch the supplementary insulation and thus short-circuit the air insulation. In Figure D1(b) the supplementary insulation is shown pierced by a hole, which might be necessary for ventilation. Ideally there should be no openings giving access to the inside of the enclosing case, but when necessary for the proper functioning of the equipment such holes should be so sized and disposed that a finger or implement cannot be pushed through to touch either live metal or the conducting layer. This is shown symbolically in Figure D1(b) by an aperture having a tortuous path.</p> <p>(c) The live parts are completely enclosed in basic insulation, which is itself enclosed in supplementary insulation without the interposition of any metal layer as shown in Figure D1(d). In this case, in order to comply with the principle of 'double improbability', the supplementary and basic insulations should be of such mechanical and electrical characteristics that a failure of either is unlikely to spread to the other. If they have to be of the same material, they should at least be mechanically distinct, so that there is a surface of discontinuity to prevent the spread of deterioration from</p>		N/A

AS/NZS 3100:2009 / Amendment 1: 2010 / Amendment 2: 2012			
Clause	Requirement – Test	Result – Remark	Verdict
	<p>one to another. Each section of insulation should be designed so that by itself it would be capable of withstanding the tests applicable to basic or supplementary insulation, as appropriate.</p> <p>(d) A variation of the type in Item (c) is shown in Figures D1(c) and D1(e), where the live conductors are not completely surrounded by solid basic insulation, but are partly separated by air from the supplementary insulation. The supplementary insulation may have a hole through it as in Figure D1(e).</p> <p>It is also possible that metal work connected to neither live conductors nor accessible metal is embedded in the supplementary insulation, as shown in Figure D1(f). Inspection and tests on the supplementary insulation as a whole should be made to ensure that the presence of the metal inclusions does not reduce the effectiveness of the supplementary insulation below the limit of acceptance.</p> <p>In practice, the construction of double insulation equipment need not be solely in accordance with any one of the above four types and two or more types may be combined in one article for convenience.</p> <p>It will be apparent that with double-insulated equipment built in accordance with these principles and made to a specification recognized for this purpose by electrical supply authorities where they are applicable, it is unnecessary to earth the accessible metal. Any means for so doing should not be provided.</p>		
D 6.4	<p>Connection to the power supply</p> <p>In designing double-insulated equipment it is important to remember that the principle should be extended to auxiliary items such as switches, plugs and sockets, and also to any apertures through which the supply cord may be led in. If, in portable equipment, the flexible cord is a two-core cord sheathed with elastomer or PVC compound, it might be thought that since the insulation around the conductors and that comprising the sheath were of mechanically and electrically different characteristics, the conductor could pass through a hole in unearthed external metal without breaking the principle of double insulation. However, in view of the fact that the cord is particularly vulnerable at the point of entry into portable equipment, because of the repeated bending that occurs there, this is not considered to be safe and equipment may well fail to qualify for classification as double-insulated, unless the flexible cord enters either through a hole in insulating material as shown in Figure D1(g) or through a properly secured insulating bush if the case is of metal as in Figure D1(h).</p>		N/A
D 7	Classification of the tests involved		N/A
D 7.1	<p>General</p> <p>To ensure that electrical equipment is safe when it leaves the factory, tests are necessary to establish the following general requirements:</p> <p>(a) The design is such that there is no likelihood of danger to the user or surroundings in normal use or in the event of such careless use as may occur in normal service, and that the materials used will not deteriorate to such an extent that the equipment becomes unsafe (see</p>		N/A

AS/NZS 3100:2009 / Amendment 1: 2010 / Amendment 2: 2012			
Clause	Requirement – Test	Result – Remark	Verdict
	<p>Paragraph D7.2).</p> <p>(b) During the course of production, no unapproved changes in design have been made (see Paragraph D7.3).</p> <p>(c) Each item of equipment has been assembled correctly and that no significant departure from the component or materials specifications has occurred (see Paragraph D7.4).</p>		
D 7.2	<p>Type tests</p> <p>To ensure the first general requirement is being met, a comprehensive series of tests is required. These tests are known as 'type tests'.</p> <p>NOTE As such tests involve conditions not encountered in normal use, the equipment subjected to these tests may be unsafe for further use.</p> <p>A type test is a test, or a series of tests, that is made on a sample of one or more specimens for the purpose of checking compliance of the design of a given product with the requirements of the Standard concerned. It is not necessary to repeat this series of tests, unless and until the manufacturer decides to make a change.</p> <p>Such tests are contained in the main body of this Standard and in particular Approval and test specifications.</p>		N/A
D 7.3	<p>Surveillance tests</p> <p>To ensure that the second of the general requirements is being met, manufacturers, testing organizations or purchasers should select samples at random and at a frequency according to their own discretion. Such samples should then be subjected to some or all of the tests specified in the relevant Standard, as considered necessary.</p>		N/A
D 7.4	<p>Production tests</p> <p>To satisfy the third of the general requirements, it is necessary for the manufacturer to undertake production tests. These tests will in general comprise routine tests, but if it is not possible or practicable to carry out all the tests that might be considered desirable on each individual item of equipment, reliance may be placed on sampling tests. The frequency of sampling will depend upon the extent to which the production process is likely to vary.</p> <p>Production tests are made as follows:</p> <p>(a) <i>Routine tests</i> Routine tests are made on each item of equipment. Details of routine tests are given in Paragraph D8.</p> <p>(b) <i>Sampling tests</i> Sampling tests are not made on each item of equipment, but on a proportion diverted from the production line for this purpose.</p> <p>If the manufacturer requires such tests or if they are specified, the way in which the tests are to be applied and the action to be taken in the event of a departure from the requirements should be documented.</p>		N/A
D 8	Requirements for routine tests		N/A
D 8.1	<p>General</p> <p>To ascertain that the equipment has been correctly assembled, routine tests should be made on every individual item, usually at one or more suitable testing points on the production line. Such tests should not therefore damage any product that is in accordance with</p>		N/A

AS/NZS 3100:2009 / Amendment 1: 2010 / Amendment 2: 2012			
Clause	Requirement – Test	Result – Remark	Verdict
	<p>the typetested sample, in any way. For this reason, the tests may often have to be less stringent than the type tests.</p> <p>Usually, routine tests are made as part of the final inspection procedure.</p> <p>It is not, however, always possible or practicable to apply the tests after complete assembly. In these cases, an intermediate test position should be set up, as near as is reasonable to the last point in the assembly line, when access to the necessary parts can still be obtained.</p> <p>No one series of tests will be universally applicable, but tests to determine the following are suggested as a basis where specific tests are not laid down for particular equipment:</p> <p>(a) The insulation is effective.</p> <p>(b) The earthing of Class I equipment has good continuity.</p> <p>(c) Cord anchorage and terminal connections are properly assembled.</p> <p>(d) Wiring and components are correctly fitted and positioned.</p> <p>(e) The equipment functions correctly.</p> <p>The tests necessary to check these items are described in Paragraphs D8.2 to D8.6.</p>		
D 8.2	<p>Effectiveness of insulation</p> <p>The effectiveness of insulation is checked by an electric strength test. However, as the purpose of the test is mainly to check correctness of assembly, it is not necessary to apply such high voltage for such times as are called for in the type test specified in the relevant Standard. Indeed, it is essential that there should be no risk of deterioration or premature failure due to overstress. This is particularly important when applying the test voltage between live parts and accessible metal parts to test reinforced insulation in Class II equipment. The way in which the stress is apportioned between live parts, intermediate metal parts and accessible metal, where there is true double insulation, depends upon the relative impedance of basic insulation and supplementary insulation.</p> <p>A decision should be made whether the test is to be made by applying the original test voltage for a shorter time, by reducing the test voltage, or by impulse testing; the latter may involve higher voltages.</p>		N/A
D 8.3	<p>Continuity of earthing of Class I equipment</p> <p>The continuity of earthing can be checked by the test described in the relevant Standard; the check is to see that necessary connections have been made. To avoid the possibility of deterioration due to local overheating, a lower current than that called for in the type test may be passed for a shorter time.</p>		N/A
D 8.4	<p>Assembly of cord anchorage and terminal connections</p> <p>An inspection is necessary to ensure that all screws have been tightened and that snap-on, crimped or similar connections have been correctly assembled.</p>		N/A
D 8.5	<p>Correct position of wiring and components</p> <p>The correct positioning and retention of wiring and components should be checked by inspection.</p>		N/A

AS/NZS 3100:2009 / Amendment 1: 2010 / Amendment 2: 2012			
Clause	Requirement – Test	Result – Remark	Verdict
D 8.6	Correct functioning of the equipment The test program should include appropriate tests for the correct functioning of the equipment and safety devices.		N/A
D 8.7	Selection of tests It may not always be necessary to examine all of the criteria mentioned above. For example, it might be possible to dispense with the electric strength test in Paragraph D8.2 in favour of adequate inspection of creepage distances while inspection in Paragraph D8.5 would in general only be applied in cases where inadequate retention or incorrect positioning could lead to danger. The tests in Paragraph D8.6 apply in general only to equipment such as motor-operated appliances and heating appliances. In some cases additional tests may be necessary. A decision should be made whether the production tests are to be routine tests or sampling tests.		N/A
D 8.8	Segregation of defective products It is essential that all defective items are segregated from production until the items have been repaired and retested or destroyed.		N/A
D 9	Production test equipment The following applies to production test equipment: (a) The manufacturer should be able to demonstrate (i) that the equipment, apparatus and instruments for the tests are suitable for their purpose; and (ii) that checks are made at sufficiently frequent intervals to ensure that their accuracy is maintained. (b) Essential operating instructions for test equipment should be maintained and should be readily available to the operator. (c) Adequate records should be maintained for the test equipment showing (i) means of identification (where appropriate); and (ii) frequency of check tests and details of repairs.		N/A

AS/NZS 3100:2009 / Amendment 1: 2010 / Amendment 2: 2012			
Clause	Requirement – Test	Result – Remark	Verdict
Annex E (Informative) Circuit for measuring leakage currents			
E 1	General A suitable circuit for measuring leakage currents in accordance with Clause 8.3.2 is shown in Figure E1.	Considered. See appended table.	P
E 2	Circuit components The circuit comprises two basic parts (a) a resistance, capacitance shunt whose impedance changes with frequency; and (b) a high impedance r.m.s. responding a.c. voltmeter whose indication is virtually independent of frequency over the range 20Hz to 5000Hz. The shunt consists of a parallel combination of a resistance of $1750\Omega \pm 250\Omega$ and a capacitor such that the time constant of the circuit is $225\mu s \pm 15\mu s$. The resistor has a tapping of 1000Ω from one end for connection to the voltmeter. The voltmeter, of internal resistance not less than $1M\Omega$, and an error of $\pm 5\%$ or less over the frequency range of 20Hz to 5000Hz is to be connected across the 1000Ω portion of the shunt resistance so that its indication in volts r.m.s. will be a direct measure of leakage current in milliamperes r.m.s. at 50Hz. Suitable overload protection may be provided for the voltmeter to prevent damage to the instrument due to excessive leakage current. A resolution of at least 0.01V is required for the voltmeter. A typical circuit of the arrangement is shown in Figure E1.		P

AS/NZS 3100:2009 / Amendment 1: 2010 / Amendment 2: 2012			
Clause	Requirement – Test	Result – Remark	Verdict
Annex F (Normative) Heat behaviour test			
F 1	<p>General</p> <p>Where required by a particular Standard the heat behaviour test shall be applied to the complete equipment to determine whether all insulating materials adequately maintain minimum safety requirements on exposure to elevated temperatures for a specified time. Where this is not practicable the test shall be applied to a sub- assembly or component.</p> <p>NOTE 1 Examples of failure of minimum safety requirements are exposure of live parts and warping of enclosures or barriers which may reduce their effectiveness in containing any flames or bring them within an area which would require them to be subjected to other fire tests.</p> <p>NOTE 2 The particular product Standard may indicate that an appropriate sub-assembly or component may be tested separately where a particular portion of an equipment or accessory may be subjected to localized elevated temperatures.</p> <p>NOTE 3 The test is not applicable to liquid materials, gaseous materials or ceramic and similar inorganic materials.</p> <p>NOTE 4 This test is generally based on the mould stress-relief distortion test of UL 746C.</p>	No required by this standard.	N/A
F 2	<p>Test specimen</p> <p>The test specimen shall be the complete equipment, except that when this is not practicable for test purposes it shall be a complete sub-assembly or component mounted in such a way as to simulate intended use. If not otherwise specified, the test specimen should be stored at 25°C ± 10°C and a relative humidity of 60% ± 15% for 24h immediately before the test. The test specimen shall be placed in an oven and heated at a predetermined temperature for a period of time.</p>		N/A
F 3	<p>Test apparatus</p> <p>The test apparatus shall consist of an air-circulating oven capable of maintaining the temperature of its test space within ± 3°C of the test temperature specified in Paragraph F4.</p>		N/A
F 4	<p>Test method</p> <p>The test method shall be as follows:</p> <p>a) The oven control shall be adjusted to a setting which produces a test temperature 10K higher than the highest temperature attained during conditions of normal use or 70°C, whichever is the higher. The oven shall be maintained at that setting for the duration of the test.</p> <p>NOTE It is recommended that the relevant product Standard indicates which is the test under conditions of normal use.</p> <p>b) The test specimen shall be positioned within the heated oven in the most unfavourable position likely to occur in normal use. The test specimen shall not be energized during the test.</p> <p>c) During the test, temperatures of external surfaces of the insulating enclosure shall be measured and temperatures of surfaces of components or sub-assemblies shall be measured within the equipment. Where the test is applied to sub-assemblies or components the temperature of the surfaces of the sub-assembly or component shall be measured.</p> <p>d) The test specimen shall be allowed to remain in the oven for 7h after the measured temperature has reached the lower limit of the test temperature. The test specimen</p>		N/A



AS/NZS 3100:2009 / Amendment 1: 2010 / Amendment 2: 2012			
Clause	Requirement – Test	Result – Remark	Verdict
	shall then be carefully removed and allowed to cool to room temperature.		
F 5	Tests results After the tests, inspection of the specimen shall be carried out. The following shall apply: a) There shall be no exposure of live parts or bridging of live parts to accessible conductive parts. NOTE 1 A suitable test is made with the standard test finger. b) There shall be no change to the acceptable mechanical protection to internal parts of the equipment. NOTE 2 A suitable test is the application of the test of Clause 8.8. c) There shall be no impairment of the normal operation of the equipment to the extent that the equipment fails the requirements of other tests of the appropriate Standard, for example IR, HV and tests of leakage current.		N/A

Annex No. 1

Additional Test Data

3.3	Selection of materials and parts				P
3.4	Selection of components (list of critical components)				
Object/Part No.	Manufacturer/Tra demark	Type/Model	Technical data	Standard	Mark(s) of conformity
SMA Sunny Island 4.4M					
Enclosure Cover	+ Fritz Schmidt	Aluminium	Overall approx. dimension: 612 mm by 467 mm by 84 mm by min. 2,7 mm thickness Provided with Control Unit		Accepted
Enclosure Rear panel	+ Fritz Schmidt	Aluminium	Overall approx. dimension: 593,8 mm by 434,6 mm by min. 2 mm thickness		Accepted
Enclosure Cover for rear panel	+ Fritz Schmidt	Aluminium	Overall approx. dimension: 595 mm by 434 mm by min. 1,5 mm thickness		Accepted
Grid Left side Right side	Schulmann	ABS	Overall approx. dimension: 162 mm by 125 mm by 20 mm by min. 1,25 mm thickness Flame Class: HB Class at min 1,5 mm thickness	IEC 60695	Accepted
Cover for DC-Connection SI	Various	Polycarbonate ESD	Overall approx. dimension: 204,6 mm by 94,6 mm by min. 3 mm thickness Temp. Class: 125 °C		Accepted
Strain relief 2 provided	Schlemmer	M32	Flame Class: IP 68; 100 °C; Polyamide 6; Gasket Neoprene	EN 60423	Accepted
Strain relief 2 provided	Schlemmer	M25	Flame Class: IP 68; 100 °C; Polyamide 6; Gasket Neoprene	EN 60423	Accepted
Strain relief	Schlemmer	M20	Flame Class: IP 68; 100 °C; Polyamide 6; Gasket Neoprene	EN 60423	EN 60423
Gasket Inside from Enclosure	Sonderhoff	K31-A 9021-2	Flame Class: UL 94 HF-1; 50 °C; min. 4 mm thickness	(QMFZ2)	cURus E217362
Support plate for SILED	+ Fritz Schmidt	Aluminium	Overall approx. dimension: 205 mm by 95 mm by min. 3 mm thickness		Accepted

Plate for control unit	Sabic	Polycarbonate Lexan 923A	Overall approx. dimension: 90,5 mm by 55 mm by 6 mm Flame Class: 94 V-0; 130 °C; min. 3 mm thickness	(QMFZ2)	URus E45329
Plug Sealing Clamp	Schlemmer	LDPE	Temp. Class: 90 °C		Accepted
Lock Nuts	Schlemmer	PG	Temp. Class: 120 °C		Accepted
Fan 2 provided	+ ebmPapst	LE 3312 U-026	12 V; 0,3 A; 75 °C Wire: AWG 22; TR 64; striped and tinned	(GPWV2)	cURus E38324
Internal wire for Fan	+ REI	Style 3271	600 Va.c.; 750 Vd.c.; AWG 24; 125 °C	(AVLV2)	cURus E108485
Internal wire for Current Sensor	+ Omerin	Style 3289	600 Va.c.; 750 Vd.c.; 150 °C; 0,5 mm ²	(AVLV2)	cURus E101965
Internal wire for AST-WR	3M	3659 Series	VW-1; Style 20267; 105 °C	(OPTZ)	ULus E118773
Tubing for internal wiring 4 provided	Hellermann	TF21-4.8/2.4	600 V; VW-1; 125 °C; min. 2,4 mm thickness Dielectric strength: 37k V	(YDPU2)	URus E143529
Inductor with integrated current Transformer	dtw	1650PTB2230	Rating: Isolation choke: 120 µH Supply Voltage: 26 V Output Voltage: 230 V/1650 VA Dielectric strength: 4000 Va.c. Amb. Temp.: 60 °C	EN 61558-1 EN 61558-2-4	Accepted
GEMINI-AST Board					
PCB GEMINI-AST	+ OMR	13	Overall approx. dimension: 360,5 mm by 268,5 mm by min. 1,9 mm thickness Flame Class: 94 V-0; 105 °C	(ZPMV2)	cURus E79991
Connector (X201)	+ Wago	2716-204	600 V; 65 A; AWG 16-6 Flame Class: 94 V-0; 105 °C	(XCFR2)	cURus E45172
Capacitor (C201)	+ Kemet	PHE840ER	300 Va.c.; 4,7 µF; 105 °C; X2	(FOKY2) IEC 60348-17	cURus E100117 VDE

Current Sensor (U202)	Sensitec	CMS2050	Closed type construction with overall approx. dimension: 35 mm by 7,3 mm by 23 mm Primary: 50 A Secondary: 2,5 V Isolation Voltage: 3,5 kV Amb. Temp.: 85 °C	(NMTR2)	cURus E251279
Capacitor (C206) Line to PE	+ Kemet	R.41	250 Va.c.; 100 nF; 110 °C; Y2	(FOWX2) IEC 60384-14	cURus E97797
Capacitor (C208) Line to PE	+ Vishay	MKP 338 6	300 Va.c.; 100 nF; 105 °C; Y2	(FOWX2) IEC 60384-14	cURus E354331 VDE
Capacitor (C209) Line to Neutral	+ Wima	MP3-Y2	250 Va.c.; 22 nF; 110 °C; Y2	(FOKY2) IEC 60384-14	URus E100438 VDE
Capacitor (C222) Line to Neutral	+ Xiamen Faratronic	MKP62 C42	250 Va.c.; 650 Vd.c.; 680 nF; 110 °C; X2	(FOKY2) IEC 60384-14	cURus E186662
Inductor (L204)	Epcos	B82726S2363N04 1	Open type construction with overall approx. dimension: 52 mm by 32 mm Rating: 2x1,0 mH; 36 A Core: Ferrite Coil: Enameled copper magnet wire wound on Core Tubing wiring: Polyester THEIC + Polyamidimid 200 °C at IEC 317-13/IEC 172		Accepted
Inductor (L204) Insulation Ring core	+ Akzo Nobel	Resicoat EL	Flame Class: 94 V-0; 105 °C; min. 0,1 mm thickness; Insulation Class B	(OCDT2)	cURus E214934
Inductor (L204) Insulation Ring core	+ Epcos	EJ 040 D	Flame Class: 94 V-0; min. 0,1 mm thickness; Insulation Class B	(OCDT2)	URus E194412
Inductor (L204) Insulation Tape	H-Old S P A	Nomex	Temp. Class: 155 °C	(OANZ2)	URus E178430
Inductor (L204) Foil	Dupont	Mylar A	Flame Class: VTM-2; 105 °C; min. 0,036 mm thickness	(QMFZ2)	cURus E93687
Inductor (L204) Base plate und Spacer	+ Sabic	Lexan 500R	Flame Class: 94 V-0; 80 °C; 1,1 mm thickness	(QMFZ2)	cURus E45329

Inductor (L204) Base plate und Spacer	+ Bayer	Makrolon 9415 Z	Flame Class: 94 V-0; 125 °C; min. 1,5 mm thickness; Insulation Class B	(QMFZ2)	cURus E41613
Capacitor (C222) Line to Neutral	+ Xiamen	MKP62 C42	275 Va.c.; 330 nF; 110 °C; X2	(FOWX2) IEC 60384-14	cURus E186600 VDE
Capacitor (C223, C224) Line to Neutral	+ Epcos	B3202	300 Va.c.; 33 nF 110 °C; Y2	(FOKY2) IEC 60384-14	cURus E157153 VDE
Capacitor (C228, C230) Line to Neutral	+ Epcos	B32021	300 Va.c.; 1500 Vd.c.; 22 nF; 110.°C; Y2	(FOKY2) IEC 60384-14	cURus E157153 VDE
Current Transformer (L206)	LEM	LAH 100-P	Closed type construction with overall approx. dimension: 33,3 mm by 11,5 mm by 21 mm Rating: Primary: 100 A Output: 50 mA Turns ratio: 1 : 2000 Isolation Voltage: 5 kV Amb. Op. Temp.: 85 °C	(NMTR2)	cURus E189713
Relay (K201, K202)	Zettler	AZSR250-2AE-9D	Contact: 250 Va.c.; 50 A Coil: 9Vdc Dielectric strength: 5000 Vrms Op. Temp.: 85 °C	(NLDX2) EN 60730-1 EN 60335-1	cURus E44211 VDE
Connector (X211, X241)	+ Wago	2716-202	600 V; 65 A; AWG 16-6 Flame Class: 94 V-0; 105 °C	(XCFR2)	cURus E45172
Connector (X212)	+ Wago	2716-203	600 V; 65 A; AWG 16-6 Flame Class: 94 V-0; 105 °C	(XCFR2)	cURus E45172
PTC Fuse (F301, F302)	Bourns	MF-RX135/72	72 V; 1,35 A; 85 °C	(XGPU2)	URus E174545
Thermo paste between F301, F302 and C1509	Assmann	Non-silicon- thermal- compound	Temp. Class: 150 °C Dielectric strength: 40 kV		Accepted
Transistor (V1104)	+ Fairchild	FQD7N10LTM	100 V; 5,8 A; 350 mOhm; Op. Temp. 150 °C		Accepted

Inductor (L1101)	XFMRS	XFSMD4 Series	Open type construction with overall approx. dimension: 18 mm by 15 mm by 7 mm Rating: 220 µH; 1,2 A Core: Ferrite Coil: Enameled copper Magnet wire Bobbin: Flame Class: 94 V-0		Accepted
Inductor (L1101) Insulation System	XFMRS	X155	Temp. Class: 155 °C; Class F	(OBJY2)	URus E151556
Non-Optical Isolator (U1101, U1201, U1202)	Analog Devices	ADuM1201CRZ-RL7	Rated Isolation Voltage min. 2500 Va.c. Op. Temp. 105 °C	(FPPT2)	URus E214100
Relay (K1201, K1202)	Tyco	V23092-A1005-A201	Contact: 250 Va.c.; 6 A Coil: 5 Vd.c. Amb. Temp.: 85 °C	(NLDX2) IEC 60664-1	cURus E214025
Connector (X1311, X1319)	Phoenix	MSTBVA 2,5/4-G-5,08	300 V; 12 A; 105 °C	(XCFR2)	cURus E60425
Connector (X1312, X1317)	Phoenix	MSTBVA 2,5/3-G-5,08	300 V; 12 A; 105 °C	(XCFR2)	cURus E60425
Capacitor Electrolytic	+ Panasonic	ECA2AM470	100 Vd.c.; 47 µF; 85 °C		Accepted
Capacitor (C1507, C1509)	+ Epcos	B81130C1225M	275Vac; 2,2µF; 100°C; X2	(FOKY2) IEC 60384-14	cURus E157153 VDE
Capacitor (C1701) Electrolytic	+ Matsushita	CE Series	100 V; 470 µF; 105 °C		Accepted
Transistor (V1704)	+ International Rectifier	IRFR18N15DPbF	150 V; 18 A; 110 W; 175 °C		Accepted



Transformer (T1701)	Lasslop	UES750	Open Type construction with overall approx. dimension: 22 mm by 21,3 mm by 17 mm Rating: 146 µH Core: Ferrite Coil: Enameled copper Magnet wire wound on Bobbin Temp. Class. 130 °C; Class B Insulation System: 105 °C; Class B at UL 1446	IEC 60068-2-20	Accepted
SIWRS-11 Board					
PCB SIWRS-11 Board	+ Schweizer AG	13	Overall approx. dimension: 190 mm by 160 mm by 3 mm thickness Mounted to Aluminum Heat sink overall approx. dimension: 310 mm by 60 mm by 14,5 mm Flame Class: 94 V-0; 130 °C	(ZPMV2)	URus E51432
Insulation Foil between SIWRS-11 Board and Heat sink	+ Kunze	KU-CG20/AV	Overall approx. dimension: 215 mm by 75 mm by min. 0,2 mm thickness Flame Class: 94 V-0; 150 °C	(QMFZ2)	cURus E337894
Capacitor (C201, C202, C203, C204, C205, C206, C207, C208, C209, C210, C211) Electrolytic Bulk	+ Sic-Safco	Snapsic 125	63 Vd.c.; 2700 µF; 125 °C	IEC 60384-4	VDE
Transistor (V312, V313, V316, V317, V322, V323, , V326, V327, V332, V333, V334, V337, V342, V343, V346, V347)	+ Int. Rec.	IRF2907ZSBF	75 V; 170 A; 4,5 mOhm; 175 °C		Accepted
Connector (X251, X252)	Wago	2716-102	300 V; 55 A; 105 °C	(XCFR2)	cURus E45172
SILED-14 Board					

PCB SILED-14 Board	+ GREULE GmbH	FR4	Overall approx. dimension: 140 mm by 56 mm by min. 1,8 mm thickness Flame Class: 94 V-0; 130 °C	(ZPMV2)	cURus E79887
SIBFS33-14 Board					
PCB SIBFS33-14 Board	+ Ruwel	U4	Overall approx. dimension: 104 mm by 80 mm by min. 1,7 mm thickness Flame Class: 94 V-0; 130 °C	(ZPMV2)	cURus E48403
SIMCMOD Board					
PCB SIMCMOD Board	+ GGP- Schaltungen	868	Overall approx. dimension: 50 mm by 33 mm by min. 2 mm thickness Flame Class: 94 V-0; 130 °C	(ZPMV2)	cURus E116573
SI485MOD Board					
PCB SI485MOD Board	+ GGP- Schaltungen	868	Overall approx. dimension: 50 mm by 33 mm by min. 2 mm thickness Flame Class: 94 V-0; 130 °C	(ZPMV2)	cURus E116573
SWDMSI Board					
PCB SWDMSI Board	KSG	ML 1	Overall approx. dimension: 85 mm by 68 mm by min. 1,6 mm thickness Flame Class: 94 V-0; 125 °C	(ZPMV2)	cURus E143060
Capacitor (C510)	Vishay	338 6 MKP	300 V; 1 nF; 105 °C; Y2	(FOWX2)	cURus 354331
Transformer (N500)	Würth	7490140112	Closed type construction with overall approx. dimension: 15 mm by 24 mm by 10 mm Rating: 350 µH; 100 mVa.c.; 8 mAd.c. Dielectric strength: 7200 Vrms Turns ratio: (1-3) : (16-14) (6-8) : (11-9) Op. Temp.: 85 °C	(NWGQ2)	cURus E205930



Comments:

- 1) an asterisk indicates a mark which assures the agreed level of surveillance
- 2) + means, that component from other vendor and other model number, but with the same rating and equivalent approvals are accepted.

4.1.3	Creepage distances and clearance distances for appliances					P
Steady force test						
2N	For bare conductors and for uninsulated capillary tubes of thermostats and similar devices					P
30N	Enclosure contacts bare parts at hazardous voltage?					P
Non PCB						
Clearance and creepage distance	Up (V)	U r.m.s. (V)	required cl (mm)	cl (mm)	required dcr (mm)	dcr (mm)
AC to earth (basic)	326	230	2,5	6,4	3,0	6,4
AC to DC (reinforced)	326	230	6,0	6,4	6,0	6,4
AC to USER* (reinforced)	326	230	6,0	6,4	6,0	6,4
PCB 'SIWRS-11'						
Clearance and creepage distance	Up (V)	U r.m.s. (V)	required cl (mm)	cl (mm)	required dcr (mm)	dcr (mm)
Only DC and USER* circuits present which are limited to SELV circuits.						
PCB 'GEMINI-AST-15'						
Clearance and creepage distance	Up (V)	U r.m.s. (V)	required cl (mm)	cl (mm)	required dcr (mm)	dcr (mm)
AC to earth (basic)	326	230	2,5	6,4	3,0	6,4
AC to DC (reinforced)	326	230	6,0	6,4	6,0	6,4
AC to USER* (reinforced)	326	230	6,0	6,4	6,0	6,4
Note:						
* USER is directly connected to DC. Both circuit types provide SELV limits.						

Block diagram:

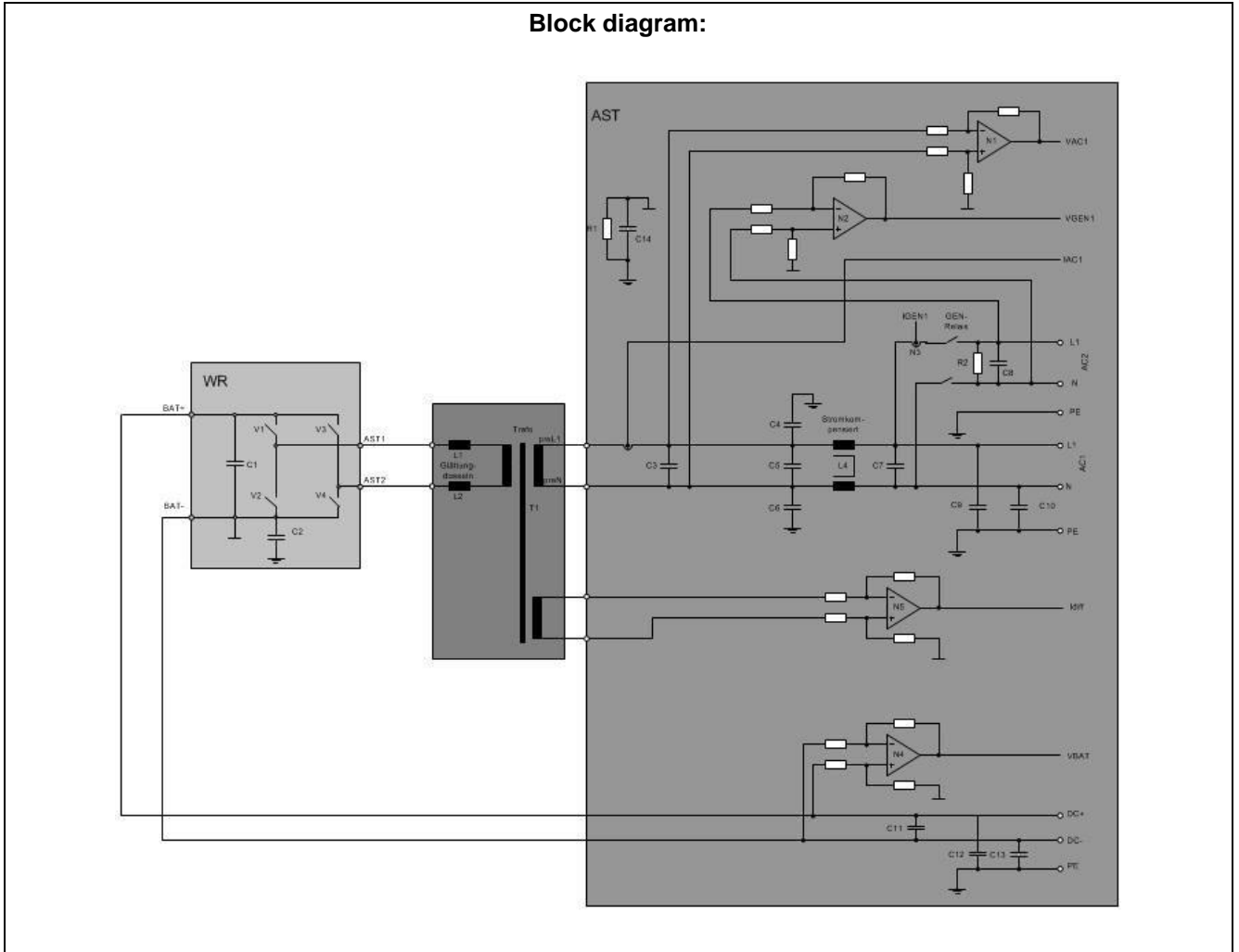

Layout top layer: PCB 'GEMINI-AST-15'

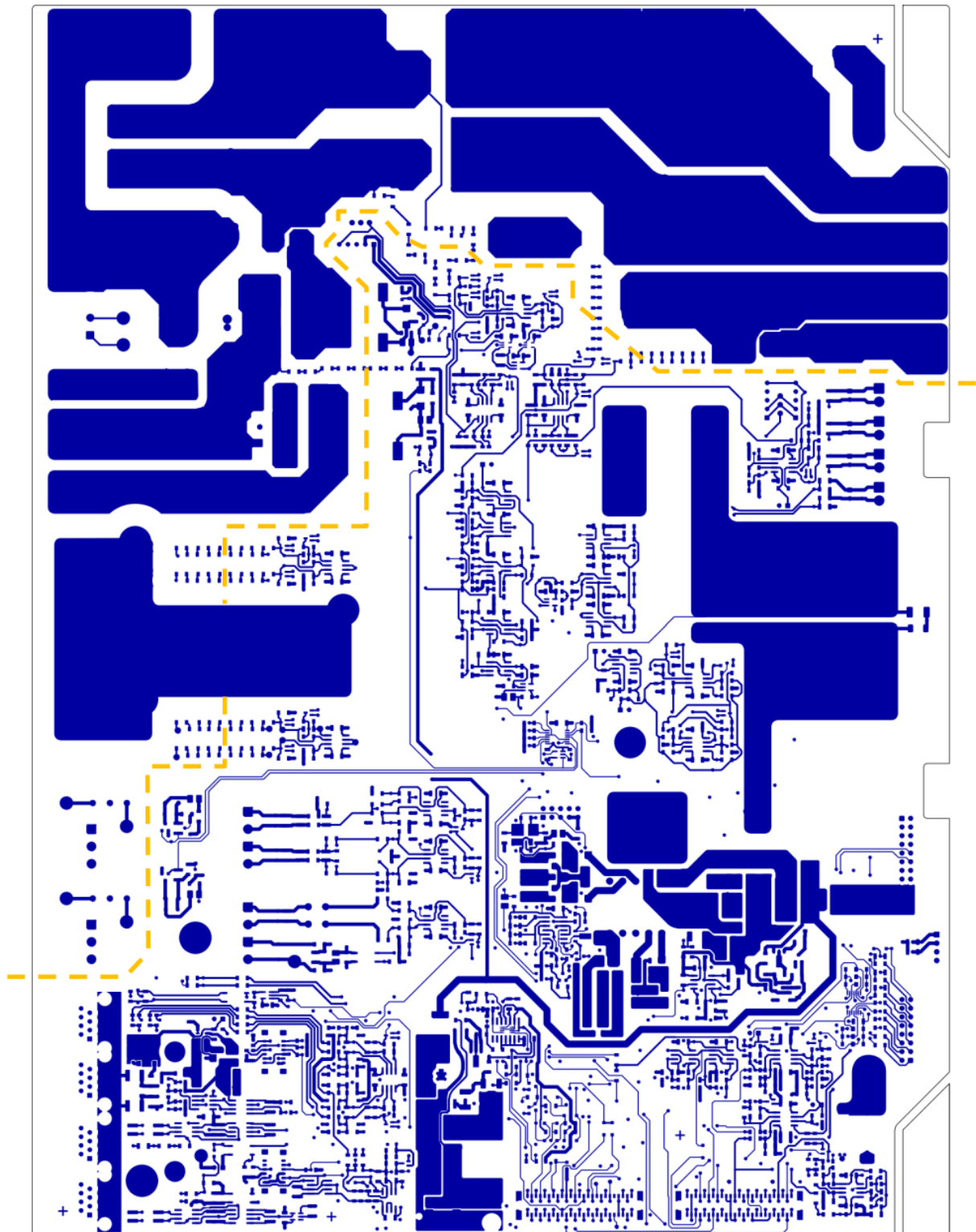

Layout bottom layer: PCB 'GEMINI-AST-15'

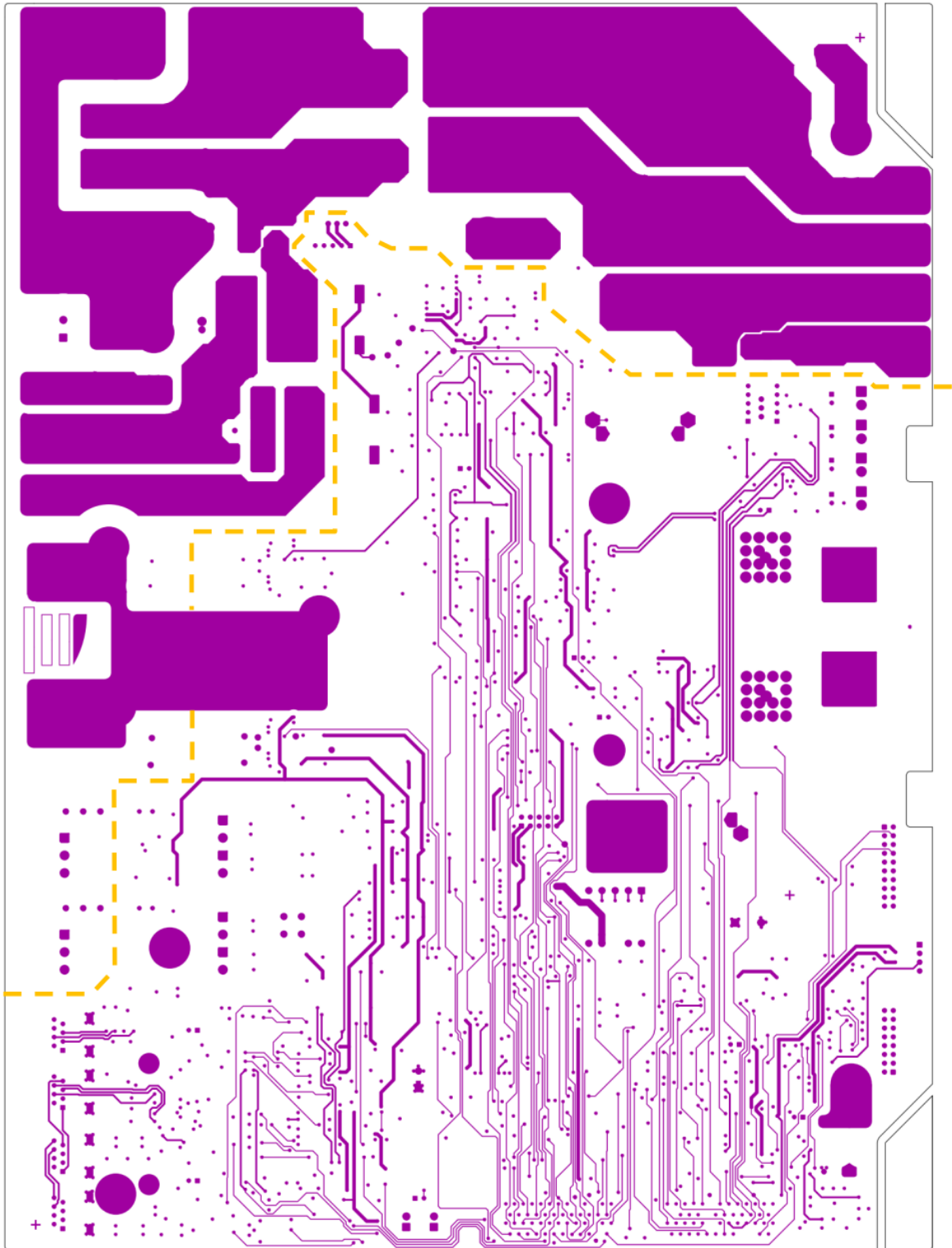

8.3.1	Insulation resistance Testing			P
A 500Vdc voltage was applied to the two locations. The current flowing was measured and the resistance was calculated.				
Location (from to)	Insulation type	Potential used	Insulation resistance	
AC to PE	Basic	500Vdc	1,1MΩ	
AC to USER	Reinforced/supplementary	500Vdc	1,9MΩ*	
DC to USER	Reinforced/supplementary	500Vdc	1,9MΩ*	
Note: * Value was accepted because tests of clauses 8.3.2 and 8.4 were passed.				

8.3.2	TABLE: Leakage current test		P
<i>The outputs were loaded to the rated value. The current measuring circuit according to Figure 4 of IEC 60990 was taken.</i>			
Star mains equipment			
Parts tested	Current (mA)	Comments	
Single Phase			
L → PE (enclosure)	14,7*	L → PE (enclosure)	
N → PE (enclosure)	4,19	N → PE (enclosure)	
<p>Note:</p> <p>* IEC62109-1 is the product standard for testing and evaluation of this type of equipment. According to that standard the maximum level for leakage current is defined at 3,5mA. For equipment exceeding this value several additional measures are accepted, e. g. the PE conductor provides a minimum conductor cross-section of at least 10mm² of copper, or provisions for a second PE terminal are provided together with adequate information within the installation instructions.</p> <p>Due to both measures were applied on the EUT the leakage current test was accepted also for the AS3100.</p>			



8.4	High voltage (electric strength)	P
test voltage applied between:	test voltage [V] a.c. / d.c.	breakdown Yes / No
AC to PE	1000Vac / 1420Vdc	No
AC to DC	2500Vac / 3540Vdc	No
AC to USER	2500Vac / 3540Vdc	No
Note: If a defect occurred during abnormal operation (8.15), the high voltage test was applied to assure that there is no hazard to the user.		

8.5	Test of earthing connection			P
Using a maximum 12 Vac power source, a current of 1,5 times rated current or 25A (whichever is greater) is passed between the equipment earthing terminal and the part in the equipment that is required by 8.5 to be earthed listed below. The voltage drop from the earthing terminal to the accessible metal part required to be earthed was recorded and the resistance was calculated. The resistance shall not exceed 0,1Ω.				
Accessible conductive part	Test current in [A _{DC}]	Measured Voltage in [V]	Calculated Resistance in [Ω]	
PE – terminal to enclosure cover	39,5	0,563	14,3	
PE – terminal to enclosure heatsink	39,8	0,571	14,3	
PE – terminal to enclosure side	40,0	0,541	13,5	



8.6	Cord anchorage			P
The cord is subjected 25 times to a steady pull, each time for duration of 1s.				
Force value:				
	m<1kg	30N	0,1Nm	
	1kg<m<4kg	60N	0,25Nm	
	m>4kg	100N	0,35Nm	
Test	Condition	Verdict	Comment	
Power supply cord damaged ?	100N	P	No damage.	
Longitudinal displacement:	0,95mm	P	Max. 2mm	

8.7	Test for screw threads and fixings			P
<p>Screwed components shall be tightened and loosened in a steady and uniform manner the following number of times:</p> <ul style="list-style-type: none"> a) where it operates in a thread in metal b) where it operates in a thread in insulating material <p>Torque dependent on the diameter, see 8.7.2</p>				
Tested screw/location		Condition (a or b)	Verdict	Comment (torque)
Screws for mounting the enclosure cover to the enclosure for connection of the AC wiring terminals.		a)	P	2,5Nm*
<p>Note:</p> <p>* Worst case value was applied.</p>				

8.8	Mechanical strength test	P
Equipment shall be subjected to blows, with an impact energy of 0,5 +/- 0,05Nm, by the impact-test apparatus, see clause 8.8.2		
Part	Observation	
Enclosure cover	No damage of the enclosure.	
Enclosure side	No damage of the enclosure.	
Enclosure back	No damage of the enclosure.	
<p>Comment:</p> <p>After the test, the sample shall show no damage within the meaning of this Specification; in particular, live parts shall not have become exposed. In case of doubt, supplementary insulation is subjected to an electric strength test as specified in Clause 8.4.3.</p>		



8.10	Standard test finger and protective impedance	P
8.10.3	Method of use (test finger)	P
Part	Observation	Verdict
Enclosure overall.	No contact to live parts or non-current carrying conductive parts possible.	P
Note:		

8.11	Temperature measurement		P
	Test voltage (Vdc)	60	—
	Test current (Idc)	24,5	—
	Test voltage (Vac)	230	—
	Test current (Iac)	6,1	—
	t _{amb1} (°C).....	60	—
	t _{amb2} (°C).....	60	—
maximum temperature T of part/at::		T (°C)	T _{max} (°C)
1.	WR ELKO1	70,83	105
2.	WR ELKO2	71,26	105
3.	N_ Trafo	68,17	130
4.	L_ Trafo	70,21	130
5.	Display	62,51	70
6.	SIBFS DSP	90,18	
7.	X201	67,01	105
8.	C202	66,51	125
9.	C1507	67,48	100
10.	T1701	78,75	105
11.	L204	65,96	80
12.	K202_Amb	66,15	85
13.	X211	64,37	105
14.	WR_MOS	71,77	105
15.	SWDMSI Übertrager	66,13	
16.	SWDMSI CPU	73,10	
17.	Housing_Out1	64,53	70
18.	Housing_Out2	60,79	70
19.	Housing_Out3	60,57	70
20.	Housing_Out4	60,88	70
21.	Trafo_Top	60,68	130
22.	Klemme Teddy WR	69,56	
23.	HsTmp	74,55	
24.	TrfTmp	86,31	
<p>The above temperatures are recorded at t_{amb1}. The values measured are subtracted with t_{amb1} and t_{amb2} (°C) added. Therefore above measured temperatures are the absolute temperatures in °C at maximum ambient. The printed circuit board is rated 105 °C:</p>			



8.13	Test of marking	P
Nameplates, transfers and paintings used to provide the information required in accordance with Clause 7.1 shall be checked by inspection and by rubbing by hand for 15 s with a piece of cloth soaked with water and again with a piece of cloth soaked with petroleum spirit.		
Requirement		Observation
Legible?		Yes
Marking easily removable?		No
Curling?		No

8.15	Abnormal operation							P
Component No.	Fault	test condition		Test time	fuse No. (AC)	fault condition		Result
		AC	DC			AC	DC	
Transistor (V311)	Short	230V 4,0A	42V 25,7A	10min	32A	230V 0A	42V 0A	Unit switched off immediately. Display indicates: "BatVtgMin" No hazard. No fire. No defect.
Transistor gate (V311)	Open	230V 4,0A	42V 25,7A	10min	32A	230V 0A	42V 0A	Unit switched off immediately. No hazard. No fire. No defect.
IGBT (V348)	Short	230V 14,1A	58V 56,2A	10min	16A	230V 0A	58V 0A	Unit switched off immediately. SRC reboots, No hazard. No fire. No defect.
Temperature sensor On PCB	Defect (R703)	230V 4,0A	48V 22,5A	10min	32A	230V 4,0A	48V 22,5A	Unit did not start. No hazard. No fire. No defect.
Primary current sensor	Disabled (X802, Pin 3 to Pin 4 short)	230V 4,0A	48V 23,6A	10min	32A	230V 4,0A	48V 23,6A	No effect on function. No hazard. No fire. No defect.
Temperature sensor Transformer	Defect (X602, Pin 1 to Pin 2 short)	230V 4,0A	48V 23,6A	10min	32A	230V 4,0A	48V 23,6A	No effect on function. No hazard. No fire. No defect.
Temperature sensor Smoothing choke	Defect (X604, Pin 1 to Pin 2 short)	230V 4,0A	48V 23,6A	10min	32A	230V 4,0A	48V 23,6A	No effect on function. No hazard. No fire. No defect.
Temperature sensor Smoothing choke	Defect (X606, Pin 1 to Pin 2 short)	230V 4,0A	48V 23,6A	10min	32A	230V 4,0A	48V 23,6A	No effect on function. No hazard. No fire. No defect.
Current sensor (generator) (L206)	Short	230V 14,1A	58V 56,2A	10min	16A	230V 14,1A	58V 56,2A	No effect on function, No hazard, No defect , No fire
Voltage measurement between Transformer and choke	Defect (C707 short)	230V 4,0A	48V 23,6A	10min	32A	230V 0A	48V 0A	Unit switched off immediately. Display indicated: "VtgOnAc1Det". No hazard. No fire. No defect.
Voltage measurement AC1	Defect (C401 short)	230V 4,0A	48V 23,6A	10min	32A	230V 4,0A	48V 23,6A	No effect on function. No hazard. No fire. No defect.
Voltage measurement AC2 (Gen)	Defect (C405 short)	230V 4,0A	48V 23,6A	10min	32A	230V 4,0A	48V 23,6A	No effect on function. No hazard. No fire. No defect.

Voltage measurement NTT (Gen)	Defect (C501 short)	230V 4,0A	48V 23,6A	10min	32A	230V 4,0A	48V 23,6A	No effect on function. No hazard. No fire. No defect.
Voltage measurement Battery	Defect (C305 short)	230V 4,0A	48V 23,6A	10min	32A	230V 0A	48V 0A	Unit switched off immediately. Display indicated: "BatVtgMax". No hazard. No fire. No defect.
Battery current measurement	Defect Short (R311)	230V 4,0A	48V 23,6A	10min	32A	230V 4,0A	48V 23,6A	No effect on function. No hazard. No fire. No defect.
Current monitoring AC pri and sec	Defect Short (C810)	230V 4,0A	48V 23,4A	10min	32A	230V 4,0A	48V 23,4A	No effect on function. No hazard. No fire. No defect.
Current measurement sec	Defect (Short C801)	230V 4,0A	48V 23,4A	10min	32A	230V 4,0A	48V 23,4A	No effect on function. No hazard. No fire. No defect.
Fan control (V1104)	Short	230V 4,0A	48V 23,4A	10min	32A	230V 4,0A	48V 23,4A	No effect on function. No hazard. No fire. No defect.
Primary switch of auxiliary supply	V1704 short	230V 4,0A	50V 21,5A	10min	32A	230V 0A	50V 0A	Unit switched off immediately. No temperature rise on transformer T1701. No hazard. No fire. No defect.
Transformer short circuit tests								
T1701	Pin1 to Pin2 short	230V 4,0A	50V 21,5A	10min	32A	230V 0A	50V 0A	Unit switched off immediately. No temperature rise on transformer T1701. No hazard. No fire. No defect.
T1701	Pin5 to Pin6 short	230V 4,0A	50V 21,5A	10min	32A	230V 4,0A	50V 21,5A	No effect on function. No hazard. No fire. No defect.
T1701	Pin3 to Pin15 short	230V 4,0A	50V 21,5A	10min	32A	230V 0A	50V 0A	Unit switched off immediately. No temperature rise on transformer T1701. No hazard. No fire. No defect.
T1701	Pin9 to Pin10 short	230V 4,0A	50V 21,5A	10min	32A	230V 0A	50V 0A	Unit switched off immediately. No temperature rise on transformer T1701. No hazard. No fire. No defect.
Output overload								

T1701	Pin5 to Pin6 short	230V 4,0A	50V 21,5A	3h	32A	230V 4,0A	50V 21,5A	A maximum load of 1,47W was possible to apply on transformer T1701 before the inverter switched off. At this overload condition a temperature on T1701 of 62,5°C @ 23°C ambient temperature was measured. No hazard. No fire. No defect.
T1701	Pin3 to Pin15 short	230V 4,0A	50V 21,5A	3h	32A	230V 4,0A	50V 21,5A	A maximum load of 0,022W was possible to apply on transformer T1701 before the inverter switched off. At this overload condition a temperature on T1701 of 61,3°C @ 23°C ambient temperature was measured. No hazard. No fire. No defect.
T1701	Pin9 to Pin10 short	230V 4,0A	50V 21,5A	3h	32A	230V 4,0A	50V 21,5A	A maximum load of 1 W was possible to apply on transformer T1701 before the inverter switched off. At this overload condition a temperature on T1701 of 71,5°C @ 23°C ambient temperature was measured. No hazard. No fire. No defect.
Reverse DC connection								
Input + and -	Mismatch	230V 0A	48V 0A	10min	32A	230V 0A	48V 0A	Unit did not start. No hazard. No fire. No defect.
PWB short circuit test – verify functional insulation								
AST1 to AST2	Short	230V 4,0A	48V 23,5A	10min	32A	230V 0A	48V 0	Unit switched off immediately. No hazard. No fire. No defect.
L transformer to N transformer	Short (X201, Pin 1 to Pin 4 short)	230V 4,0A	48V 23,6A	10min	32A	230V 0A	48V 0	Unit switched off immediately. Unit tried to restart without result -> Output still off. No hazard. No fire. No defect.
L choke to N choke	Short (X201, Pin 2 to Pin 4 short)	230V 4,0A	48V 23,6A	10min	32A	230V 0A	48V 0	Unit switched off immediately. Sunny remote control re-booted, but no reconnection. No hazard. No fire. No defect.



Capacitor C222	Short	230V 4,0A	48V 23,6A	10min	32A	230V 0A	48V 0	Unit switched off immediately. Sunny remote control re-booted, but no reconnection. No hazard. No fire. No defect.
L choke to N choke	Short (X201, Pin 3 to Pin 4 short)	230V 4,0A	48V 23,6A	10min	32A	230V 0A	48V 0	Unit switched off immediately. Sunny remote control re-booted, but no reconnection. No hazard. No fire. No defect.
Output shorts								
L to N, AC1	Short	230V 14,1A	58V 56,2A	10min	16A	230V 0A	58V 0A	3periods AC current rms and peak: $I_p = 26A$ $I_{rms} = 4,15A$
L to N, AC1	Short	230V 14,1A	58V 56,2A	10min	16A	230V 0A	58V 0A	3periods AC current rms and peak: $I_p = 62A$ $I_{rms} = 4,88A$
Note:								



B 2	Resistance to heat test		P
	allowed impression diameter (mm)	≤ 2 mm	—
Part	Test temperature °C	Impression diameter mm	
Inductance L204/L205 (base plate)	125	1,1	
Transformer T1701 (bobbin)	125	0,8	
Comment:			

B 3.3	Glow wire test						P
Part tested	Temperature [°C]	Flame height [cm]	Duration until flame t _i [s]	Duration of flame t _e [s]	Duration of flame t _a [s]	Result	
B1 Capacitor C210 (2700µF) b	750	-	-	-	30	P	
B1 Capacitor C209 (2700µF) o	750	-	-	-	30	P	
B1 Transistor XB800	750	-	-	-	30	P	
B1 Connector X707	850	-	-	-	30	P	
B1 beneath X707	750	-	-	-	30	P	
B1 Capacitor C425	750	-	-	-	30	P	
B1 Connector X700	850	0,5	1	2	30	P	
B1 IC V421	750	-	-	-	30	P	
B1 IC V425	750	-	-	-	30	P	
B1 Capacitor C423	750	-	-	-	30	P	
B1 Resistor R411	750	-	-	-	30	P	
B1 H501	750	-	-	-	30	P	
A1 Coil T1701	750	-	-	-	30	P	
A1 Capacitor C1509	750	1	1	5	30	P	
A1 Capacitor C1701	750	-	-	-	30	P	
Fuse F301	750	-	-	-	30	P	
A1 Capacitor C212	750	-	-	-	30	P	
A1 Capacitor C206	750	-	-	-	30	P	
IC-Housing L201	750	-	-	-	30	P	
Relay K1202	750	2	-	1	30	P	
Relay K202	850	-	-	-	30	P	
A1 Capacitor C1109	750	-	-	-	30	P	
IC V1213	750	-	-	-	30	P	
L206	750	0,5	-	1	30	P	
A1 Capacitor C202	750	-	-	-	30	P	
Coil L205 Cover	750	-	-	-	30	P	
Coil L205	750	4	-	5	30	P	
AC-Connector X221	850	-	-	-	30	P	
AC-Connector X231	850	12	-	30	30	P	
Connector X1901	850	10	-	14	30	P	
Connector X902	850	0,5	2	3	30	P	
Connector X802	850	3	-	24	30	P	
Connector X1304	850	3	-	35	30	P	
Transformer L601	750	-	-	-	30	P	
Connector X1402	850	-	-	-	30	P	
IC D1102	750	-	-	-	30	P	
R2 Connector X705	850	-	-	-	30	P	



R2 Connector X700	850	-	-	-	30	P
R2 Connector X201	850	4	25	30	30	P

Note:

Only the mentioned components were tested in B3.3 exemplarily, but results apply to any occurrence of the identical component (same material).

B 3.4	Needle-flame test		P	
Part tested		Duration of flame t_b [s]	Application of flame t_a [s]	Result
Wiring from choke to AC		-	30	P
Wiring from AST-board to SIWR-board		-	30	P
Ribbon cable to display		-	30	P
<p>Comment:</p> <p>The test specimens were pre-conditioned in the laboratory environment. One sample of each specimen was tested. The needle-flame was applied to one point at each specimen. A wrapping tissue was used as burning indicator.</p> <p>The needle-flame test was conducted as consequential test to the glow-wire testing in B 3.3. Only the mentioned components were tested in B3.4 exemplarily, but results apply to any occurrence of the identical component (same material).</p>				

Annex No. 2

EMC Test Report

The following documents are extracts of the original EMC test reports which in full are stored at Bureau Veritas CPS Germany GmbH in Project folder 13TH0287.

Test report
EMC-Testing



SI4.4M

including SI3.0M

Accredited according to
DIN EN ISO/IEC 17025



Test document

SI4.4M

This report is based on the testreport-template:
 PB_Kopf_EMV_EN Version 10 from 12.06.2013
 DHC-Vision ID 780468 Editor: Berger Niels (Dr.)released by: Billy Akpebu

Revision History

Document-number SI4.4M	Edition and Revision type ¹⁾		Annotations	Author
-51:LE4713	1.0	A	First Edition	Rauch, Andreas

- ¹⁾
- A: First Edition or Modifications due to errors or improvements in the documentation
 - B: Modifications maintaining full and upward compatibility
 - C: Modifications limiting or excluding compatibility

Testet by	05.12.2013	Released by	05.12.2013
	 X Andreas Rauch Signiert von: Andreas Rauch		 X Authorized signatory Signiert von: Niels Berger

Test document

SI4.4M

Explanation of symbols used

In order to ensure comprehension of this test report please note the following explanations of the symbols used.



This symbol indicates an important comment.
For this reason read these sections carefully.



This symbol indicates an example.



This symbol indicates an opinion or an interpretation to circumstances.

Table of contents

1	Overview on results.....	6
1.1	Pictures of EUT	7
1.1	Emission.....	9
1.2	Immunity	10
2	Operating state and Test setup.....	11
3	Modification of EUT	15
4	Emission.....	16
4.1	Conducted emissions.....	16
4.1.1	Test requirements.....	16
4.1.2	Test setup	17
4.1.3	Test details.....	17
4.1.4	Conductive voltage and current emissions-overview: not grounded.....	18
4.1.5	Conductive voltage and current emissions-overview: Batterie Plus grounded	45
4.1.6	Conductive voltage and current emissions-overview: Batterie Minus grounded	72
4.1.7	Appendix: Photos.....	99
4.2	Radiated emission.....	100
4.2.1	Test requirements.....	100
4.2.2	Test setup	100
4.2.3	Test details.....	101
4.2.4	Radiated electric emissions-overview: not grounded	102
4.2.5	Radiated electric emissions-overview: Batterie Plus grounded.....	113
4.2.6	Radiated electric emissions-overview: Batterie Minus grounded.....	124
4.2.7	Appendix: Photos.....	132
5	Immunity.....	134
5.1	Test Surge.....	135
5.1.1	Test requirements.....	135
5.1.2	Test setup	135
5.1.3	Test Log.....	135
5.1.4	Appendix: Photos.....	141

Test document

SI4.4M

5.2	Test Power frequency magnetic field	143
5.2.1	Test requirements.....	143
5.2.2	Test setup	143
5.2.3	Test Log.....	143
5.2.4	Appendix: Photos.....	146
5.3	Test Voltage dips and interruptions.....	148
5.3.1	Test requirements.....	148
5.3.2	Test setup	148
5.3.3	Test Log.....	149
5.3.4	Appendix: Photos.....	151
5.4	Test Conducted RF disturbance.....	152
5.4.1	Test requirements.....	152
5.4.2	Test setup	152
5.4.3	Test Log.....	152
5.4.4	Appendix: Photos.....	156
5.5	Test Electrostatic discharge	157
5.5.1	Test requirements.....	157
5.5.2	Test setup	157
5.5.3	Test Log.....	158
5.5.4	Appendix: Photos.....	160
5.6	Test Radiated immunity.....	161
5.6.1	Test requirements.....	161
5.6.2	Test setup	161
5.6.3	Test Log.....	161
5.6.5	Appendix: Photos.....	192
5.7	Test Fast transient / burst.....	193
5.7.1	Test requirements.....	193
5.7.2	Test setup	193
5.7.3	Test Log.....	193
5.7.4	Appendix: Photos.....	196

1 Overview on results

Client:	Manufacturer:	Test department and site:
SMA Solar Technology AG	SMA Solar Technology AG	SMA Solar Technology AG
Sonnenallee 1	Sonnenallee 1	Sonnenallee 1
34266 Niestetal	34266 Niestetal	EMV- und Umweltlabor (EUL)
Immel, Daniel		34266 Niestetal / Germany
		Building 4

Order / job account:	390 / 860393
Project titel:	Sirius_2013-08-15
Test type / limits and requirements:	EN61000-6-2:2005 german version EN61000-6-3:2007+A1:2011 german version
Type of equipment tested:	Island inverter
Label of equipment:	SI4.4M, SI3.0M

Test specification:

Identification of the EUT: (equipment under test)

EUT number:	Serial number:	Hardware version:	Firmware version:	Remark:
1978	SI4.4M: 1262000025 Components: SIAST50-48S: 0000025 SIBFS33.BG1: 02725 SWDMSI-10.BG1: 002913 SIWRS-01: 0000024	SI4.4M: S02 Components: SIAST50-48S: R1 SIBFS33.BG1: A1 SWDMSI-10.BG1: R1 SIWRS-01: Q1	SI4.4M: 02.05.14.R SWDMSI-10.BG1: 01.01.06.R	
1976	SI4.4M: 1262000009 Components: SIAST50-48S: 0000009 SIBFS33.BG1: 02726 SWDMSI-10.BG1: 002912 SIWRS-01: 0000034	SI4.4M: S02 Components: SIAST50-48S: R1 SIBFS33.BG1: A1 SWDMSI-10.BG1: R1 SIWRS-01: Q1	SI4.4M: 02.05.14.R SWDMSI-10.BG1: 01.01.06.R	

Test document

SI4.4M

1.1 Pictures of EUT

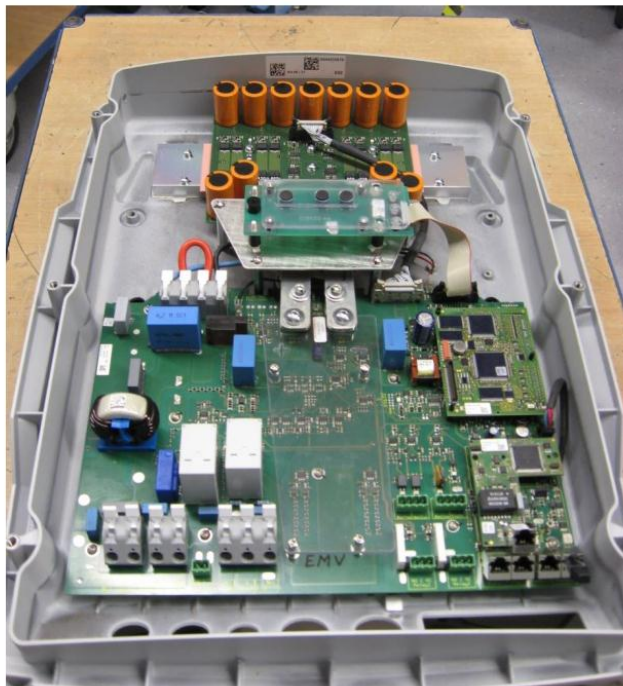

Test document

SI4.4M

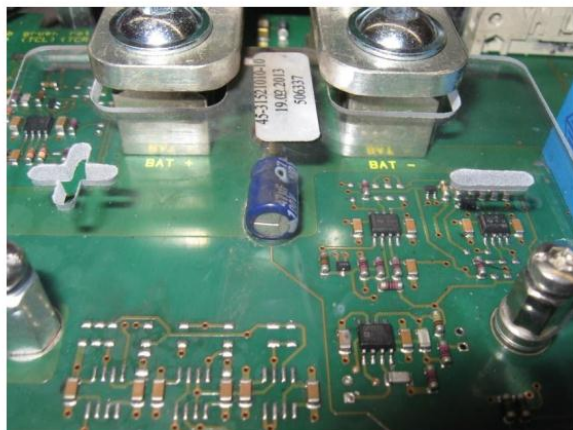

Important remarks

Topic	Description
Standards chosen:	Tested standards were chosen together with client (see above). Correct Standards needed for declaration of conformity and normative classification of EUT obtains to client.
Validity of test results:	The results listed in this test report apply for the EUT tested only. Any modification in mechanical construction, circuitry or components used will have an effect on the results. Duplication or Copies of any excerpts from this report is not allowed without a written approval of the test department.
Other standards:	Within this project no inquiry were made to point out further standards required for this type of equipment tested (e.g. ETSI-standard or similar). It is therefore the responsibility of the customer to point this out on his own.
Priority of other standards:	In case of testing according EN55024 please be advised, that there additional standards (e.g. ETSI harmonised standards), which cover the immunity requirements for telecommunication applications and must be preferred
Descriptions of test setup and test details:	„Norm“ means according standard „SMA“ means special requirements and evaluation

1.1 Emission

test and normative standard	equipment under test (EUT no.)	requirement	
		standard	additional
		modification / remarks	modification / remarks
Requirements according EN61000-6-3:2007+A1:2011			
Radiated emission according to: EN55016-2-3:2006	1976	passed	N/A
		1	N/A
Conducted emissions according to: EN55022:2010	1976	passed	N/A
		1	N/A
Conducted emissions according to: EN55016-2-1:2009	1976	passed	N/A
		1	N/A
test summary*		standard requirement / re- marks	additional requirement / re- marks
Requirements according EN61000-6-3:2007+A1:2011		passed	N/A

For all EN-standards used, the German version (DIN EN) was applied.

* regarding to all mentioned remarks.

1.2 Immunity

test and normative standard	equipment under Test (EUT no.)	requirement	
		standard	additional
		modification / remarks	modification / remarks
Requirements according EN61000-6-2:2005			
Fast transient / burst according to: EN61000-4-4:2004	1978	passed	passed
		1	1
Radiated immunity according to: EN61000-4-3:2002	1978	passed	passed
		1	1
Electrostatic discharge according to: EN61000-4-2:1995	1978	passed	failed
		1	1
Conducted RF disturbance according to: EN61000-4-6:2009-03	1978	passed	passed
		1	1
Voltage dips and interruptions according to: EN61000-4-11:2004	1978	passed	not tested
		1	1
Power frequency magnetic field according to: EN61000-4-8:1993	1978	passed	passed
		1	1
Surge according to: EN61000-4-5:1995	1978	passed	passed
		1	1
test summary*		standard requirement / remarks	additional requirement / remarks
Requirements according EN61000-6-2:2005		passed	failed

For all EN-standards used, the German version (DIN EN) was applied.

* regarding to all mentioned remarks.

Annex No. 3

IP Test Report



Königswinkel 10
32825 Blomberg
Telefon +49 5235 / 9500-0
Fax +49 5235 / 9500-10

Prüfbericht

Nr.: U143701D1

Prüflingsbezeichnung: SI3.0M-11 und Variante SI4.4M-11

Prüflabor
in den Bereichen
**"Sicherheit elektrischer Betriebsmittel und
Industrielle Niederspannungsgeräte
sowie Umweltprüfungen"**

akkreditiert von
DAkKS Deutsche Akkreditierungsstelle GmbH
nach DIN EN ISO/IEC 17025
unter der
Reg. Nr. D-PL-17186-01-03



Eine auszugsweise Vervielfältigung dieses Berichtes ist ohne schriftliche Genehmigung der Prüfstelle nicht gestattet. Die in dem Bericht aufgeführten Prüfergebnisse beziehen sich ausschließlich auf den unten näher bezeichneten Prüfgegenstand. Eine Übertragung auf andere Systeme oder Konfigurationen ist nicht zulässig.

Prüfstelle: PHOENIX TESTLAB GmbH
Königswinkel 10
D-32825 Blomberg

Auftraggeber: SMA Solar Technology AG
Sonnenallee 1
D-34266 Niestetal

Auftragsnummer: 14-113701

Art der Prüfung: IP-Schutzarten

Prüfgrundlagen: EN 60529:1991 + A1:2000 + A2:2013



Prüfgegenstand: SI3.0M-11 und Variante SI4.4M-11

Prüfling	Serial Nr.
1	SI3.0M-11

Die Variante SI4.4M-11 ist laut Hersteller mit dem gleichen Gehäuse und dem gleichen Trafo versehen.

Hersteller: SMA Solar Technology AG
Sonnenallee 1
D-34266 Niestetal

Eingangsdatum
des Prüflings: 07. Oktober 2014

Kunde bei Prüfung
durch folgende
Person(en) vertreten: Hr. Lisson (teilweise)

Ort der Prüfung: PHOENIX TESTLAB GmbH, Blomberg

Datum der Prüfung: 07. Oktober 2014 – 08. Oktober 2014



Prüfergebnis: Die Prüfanforderungen und Prüfbedingungen sind den nachfolgenden Seiten zu entnehmen.

Die Anforderungen aus den Prüfgrundlagen wurden durch den Prüfgegenstand **eingehalten**.

Blomberg, 09. Oktober 2014

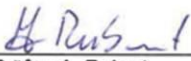
Prüfer: A. Rubart

Freigabe-Berechtigter: M. Zelt



Inhalt	Seite
1 Prüfanforderungen und Prüfbedingungen.....	6
1.1 IP-Schutzarten	6
2 Prüfablauf und Prüfergebnisse	9
2.1 Prüfablauf.....	9
2.2 Prüfergebnisse.....	10
2.2.1 Schutz gegen den Zugang zu gefährlichen Teilen und gegen feste Fremdkörper, bezeichnet durch die erste Kennziffer nach EN 60529.....	10
2.2.2 Schutz gegen Wasser, bezeichnet durch die zweite Kennziffer nach EN 60529.....	10
3 Messmittelliste	11
4 Bilder	12
5 Bilderverzeichnis	15



1 Prüfanforderungen und Prüfbedingungen

1.1 IP-Schutzarten

Basis: DIN EN 60529: 1991 + A1:2000 + A2:2013

Der IP-Code stellt ein System zur Einteilung der Schutzarten durch die Gehäuse von elektrischen Betriebsmitteln zur Verfügung. Der Zweck dieser Norm ist es, folgendes festzulegen:

- Schutz von Personen gegen den Zugang zu gefährlichen Teilen innerhalb des Gehäuses (1. Kennziffer);
- Schutz des Betriebsmittels innerhalb des Gehäuses gegen Eindringen von festen Fremdkörpern (1. Kennziffer)
- Schutz des Betriebsmittels innerhalb des Gehäuses gegen schädliche Einwirkungen durch das Eindringen von Wasser (2. Kennziffer).

Der Aufbau des IP-Codes ist nachfolgend dargestellt:

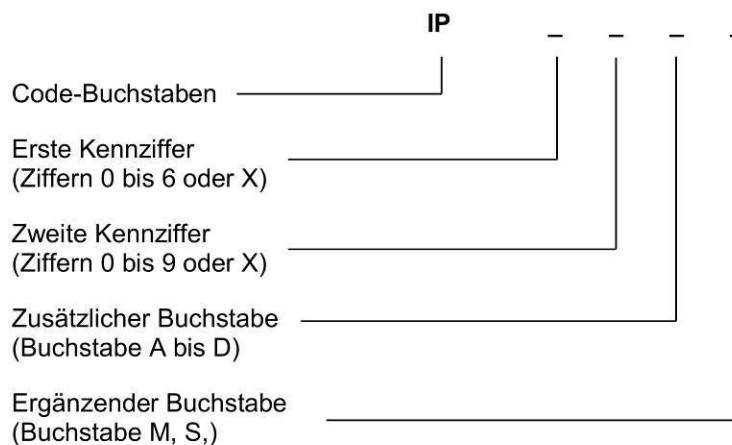

Nicht angegebene Kennziffern sind durch den Buchstaben „X“ zu ersetzen. Zusätzliche Buchstaben und/oder ergänzende Buchstaben dürfen ersatzlos weggelassen werden.

Tabelle 1: Bestandteile des IP-Codes nach DIN EN 60529 und ihre Bedeutung

Bestandteil	Ziffern oder Buchstaben	Bedeutung für den Schutz des Betriebsmittels	Bedeutung für den Schutz von Personen
Code Buchstaben	IP	-	-
		<i>Gegen Eindringen von festen Fremdkörpern</i>	<i>Gegen Zugang zu gefährlichen Teilen mit</i>
Erste Kennziffer	0	nicht geschützt	nicht geschützt
	1	≥ 50 mm Durchmesser	Handrücken
	2	≥ 12,5 mm Durchmesser	Finger
	3	≥ 2,5 mm Durchmesser	Werkzeug
	4	≥ 1,0 mm Durchmesser	Draht
	5	staubgeschützt	Draht
	6	staubdicht	Draht
		<i>Gegen Eindringen von Wasser mit schädlichen Wirkungen</i>	
Zweite Kennziffer	0	nicht geschützt	
	1	senkrecht Tropfen	
	2	Tropfen (15° Neigung)	
	3	Sprühwasser	
	4	Spritzwasser	
	5	Strahlwasser	
	6	starkes Strahlwasser	
	7	zeitweiliges Untertauchen	
	8	dauerndes Untertauchen	
	9	hoher Druck mit hoher Strahlwassertemperatur	



Schärfegrad der Prüfung:

Prüfling	Schutzart
1	IP 5X
1	IP X5

Tabelle 2: Spezifikation der IP 5X Prüfung

Prüfmittel:	Staubkammer
Unterdruck:	< 20 mbar
Prüfstaub:	Talkum
Prüfdauer:	8 h

Tabelle 3: Spezifikation der IP X5 Prüfung

Durchflussmenge:	12,5 l/min
Abstand zum Prüfling:	2,5 – 3 m
Wassertemperatur:	$(20 \pm 5) \text{ } ^\circ\text{C}$, $T_{\text{Wasser}} = T_{\text{Prüfling}} \pm 5 \text{ } ^\circ\text{C}$
Prüfdauer:	3 min



2 Prüfablauf und Prüfergebnisse

2.1 Prüfablauf

Der Prüfling wurde vom Auftraggeber vor den Prüfungen modifiziert (siehe Bild 6). Es wurde eine Rolle OBO Bettermann Dichtkitt um und über die Kabeleinführung verteilt.

Bei der IP 5X Prüfung wird der Prüfling in der Staubkammer positioniert und der Unterdruck in den Gehäusen durch eine Vakuumpumpe auf nicht mehr als 20 mbar gebracht.

Als Prüfstaub dient Talkumpuder mit einer definierten Korngröße, das über eine Staubumlaufpumpe in der Schwebelage gehalten wird.

Die Menge des Prüfstaubes muss mindestens 2 kg je m³ betragen.

Die Prüfdauer beträgt 8 h.

Nach Ablauf der Prüfzeit wird der Prüfling auf Dichtigkeit überprüft.

Bei der IP X5 Prüfung wird der Prüfling in 3 Meter Entfernung von der Strahldüse auf einem Tisch positioniert.

Mit der definierten Wassermenge von 12,5 l/min, Einstellung über einen Durchflussmesser, werden die Prüflinge in einem Abstand von 2,5 m bis 3 m gleichmäßig für 3 Minuten bespritzt.

Die Wassertemperatur weicht um nicht mehr als 5 K von der Temperatur des Prüflings ab.

Nach Ablauf der Prüfzeit wird der Prüfling auf Dichtigkeit überprüft.



2.2 Prüfergebnisse

Legende: P Pass / Bestanden
F Fail / Nicht Bestanden

2.2.1 Schutz gegen den Zugang zu gefährlichen Teilen und gegen feste Fremdkörper, bezeichnet durch die erste Kennziffer nach EN 60529

Erste Kennziffer	Schutz gegen den Zugang zu gefährlichen Teilen	Schutz gegen das Eindringen von festen Fremdkörpern	Status
5	Der Prüfdraht von 1,0 mm Durchmesser darf nicht eindringen, und ausreichender Abstand muß gehalten werden	Staubkammer, Unterdruck: 20 mbar Prüfdauer: 8 h, Kategorie: 1	P

Anmerkung: *Es ist Staub in geringer Menge eingedrungen.
Es darf Staub eindringen in einer solchen Menge, dass das ordnungsgemäße Arbeiten des Betriebsmittels oder die Sicherheit nicht beeinträchtigt ist.*

Die Schutzartprüfung IP 5X wurde erfüllt.

2.2.2 Schutz gegen Wasser, bezeichnet durch die zweite Kennziffer nach EN 60529

Zweite Kennziffer	Prüfmittel	Wasservolumenstrom	Prüfdauer	Status
5	Strahldüse, Düse 6,3 mm Durchmesser, Abstand 2,5 bis 3 m	12,5 l/min \pm 5%	3 min	P

Die Schutzartprüfung IP X5 wurde erfüllt.



3 Messmittelliste

Messmittel	PM Nr.
IP-Raum Wasser	490021
Stoppuhr	481642
Staubkammer, Weiss ST 2000	490019

4 Bilder

Bild 1: Prüfaufbau vor der Prüfung



Bild 2: Prüflinge nach der Prüfung



Bild 3: Prüfling nach der Staubprüfung, exemplarisch



Bild 4: Detailbild Prüfling, exemplarisch



Bild 5: Prüfaufbau IP X5



Bild 6: Prüfling modifiziert vor den Prüfungen vom Auftraggeber





5 Bilderverzeichnis





Bild 1:	Prüfaufbau vor der Prüfung	12
Bild 2:	Prüflinge nach der Prüfung	12
Bild 3:	Prüfling nach der Staubprüfung, exemplarisch	13
Bild 4:	Detailbild Prüfling, exemplarisch	13
Bild 5:	Prüfaufbau IP X5	14
Bild 6:	Prüfling modifiziert vor den Prüfungen vom Auftraggeber	14

Annex No. 4

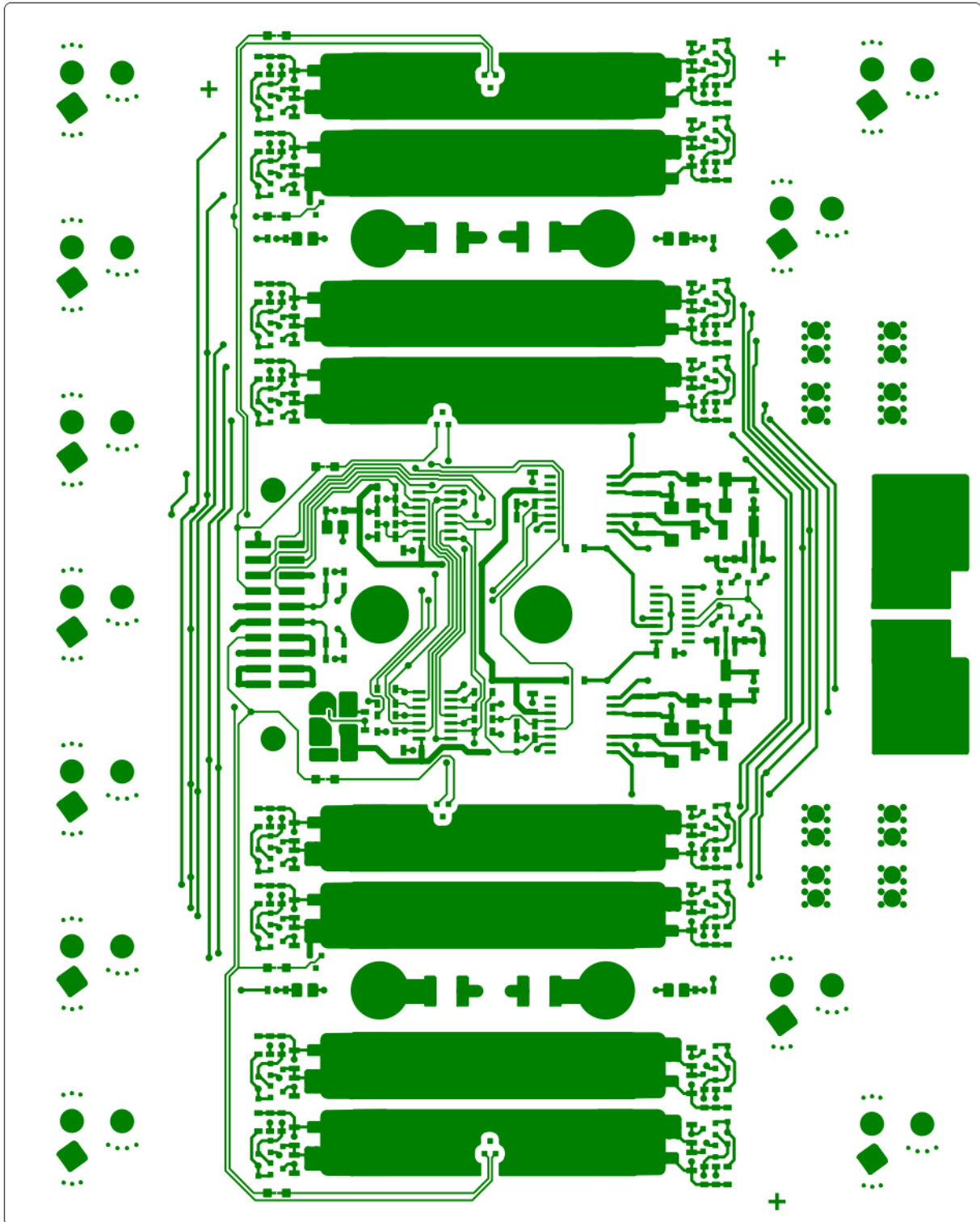
Schematics, Layouts, Transformer Analysis

SIWRS-11 board



1	2	3	4	5	6	7	8	9	10
OVERVIEW	CONNECTORS	BRIDGE	MOSFET-driver	interlock for gate signals					
sheet 1	sheet 2	sheet 3	sheet 4	sheet 5					
<p>      </p> <p> Layouttautelle BUREAU VERITAS 40-404511 Revision: 01 SMA Technologies AG 12/12/05 SIMRS-11.01D/SP/A4-412 Page 1 of 5 </p>									

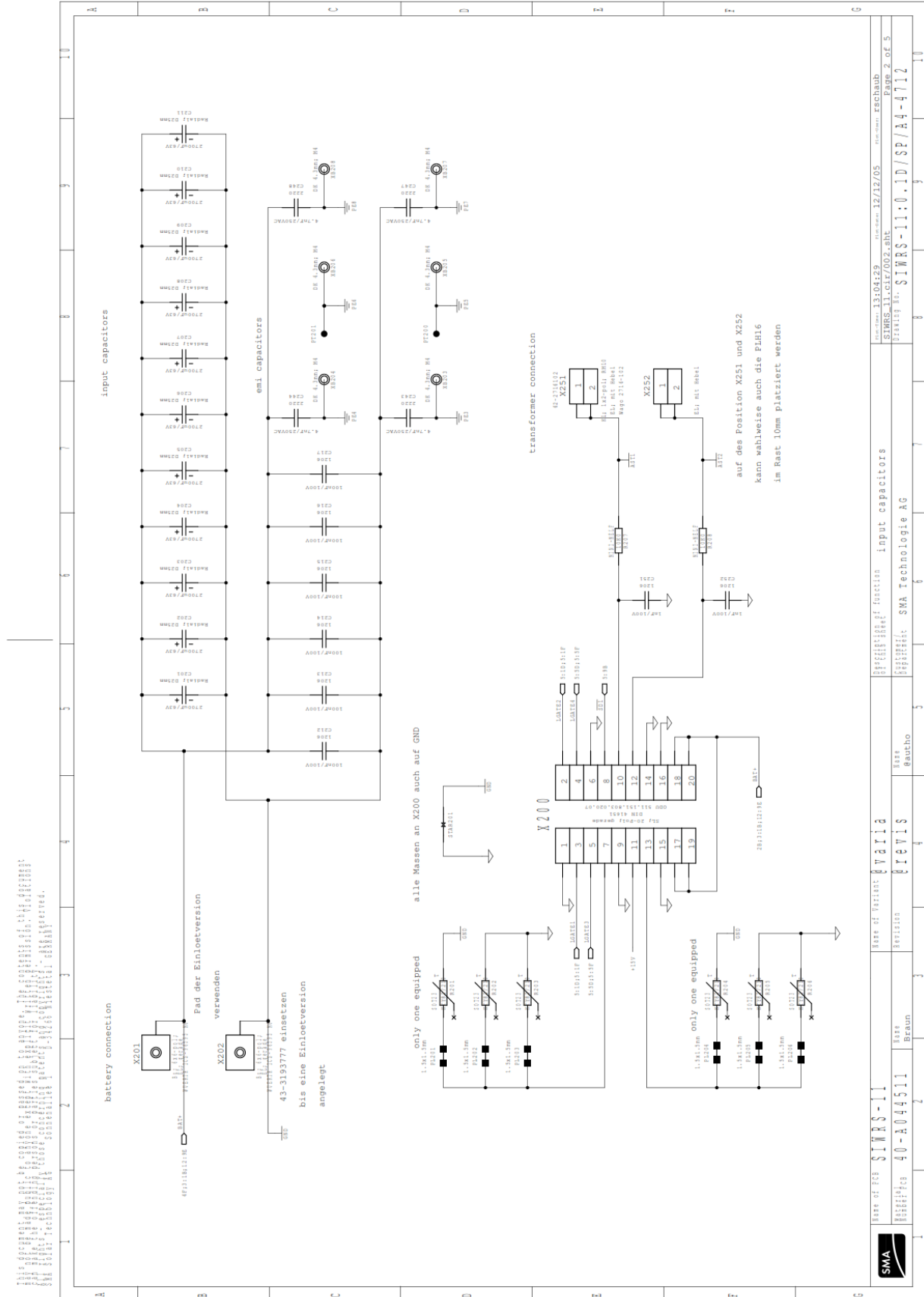

	Base of test: SIMRS-11 Material No: 40-A04511 Base: Braun	Revision: 1 Base of Report: VAVIA Name of Report: VAVIA	Department of function: input capacitors Customer: SMA Technologie AG Separator: SMA Technologie AG	Date: 12/12/05 Drawn: eschaub Checked: eschaub Page: 2 of 5
---	--	--	--	--

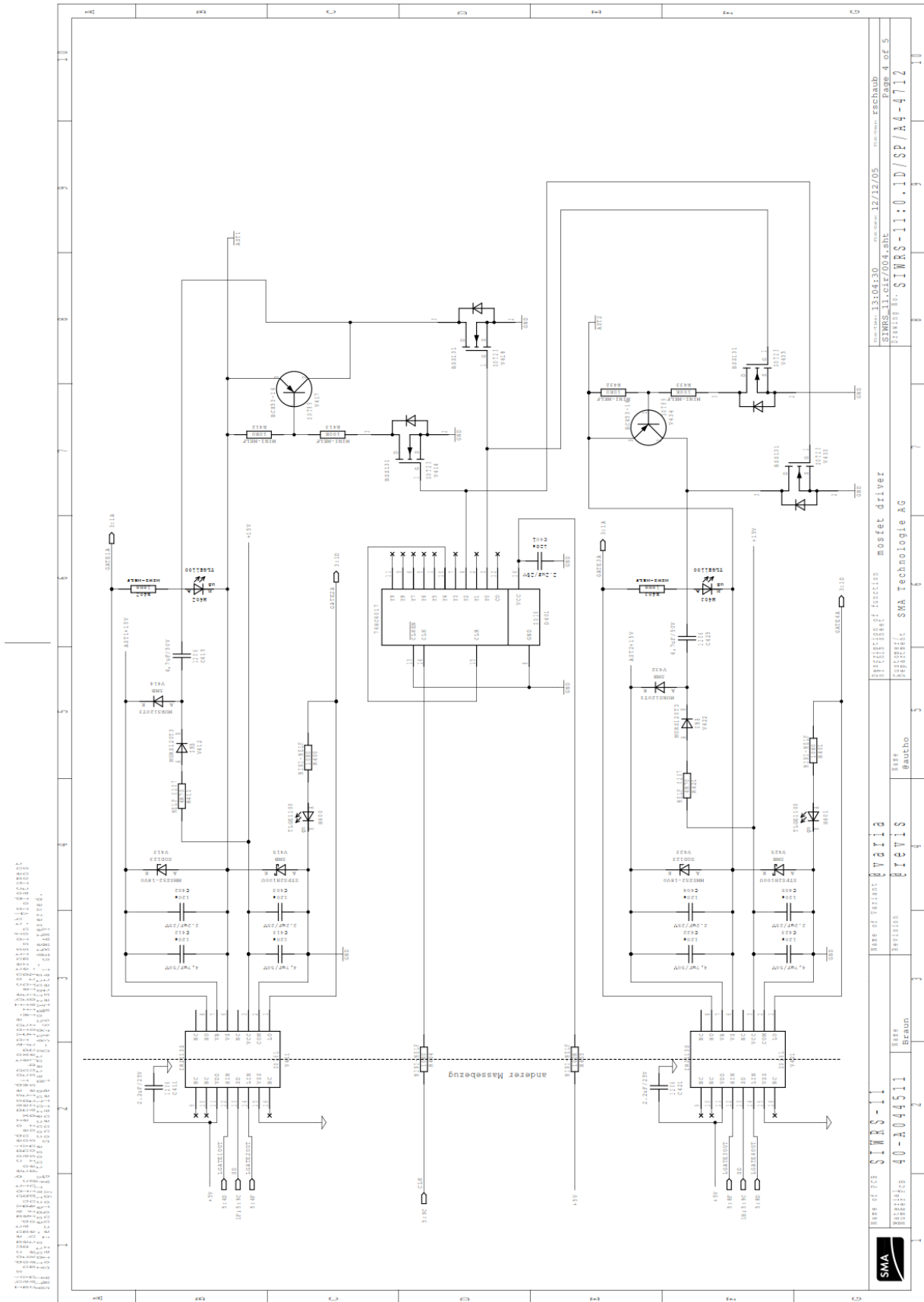

SIAST50-48

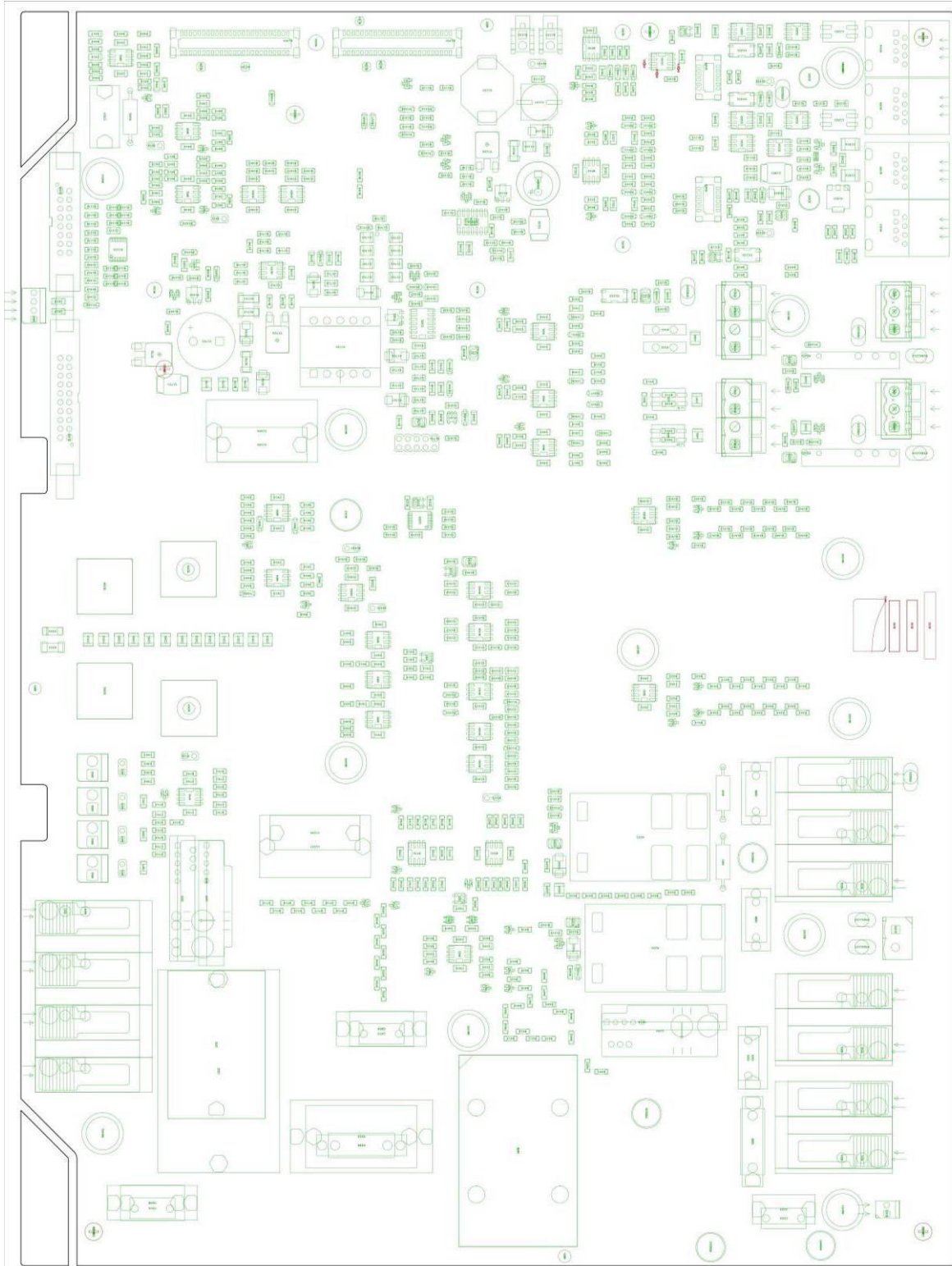

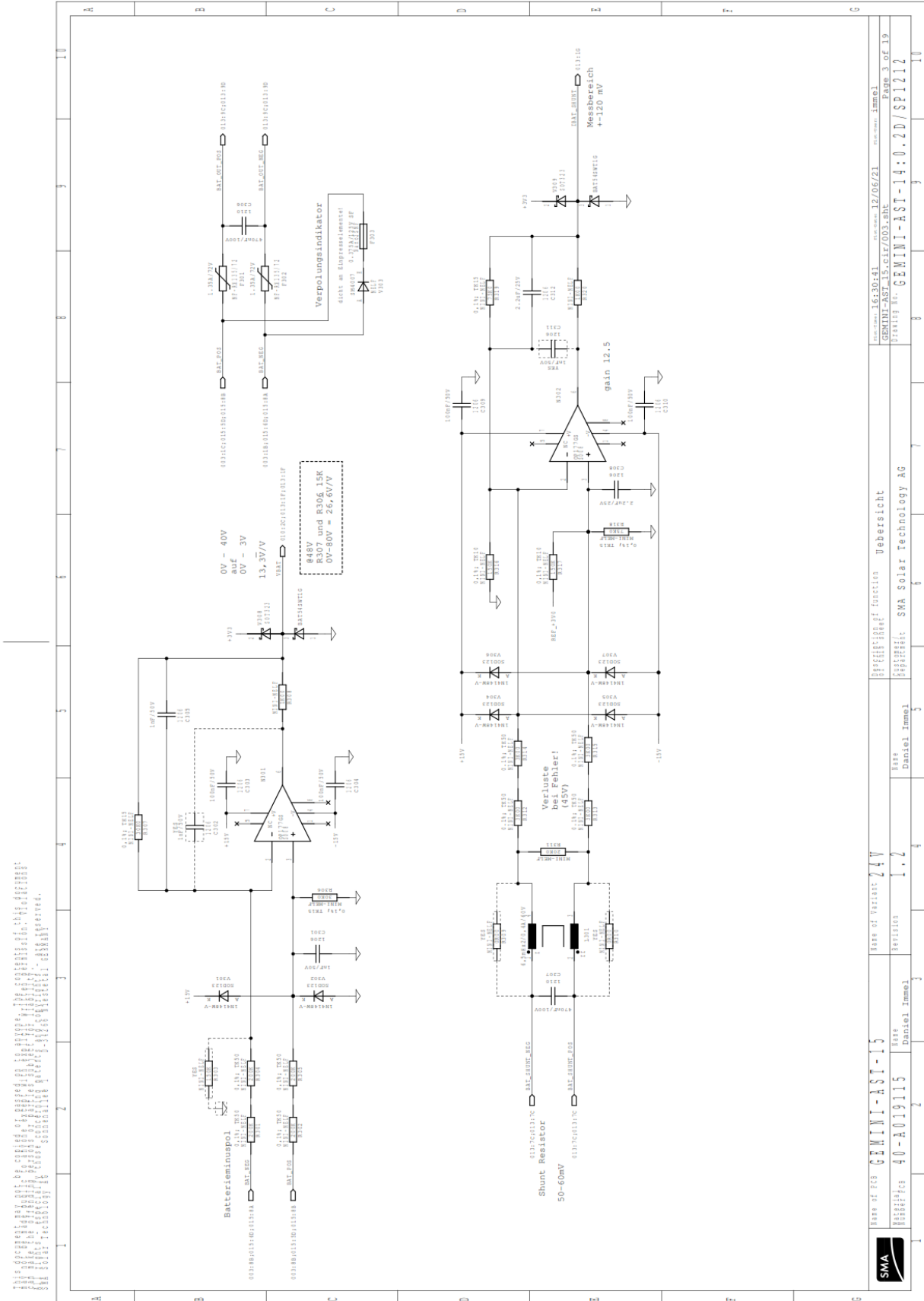

	Name of PCB: GEMINI-AST-15 Revision: 1.2 Name: Daniel Immel	Description of function: Uebersicht Customer: SMA Solar Technology AG Date: Daniel Immel	Date: 16.03.21 File: GEMINI-AST-15_cir/003.mht Page: 3 of 19 Drawing No.: GEMINI-AST-14:0.2D/SP12
--	---	--	--

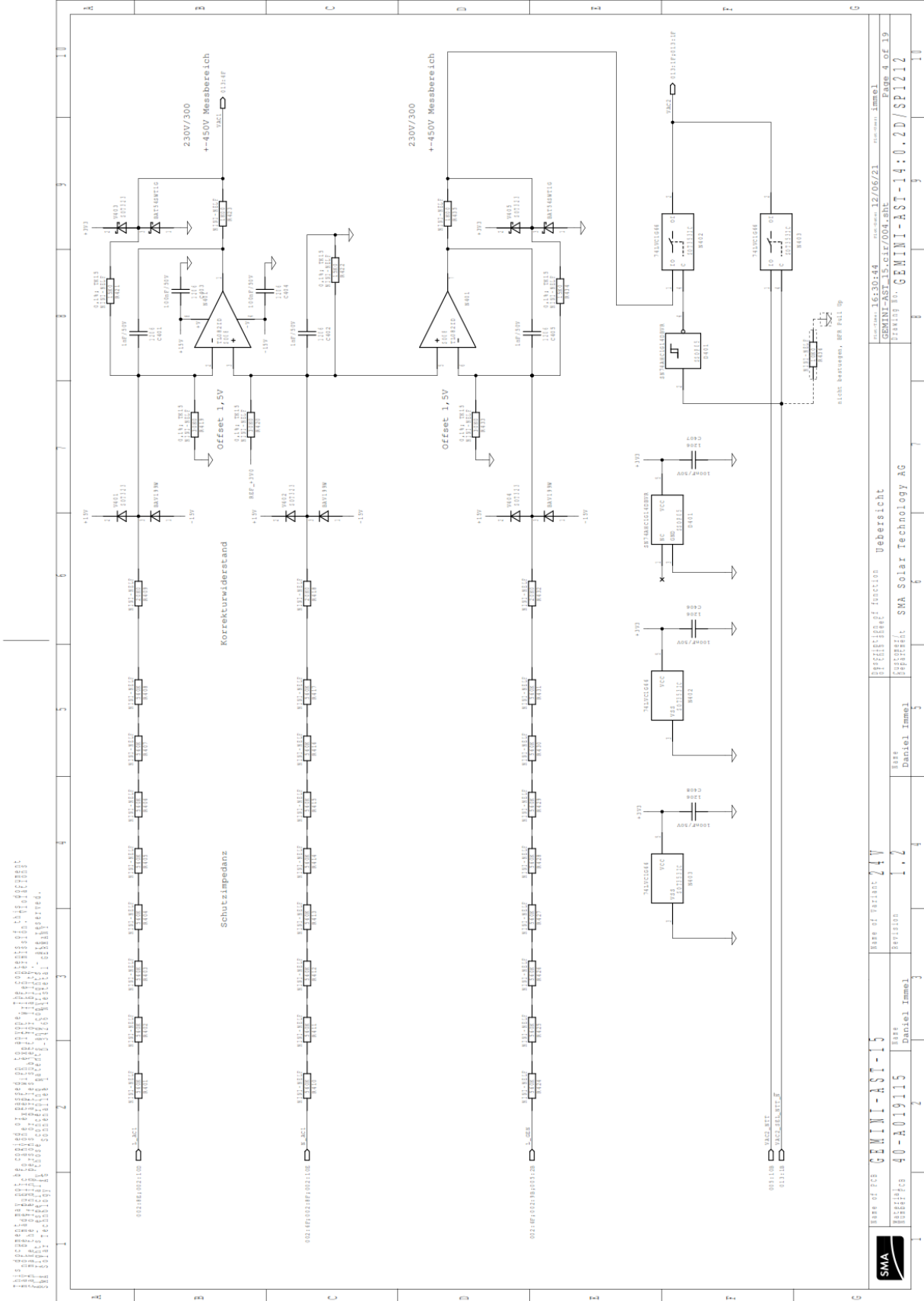

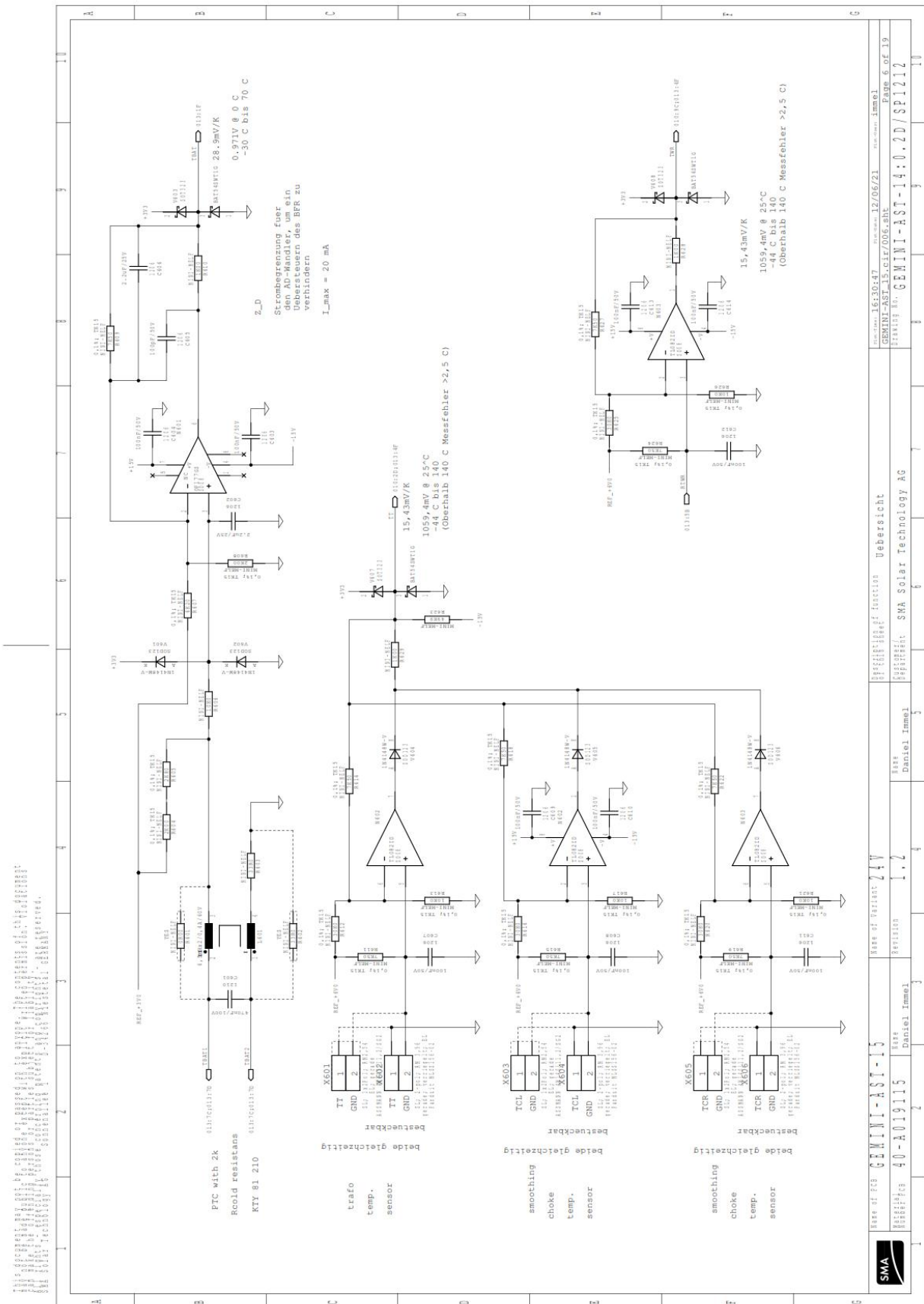

Issue of PCB	GEMINI-AST-15	Issue of Report	2.1.1
Author	Daniel Immel	Revision	1.1
Specification of function	Uebersicht	Issue of drawing	12/06/21
Customer	GEMINI-AST-15.cir/006.sht	Page	6 of 19
Manufacturer	SMA Solar Technology AG	Part No.	GEMINI-AST-15.0.2D/SP122

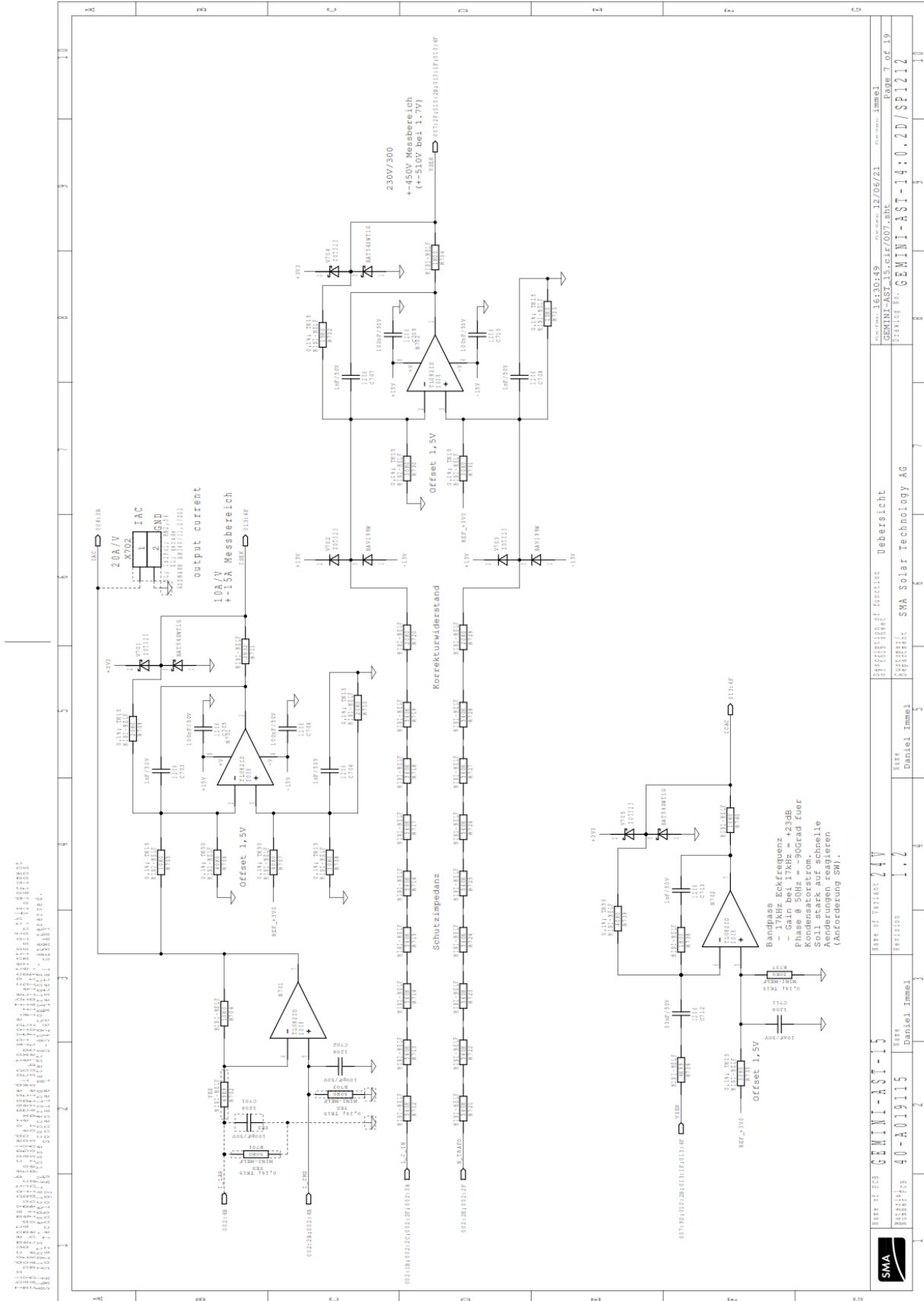

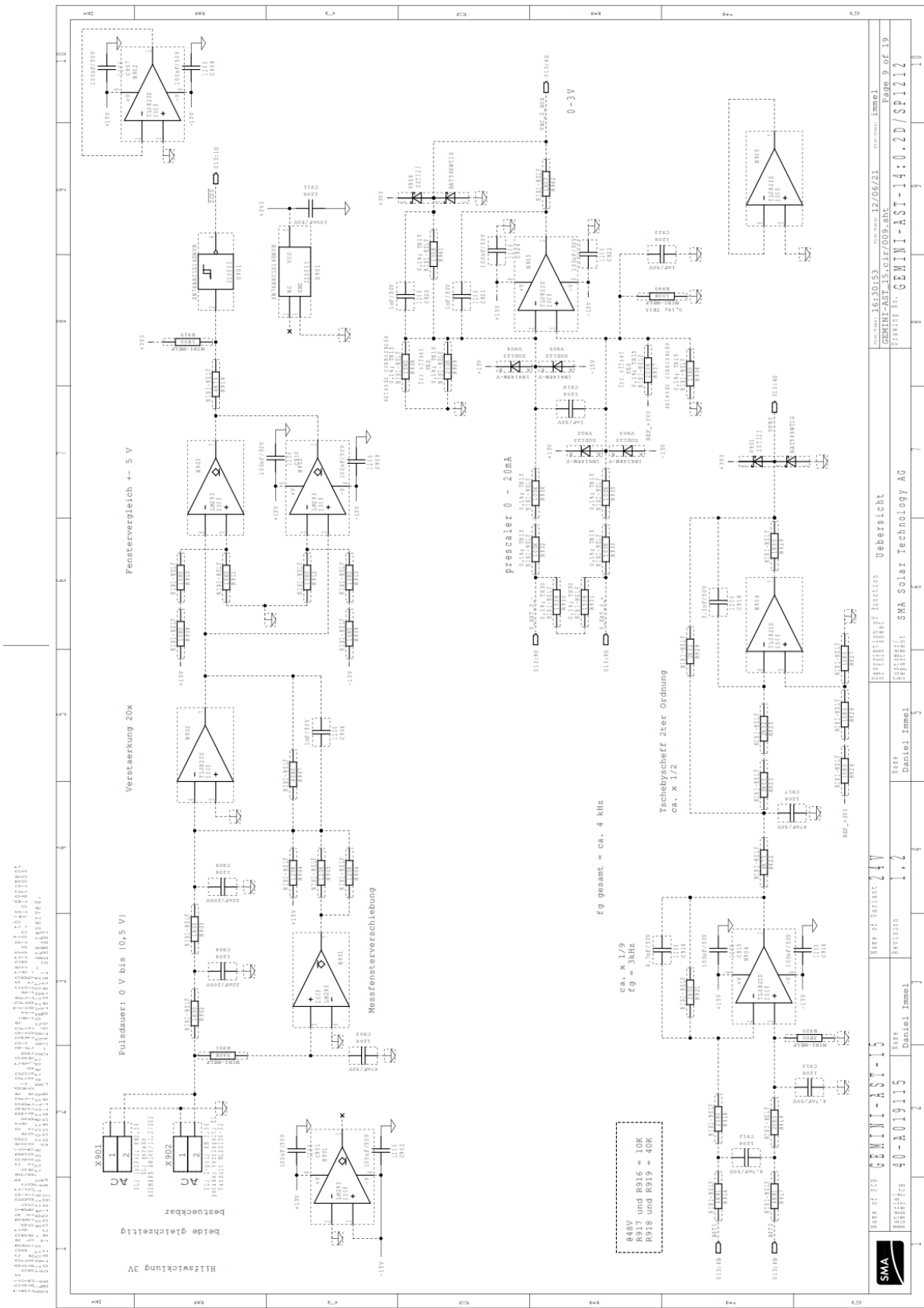

Date: 12/06/21		Author: Daniel Immel	
Project: GEMINI-AST-15		Revision: 1.2	
Customer: SMA Solar Technology AG		Drawing: GEMINI-AST-15:02D/SP122	
Title: Überbericht		Scale: 1:1	
Base: Daniel Immel		Base: Daniel Immel	
Date of Issue: 12/06/21		Date of Revision: 12/06/21	
Issue of Issue: 12/06/21		Issue of Revision: 12/06/21	
Issue of Issue: 12/06/21		Issue of Revision: 12/06/21	

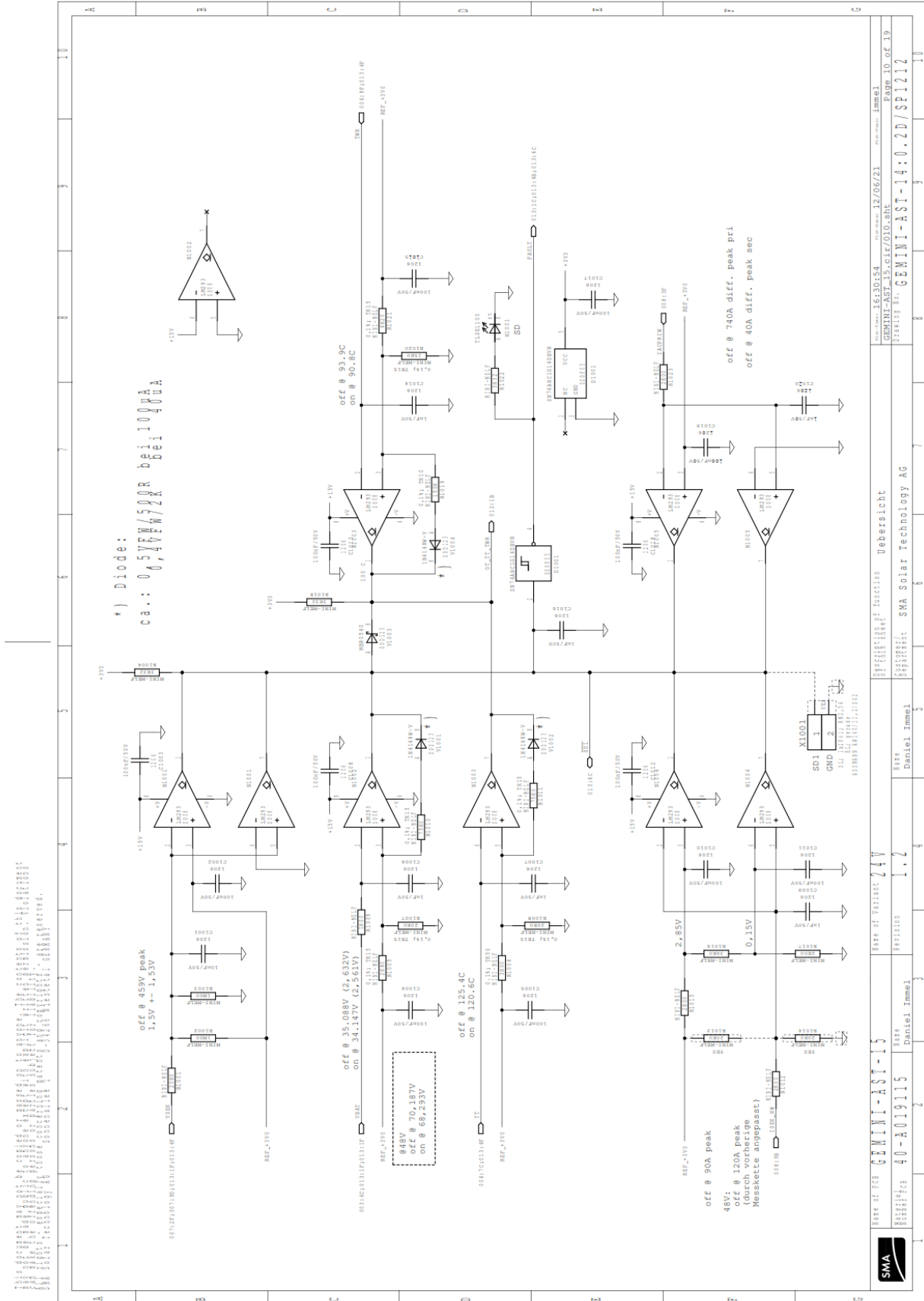

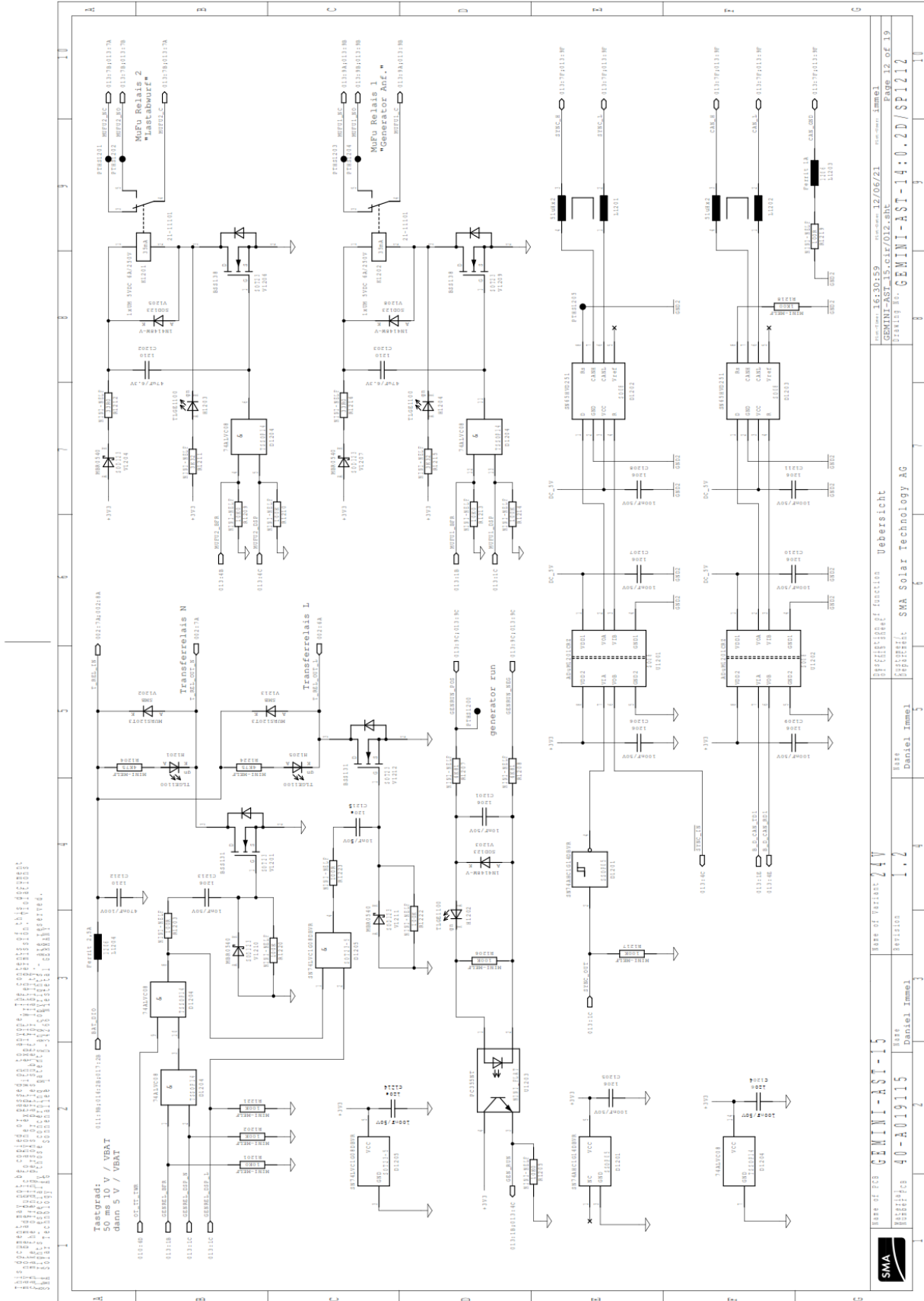

Testgrad:
50 ms 10 V / VBAT
dim 5 V / VBAT

Rev. of PCB	GEMINI-AST-15	Rev. of Part No.	24V	Rev. of Project	24V	Description of function	Übersicht	Rev. of Rev. No.	16.03.05.59	Rev. of Rev. No.	12/06/21	Rev. of Rev. No.	Immel
Part No.	40-A019115	Rev. No.	1.1	Rev. No.	1.1	Customer/Supplier	GEMINI-AST-15.cir/012.mht	Part No.	GEMINI-AST-15.cir/012.mht	Part No.	GEMINI-AST-15.cir/012.mht	Part No.	GEMINI-AST-15.cir/012.mht
Manufacturer	SMA Solar Technology AG	Manufacturer	SMA Solar Technology AG	Manufacturer	SMA Solar Technology AG	Manufacturer	SMA Solar Technology AG	Manufacturer	SMA Solar Technology AG	Manufacturer	SMA Solar Technology AG	Manufacturer	SMA Solar Technology AG
Base	Daniel Immel	Base	Daniel Immel	Base	Daniel Immel	Base	Daniel Immel	Base	Daniel Immel	Base	Daniel Immel	Base	Daniel Immel

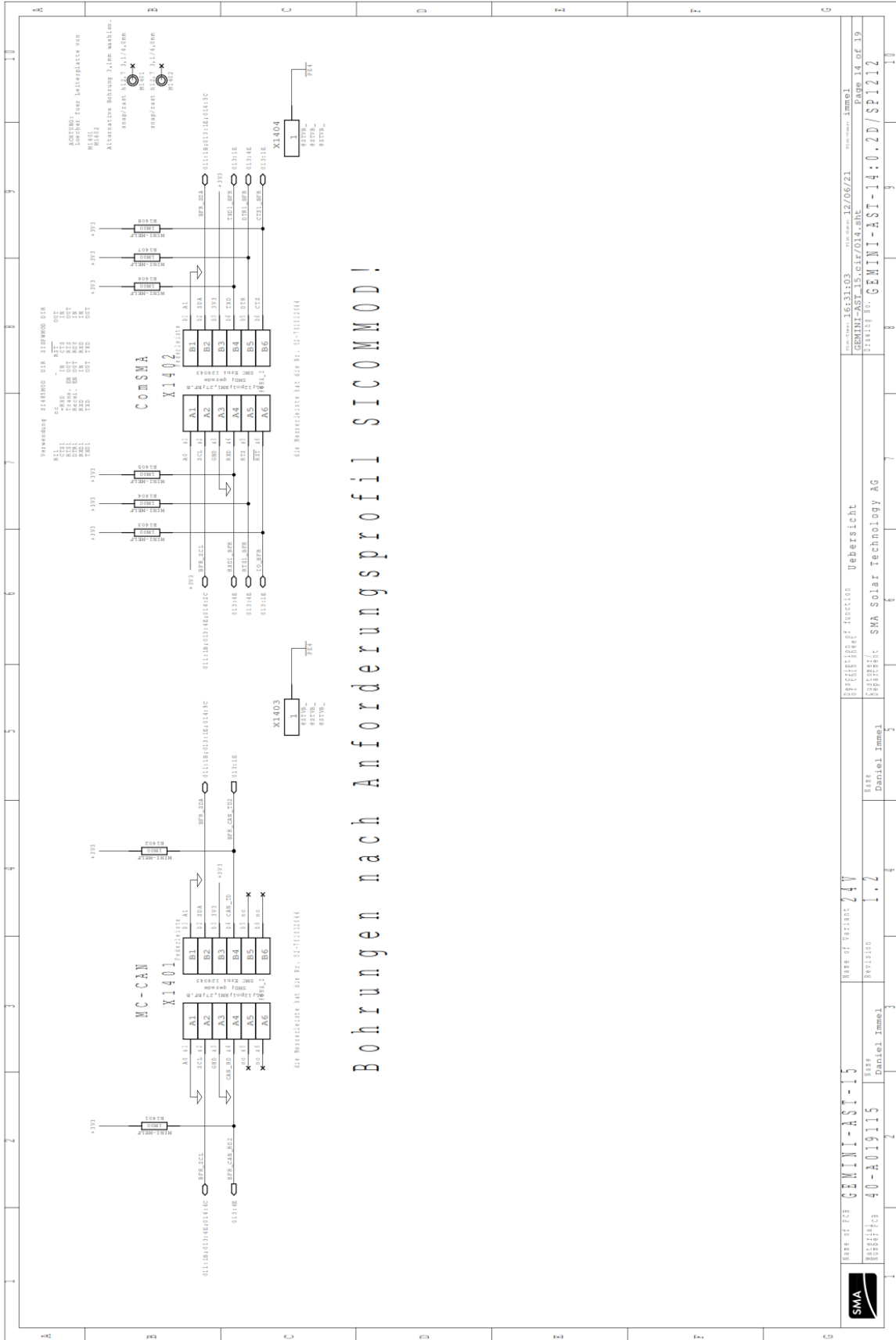

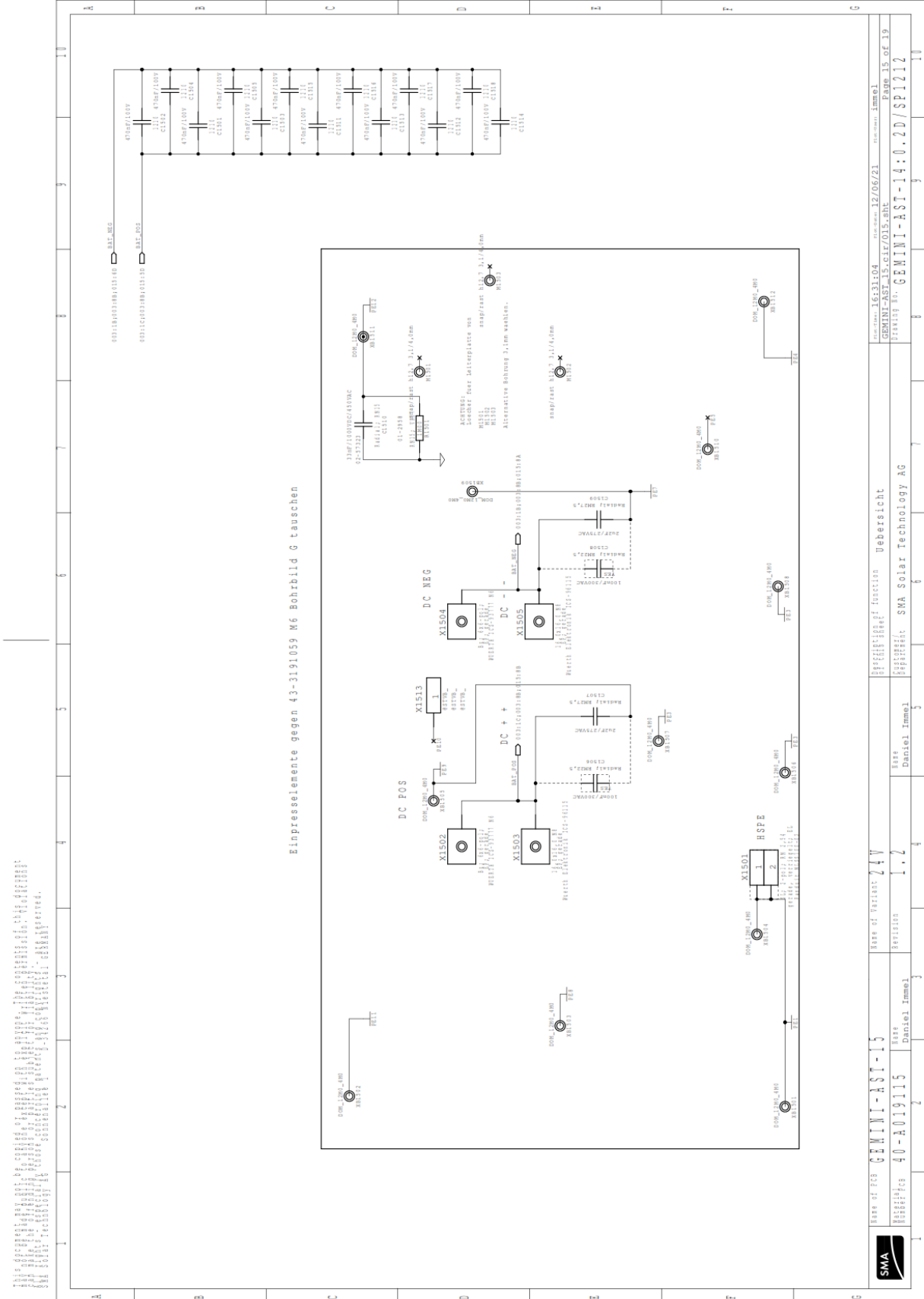

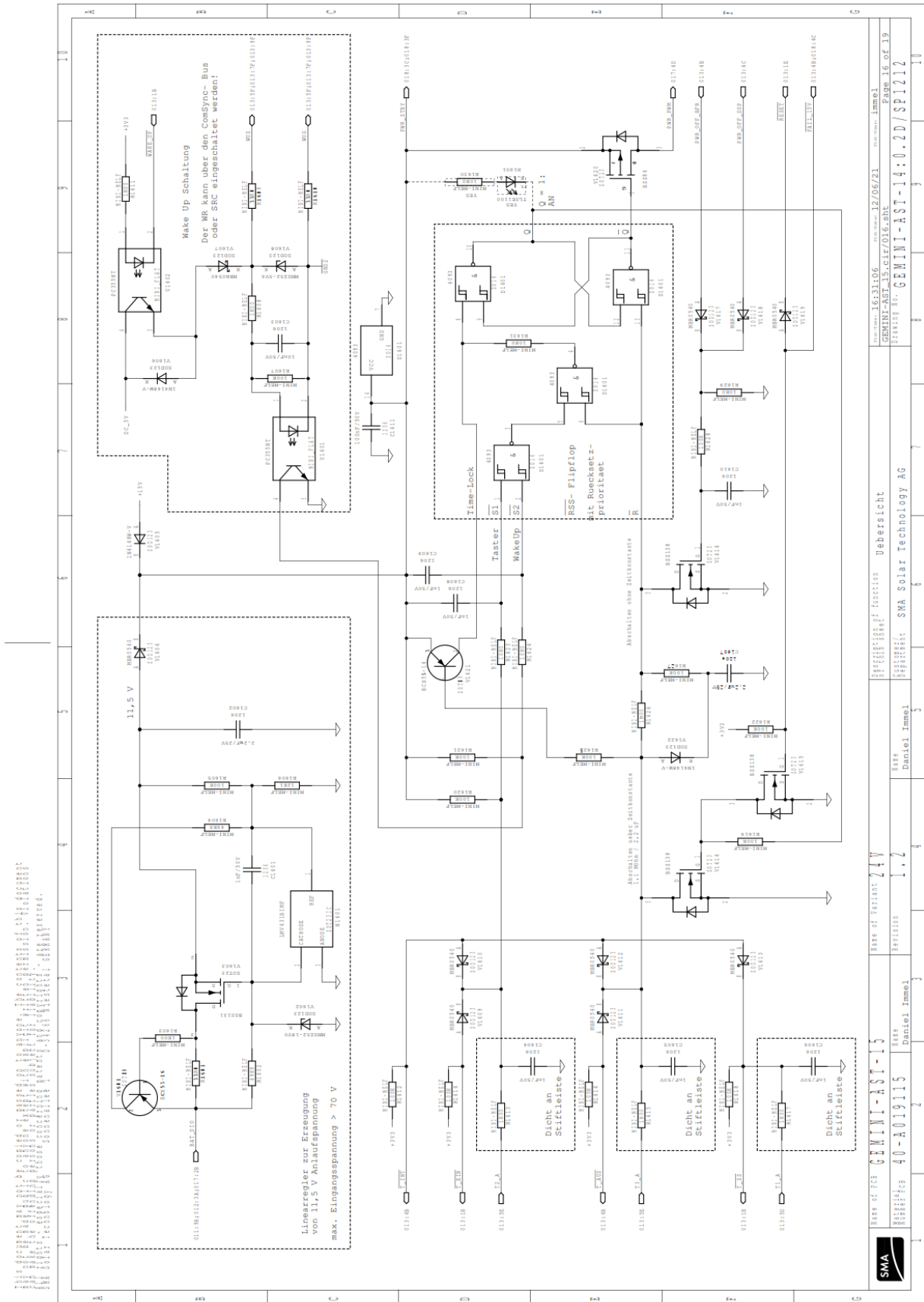

SMA		Bestell-Nr.: 40-A019115	Revisio:	1.1	Base:	Daniel Immel	Geprüft:	SMA Solar Technology AG	Version:	GEMINI-AST-15:0.2D/SP122
SMA		Bestell-Nr.: 40-A019115	Revisio:	1.1	Base:	Daniel Immel	Geprüft:	SMA Solar Technology AG	Version:	GEMINI-AST-15:0.2D/SP122
SMA		Bestell-Nr.: 40-A019115	Revisio:	1.1	Base:	Daniel Immel	Geprüft:	SMA Solar Technology AG	Version:	GEMINI-AST-15:0.2D/SP122

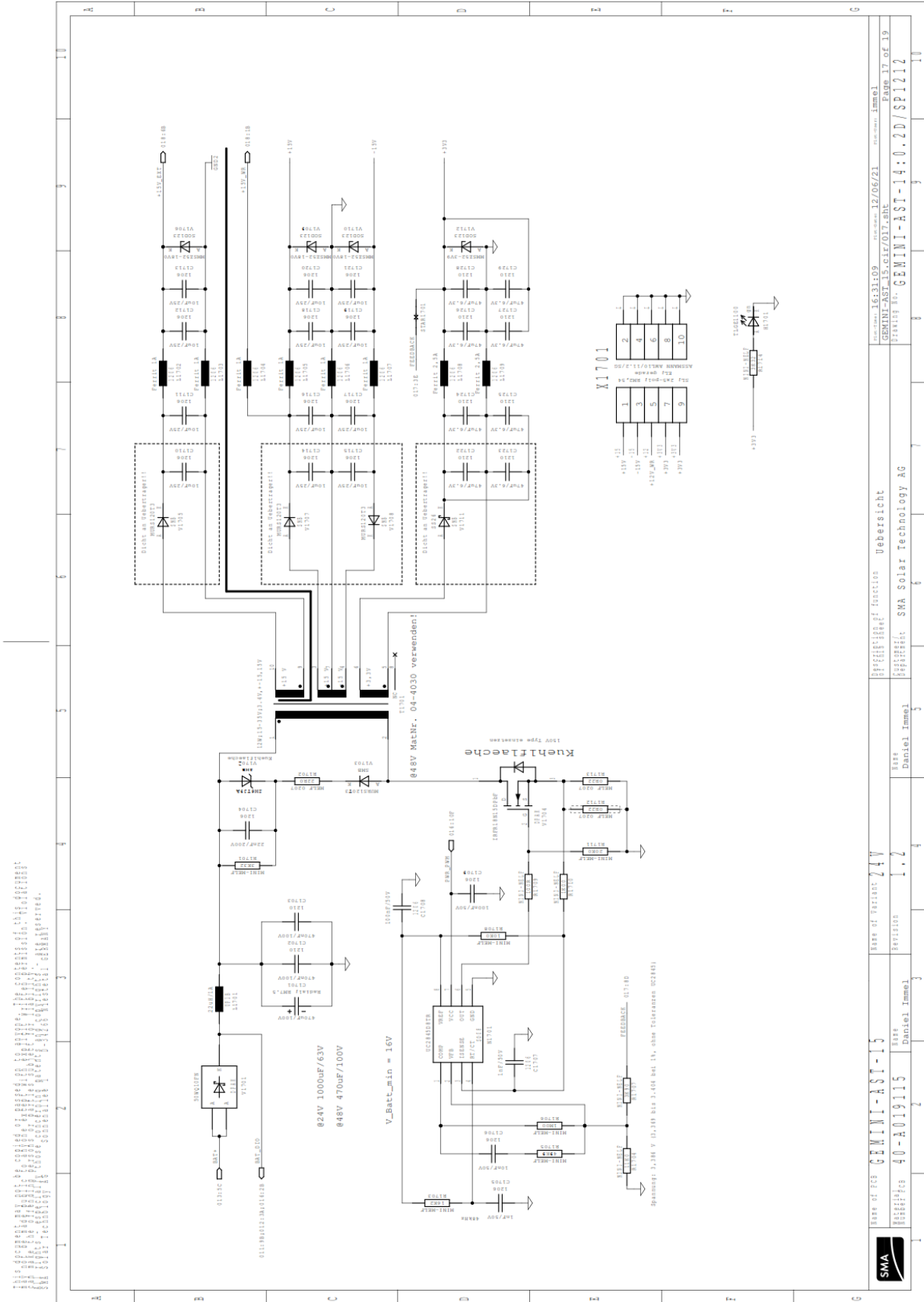

	Name of PCB: GEMINI-AST-15 Revision: 40-A019115 Base: Daniel Immel	Name of function: Uebersicht Customer: SMA Solar Technology AG Designer: Daniel Immel	Date: 16.03.19 Date: 12/06/21 Page: 17 of 19
	Name of project: 24V Revision: 1.2 Base: Daniel Immel	Name of project: GEMINI-AST-14:0.2D/SP12 Date: 12/06/21 Page: 17 of 19	Name of project: GEMINI-AST-15.cir/017.sht Date: 12/06/21 Page: 17 of 19

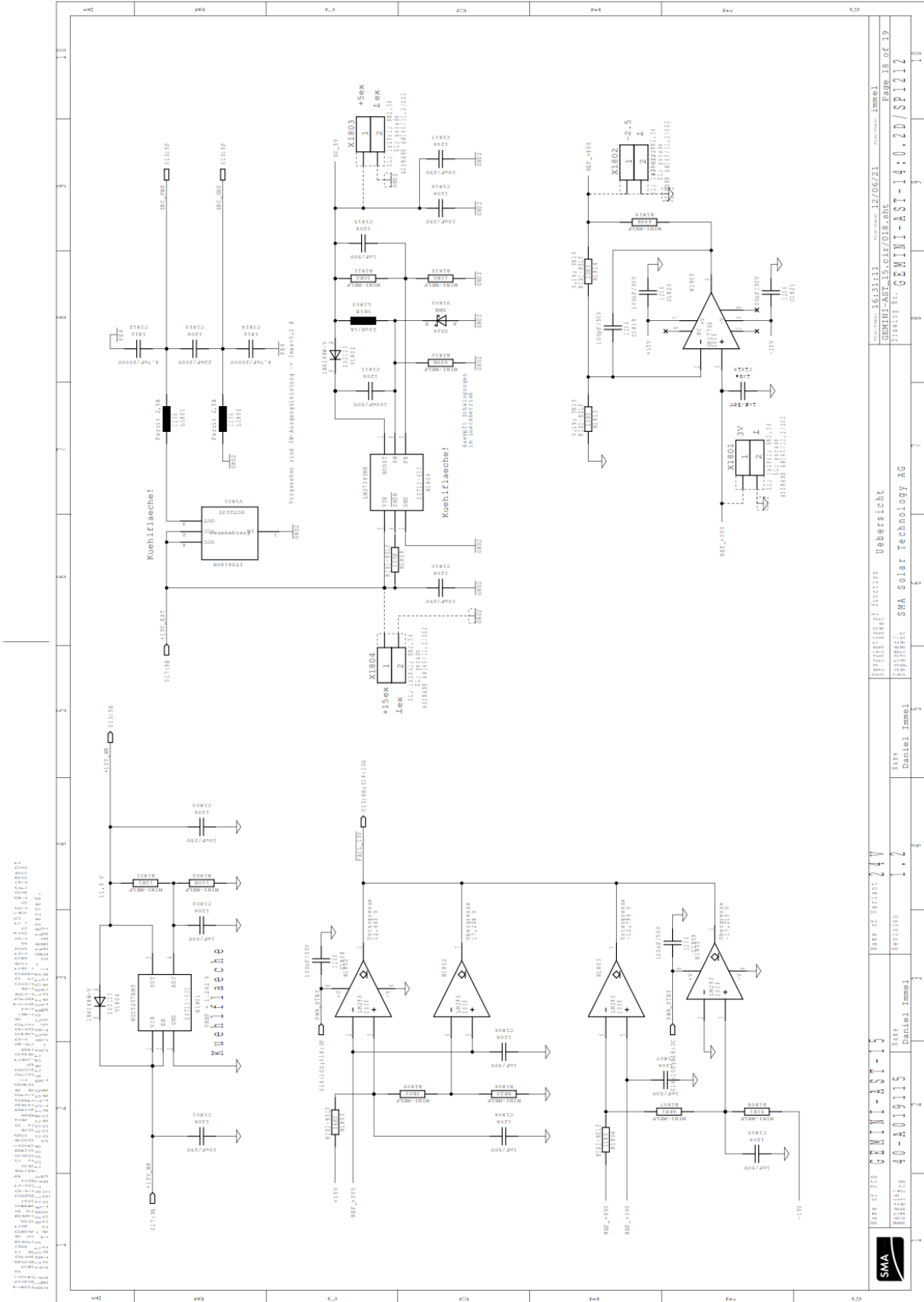

	Name of PCB: GEMINI-AST-15 Revision: 40-A19115	Name of function: Übersicht Drawing No.: GEMINI-AST-15.02D/SP112	Date: 12/06/21 Drawn by: Daniel Immel
Name: Daniel Immel	Revision: 1.2	Page: 18 of 19	Date: 12/06/21

PCB SIBFS33_14

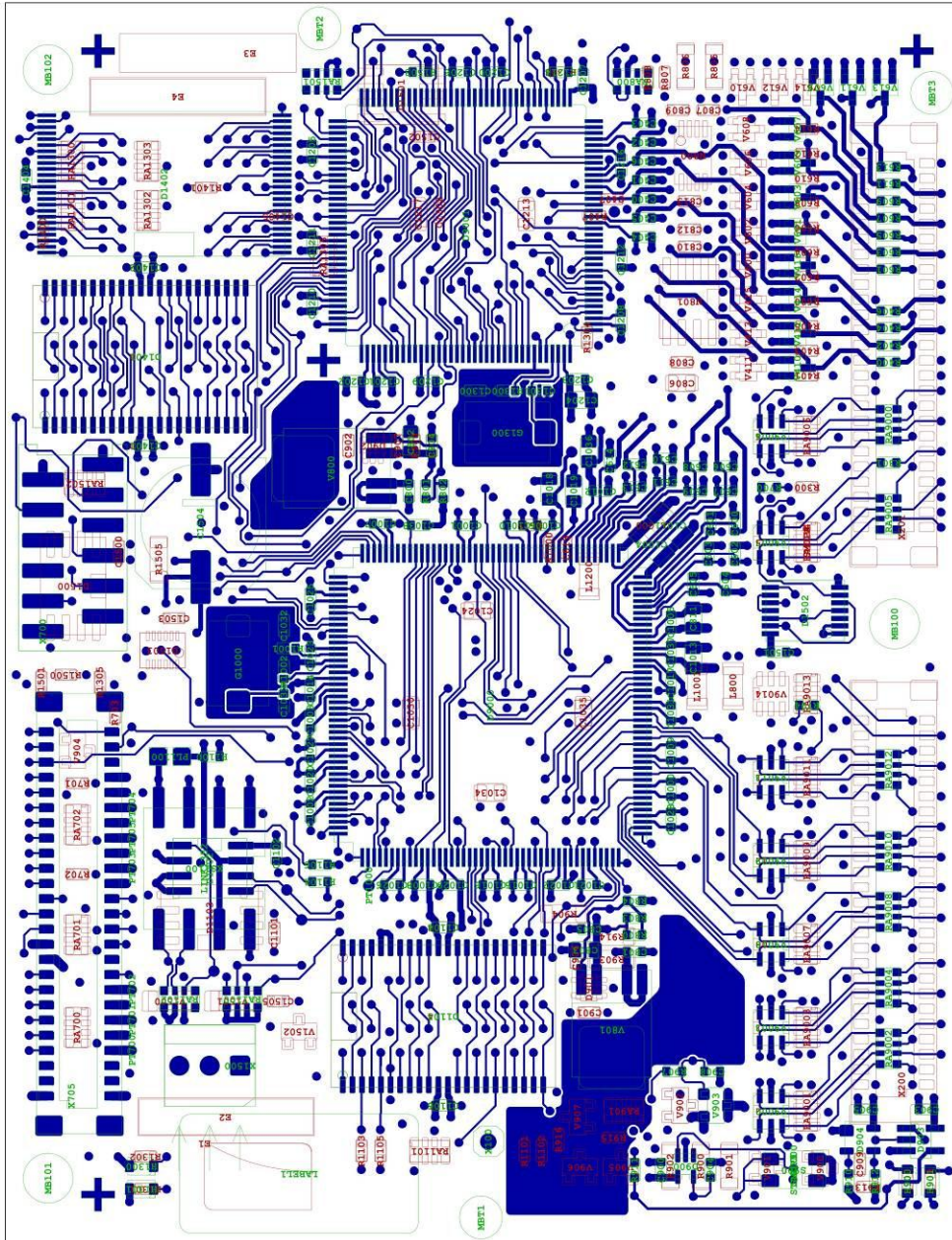

This document may not be copied or passed on to anyone. The contents of this document may not be made public to anyone, except with explicit written permission. Violations will result in legal action. All rights - especially those concerning patents and copyrights - are reserved. SMA Solar Technology AG Sonnenallee 1 42799 Solingen GERMANY

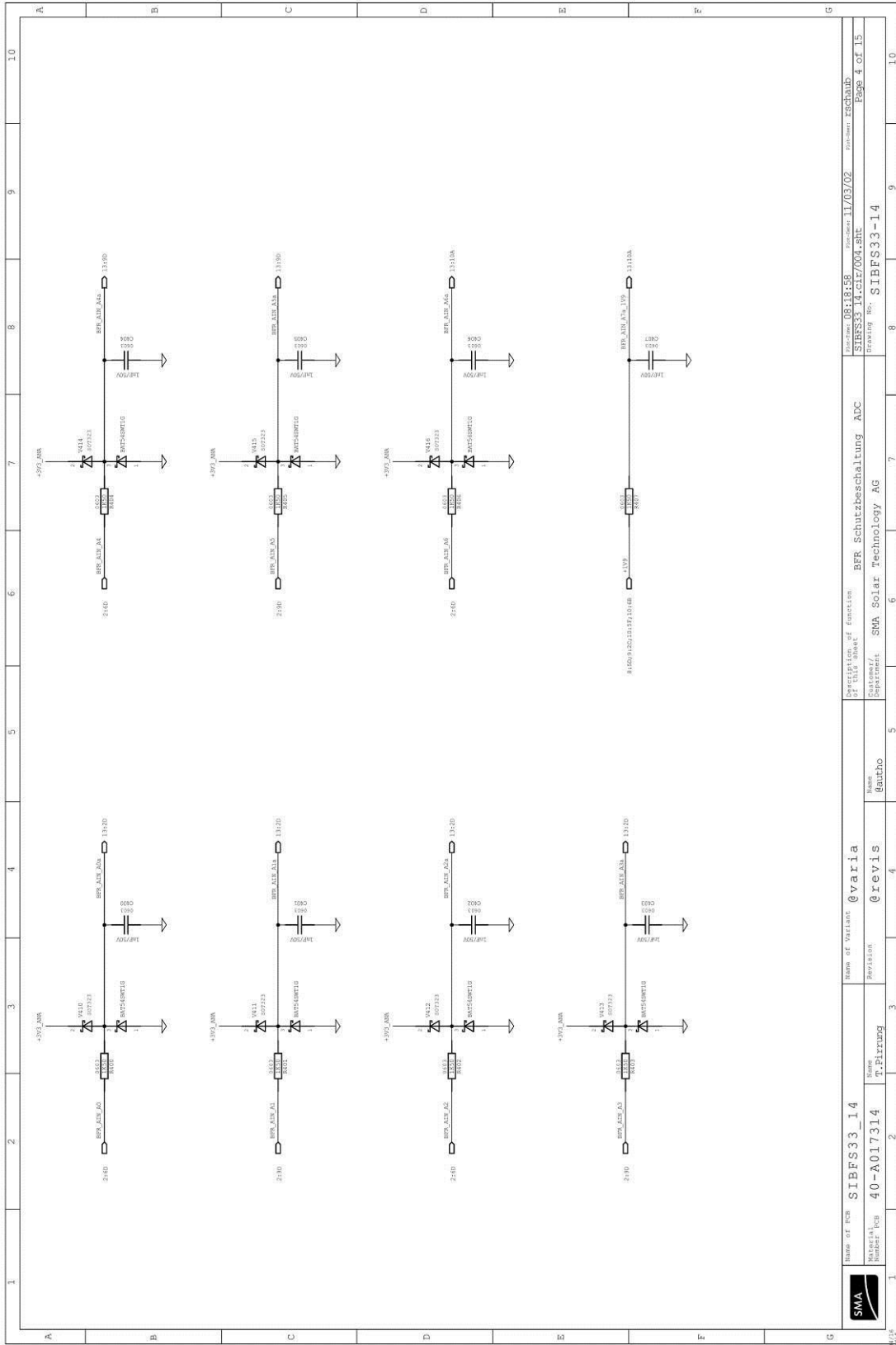

1	2	3	4	5	6	7	8	9	10	
	Item of PCB SIBFS33_14	Name T.Pfarrung	Revision @revis	Name of Variant @varia	Department @autro	Function of Function BFR Schutzbeschaltung ADC	Manufacturer SMA Solar Technology AG	Project No. SIBFS33-14	Revision No. 11/03/02	Page 4 of 15

This document may not be copied or passed on to anyone. The contents of this document may not be made public to anyone except with explicit written permission. Violations of this document may result in legal action. All rights reserved. SMA Solar Technology AG - Sonnenteile 1 - 37106 Hildesheim, Germany

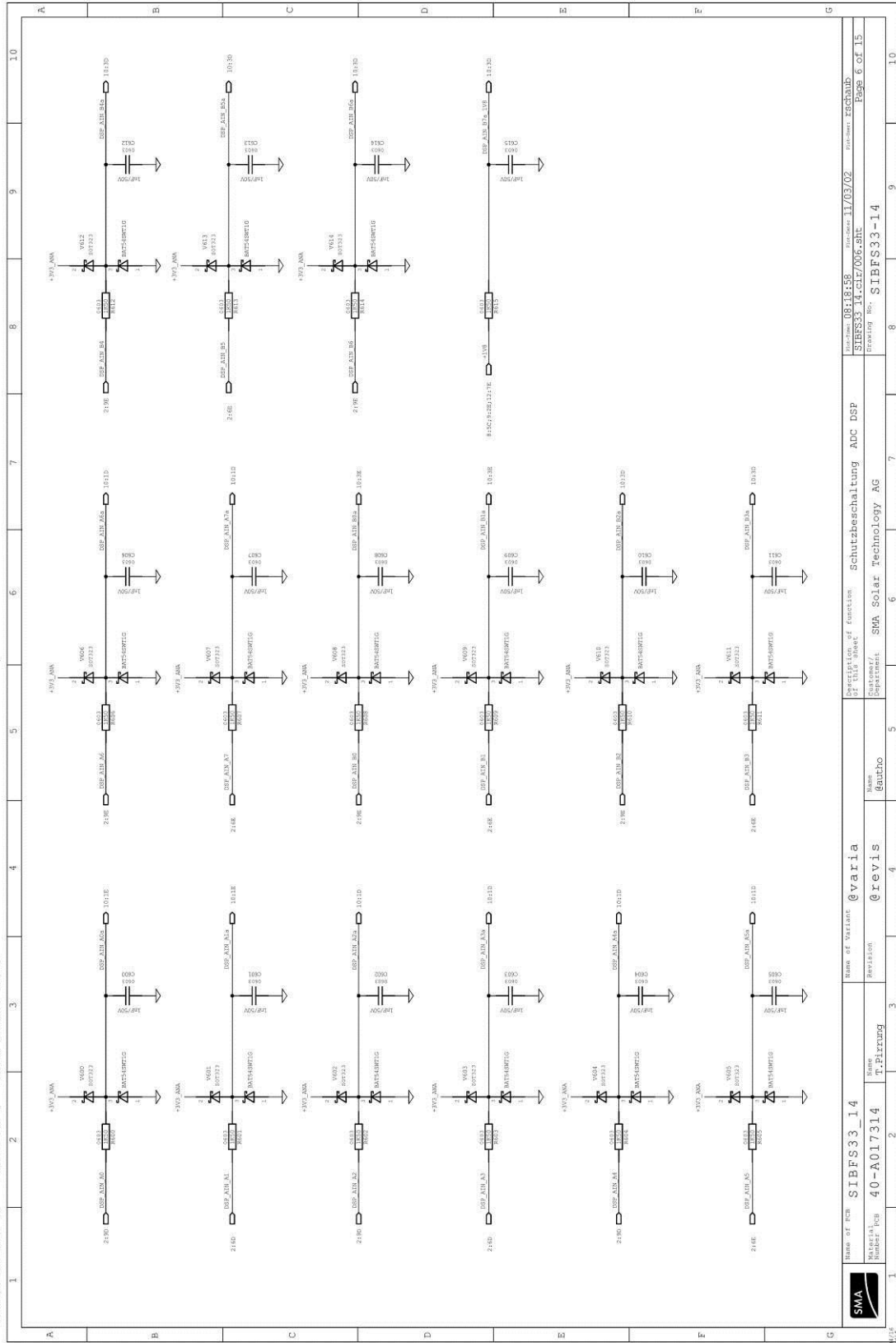

		Item of PCB: SIBFS33_14 Material: 40-A017314 Name: T.Pfurring	Name of Variant: @varia Revision:	Name: @autro Department:	Project: Schutzbeschaltung ADC DSP Date: 11/03/02	Drawing No.: SIBFS33-14 Page: 6 of 15
---	--	---	--------------------------------------	-----------------------------	--	--

This document may not be copied or passed on to anyone. The contents of this document may not be made public to anyone, except with explicit written permission. Violations of this document may result in legal action. All rights - especially those concerning patents and copyrights - are reserved. SMA Solar Technology AG Sonnenallee 1 32309 Hildesheim, Germany

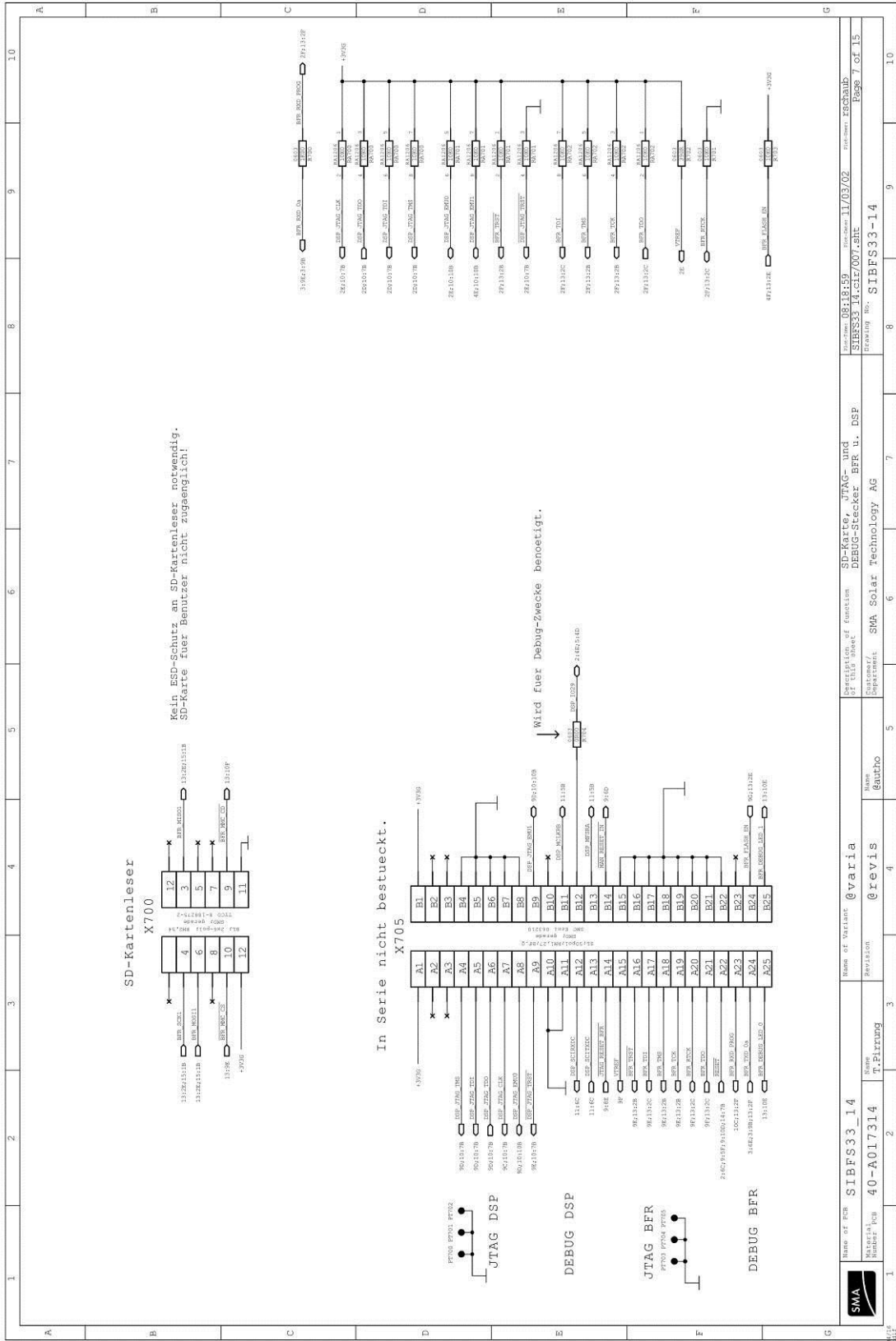

1	2	3	4	5	6	7	8	9	10
		Name of PCB: SIBFS33_14 Material: 40-A017314 Name: T.Pflurring Revision:	Name of Variant: @varia Name: @revis Revision:	Name of Function: SD-Karte, JTAG- und DEBUG-Steckere, BFR u. DSP Name: SMA Solar Technology AG Department:	Date of Issue: 08.18.16 Date of Revision: 11/03/02 Version: SIBFS33-14-017314-001 Revision: SIBFS33-14	Page 7 of 15			

This document may not be copied or passed on to anyone. The contents of this document may not be made public in any way, except with explicit written permission. Violations of this document may result in legal action. All rights reserved. SMA Solar Technology AG

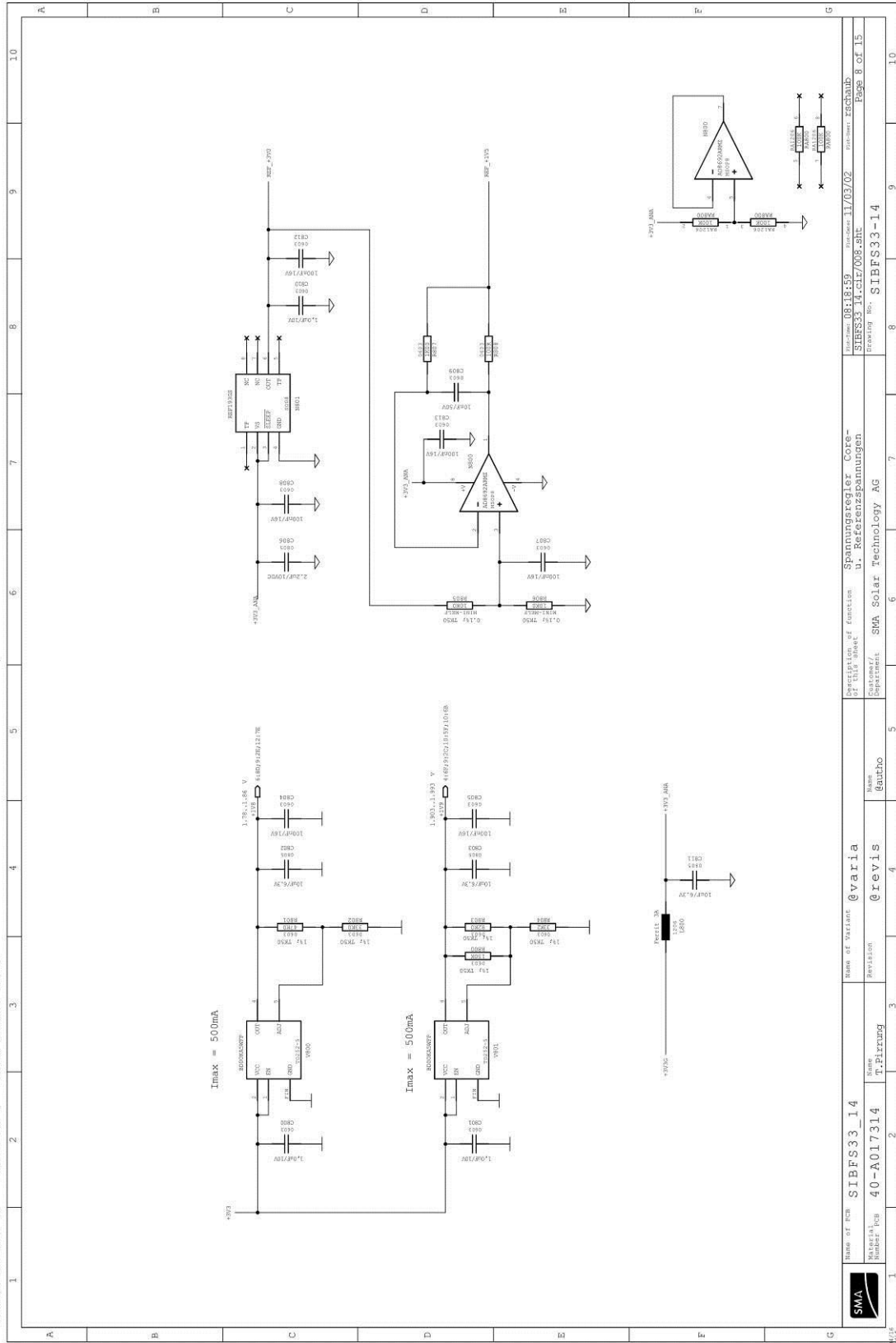

	Item of PCB Material: Number PCB	SIBFS33_14 40-A017314	Name T.Pfarrung	Revision @revis	Name of Variant @varia	Name @autro	Department SMA Solar Technology AG	Project Name SIBFS33-14	Date of Creation 11/03/02	Design SIBFS33-14	Page 8 of 15
---	--	--------------------------	--------------------	--------------------	---------------------------	----------------	---------------------------------------	----------------------------	------------------------------	----------------------	--------------

This document may not be copied or passed on to anyone. The contents of this document may not be made public to anyone except with explicit written permission. Violations of this policy - especially those concerning patents and copyrights - are reserved. SMA Solar Technology AG, Sonnenschein 1, D-71634 Metzingen, Germany

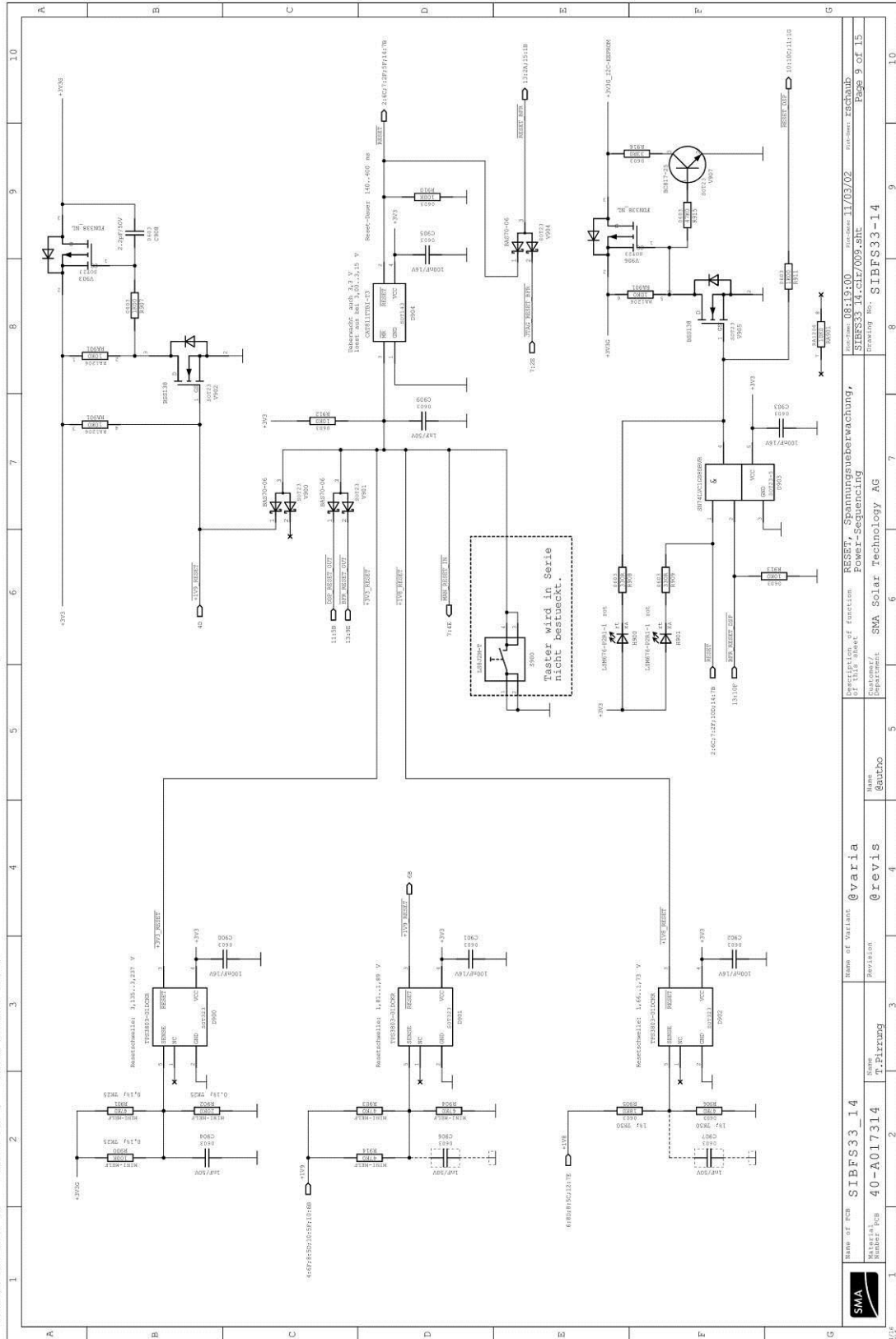

Item of PCB	SIBFS33_14	Name of Variant	@varia
Material Number PCB	40-A017314	Name	T.Pfarrung
		Revision	@revis
		Department	SMA Solar Technology AG
		Drawn/Checked	SIBFS33-14
		Drawn/Checked	SIBFS33-14
		Drawn/Checked	SIBFS33-14
		Drawn/Checked	SIBFS33-14
		Drawn/Checked	SIBFS33-14
		Drawn/Checked	SIBFS33-14
		Drawn/Checked	SIBFS33-14

This document may not be copied or passed on to anyone. The contents of this document may not be made public to anyone except with explicit written permission. Violations will be prosecuted. All rights reserved. SMA Solar Technology AG, Sonnenufer 1, D-73169 Metzingen, Germany

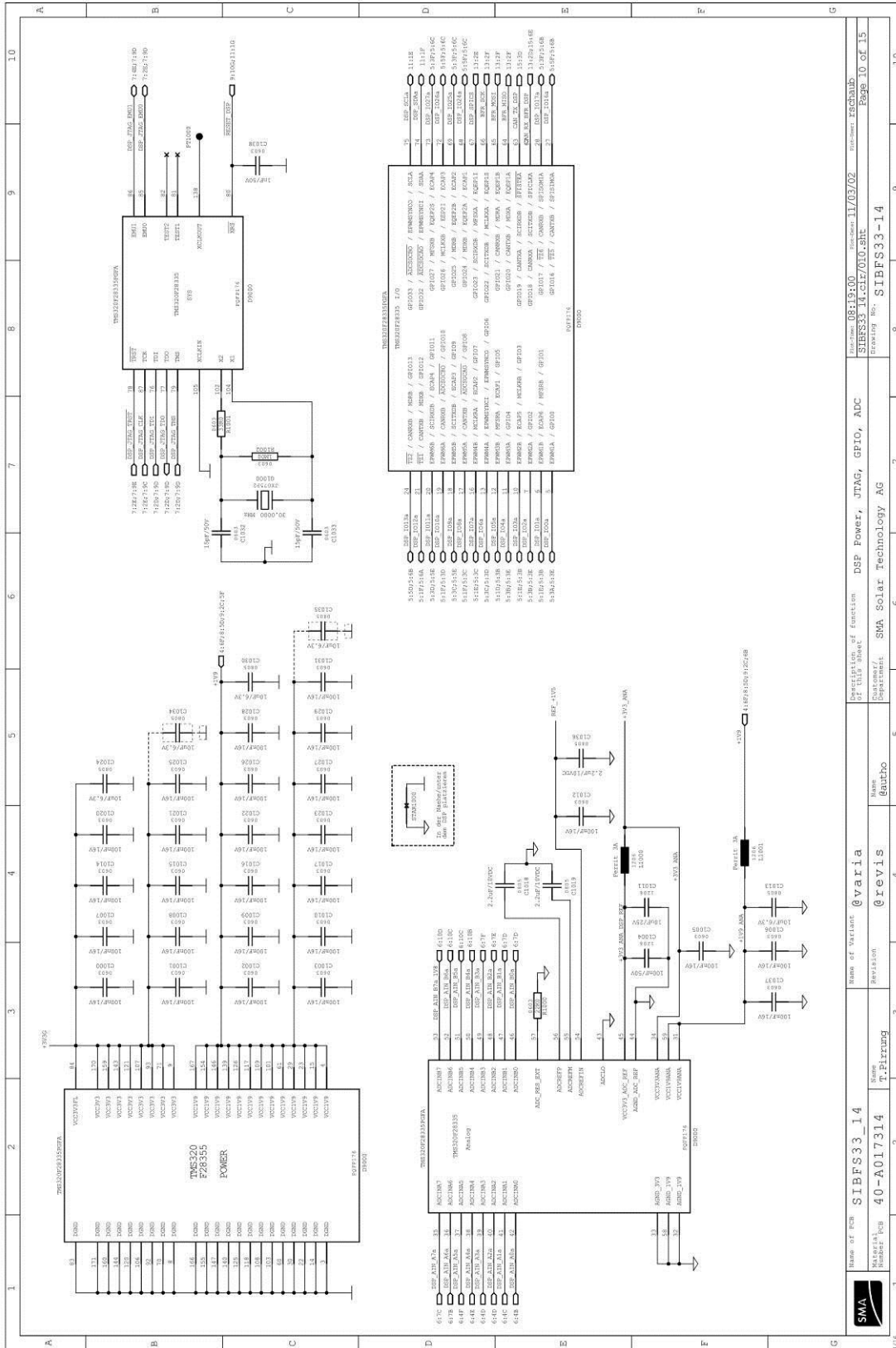

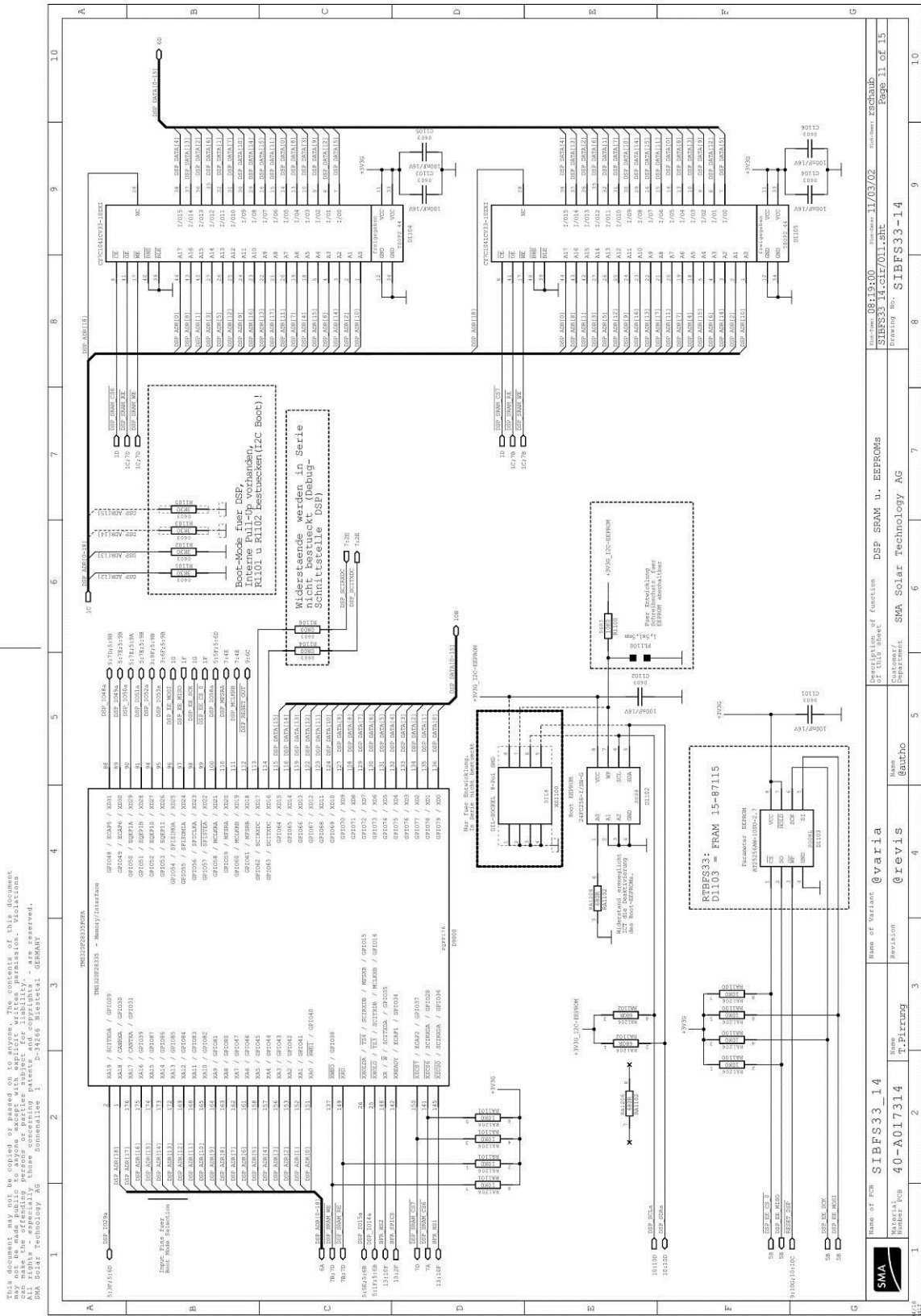

This document may not be copied or passed on to anyone. The contents of this document may not be made public to anyone except with explicit written permission. Violations of copyright law are strictly prohibited. All rights reserved. SMA Solar Technology AG, Sonnenallee 1, D-71636 Metzingen, Germany

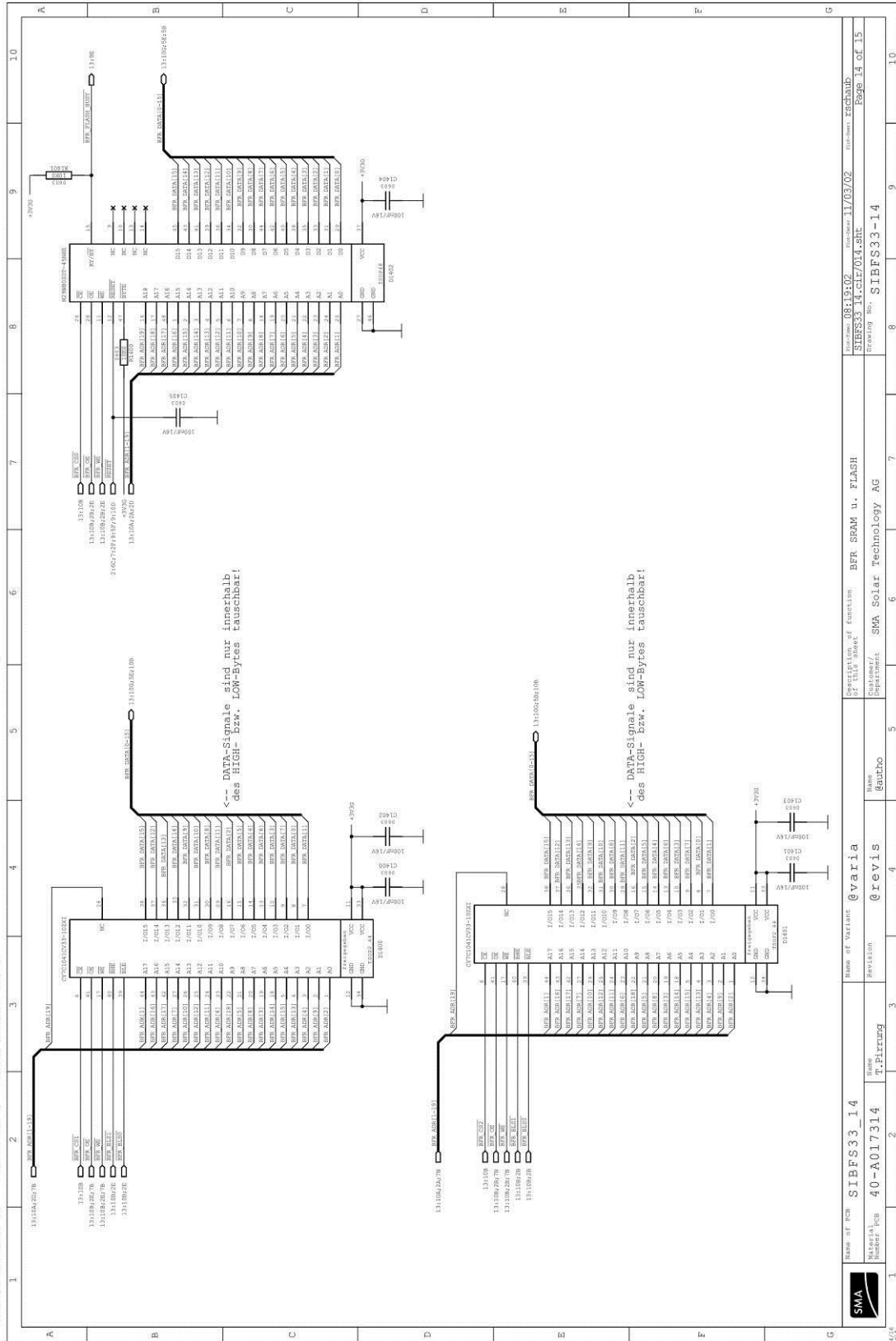

1	2	3	4	5	6	7	8	9	10
Item of PCB Material Number PCB	SIBFS33_14 40-A017314	Name T.Pfarrung	Revision	3	Name @varia @revis	Department SMA Solar Technology AG	Name (Gautro)	Revision	9
Item of Variant	SIBFS33_14	Name of Variant	SRAM u. FLASH	Revision	11/03/02	Name of Connection	SIBFS33_Tp217/014.che	Name of Variant	11/03/02
Item of Variant	SIBFS33_14	Name of Variant	SRAM u. FLASH	Revision	11/03/02	Name of Connection	SIBFS33_Tp217/014.che	Name of Variant	11/03/02
Item of Variant	SIBFS33_14	Name of Variant	SRAM u. FLASH	Revision	11/03/02	Name of Connection	SIBFS33_Tp217/014.che	Name of Variant	11/03/02

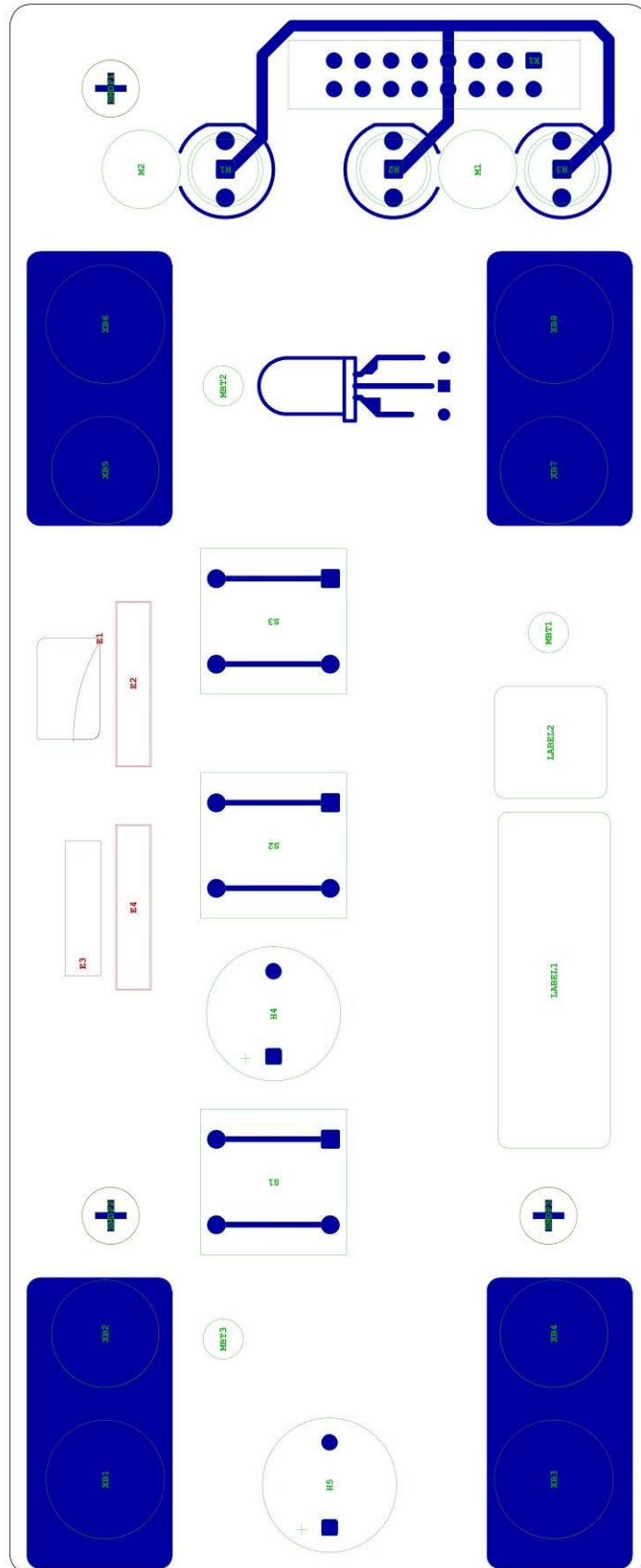

PCB SIBFS33_14

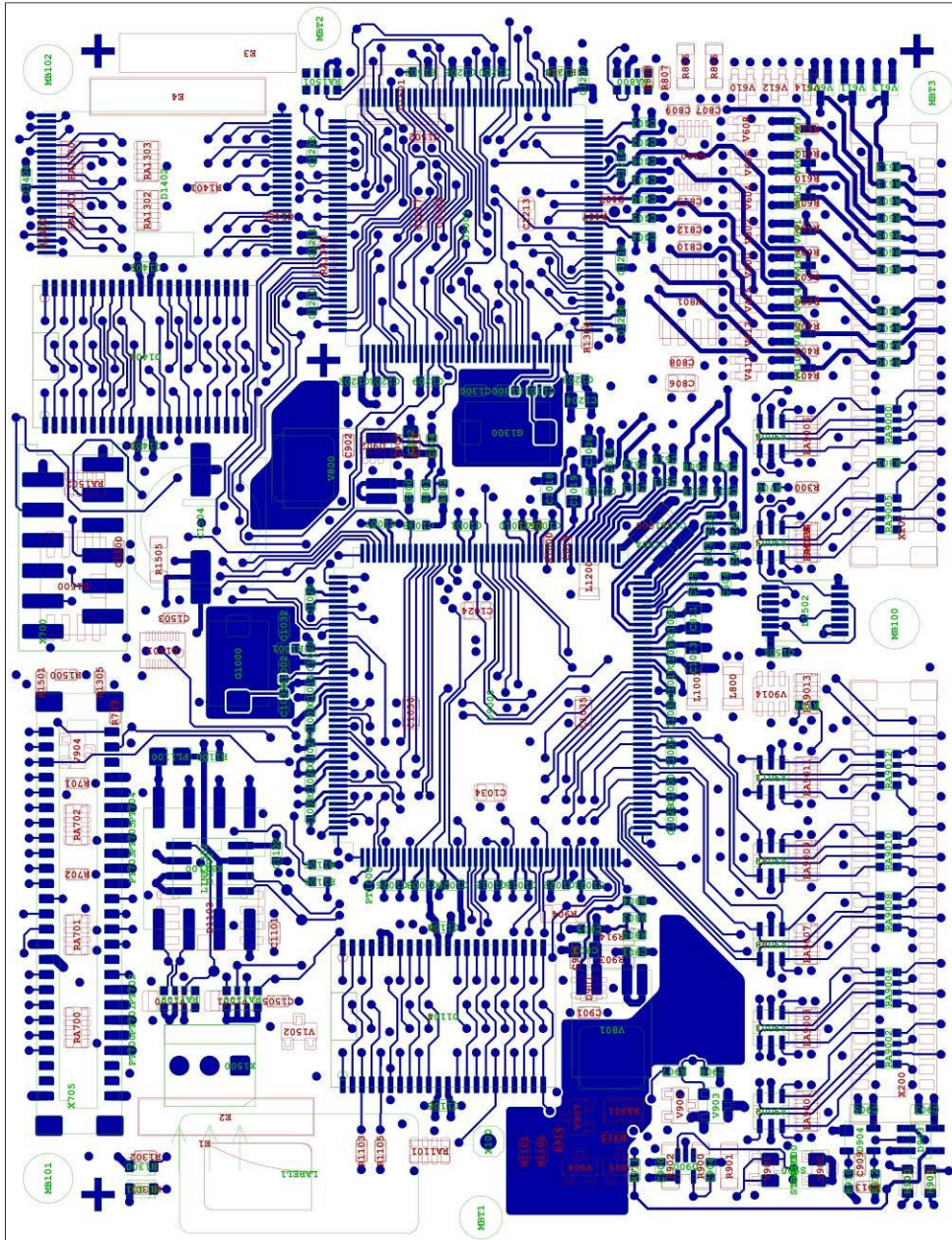

This document may not be copied or passed on to anyone. The contents of this document may not be made public to anyone, except with explicit written permission. Violations of this policy - especially those concerning patents and copyrights - are reserved. SMA Solar Technology AG - Sonnenallee 1 - D-31135 Hildesheim, Germany

Item of PCB	Item of Variant	Item of Connection	Department	Revision	Name
SMA Material: Hersteller: PCB	SIBFS33_14	Steckverbinder: AST	SMA Solar Technology AG	4	@revis
40-A017314	T.Plürring			3	
				2	
				1	

Item of Variant	Item of Connection	Department	Revision	Name
SIBFS33_14	Steckverbinder: AST	SMA Solar Technology AG	4	@revis
11/03/02			9	
			8	
			7	
			6	
			5	
			4	
			3	
			2	
			1	

Item of Variant	Item of Connection	Department	Revision	Name
SIBFS33_14	Steckverbinder: AST	SMA Solar Technology AG	4	@revis
11/03/02			9	
			8	
			7	
			6	
			5	
			4	
			3	
			2	
			1	

Item of Variant	Item of Connection	Department	Revision	Name
SIBFS33_14	Steckverbinder: AST	SMA Solar Technology AG	4	@revis
11/03/02			9	
			8	
			7	
			6	
			5	
			4	
			3	
			2	
			1	

Item of Variant	Item of Connection	Department	Revision	Name
SIBFS33_14	Steckverbinder: AST	SMA Solar Technology AG	4	@revis
11/03/02			9	
			8	
			7	
			6	
			5	
			4	
			3	
			2	
			1	

Item of Variant	Item of Connection	Department	Revision	Name
SIBFS33_14	Steckverbinder: AST	SMA Solar Technology AG	4	@revis
11/03/02			9	
			8	
			7	
			6	
			5	
			4	
			3	
			2	
			1	

Item of Variant	Item of Connection	Department	Revision	Name
SIBFS33_14	Steckverbinder: AST	SMA Solar Technology AG	4	@revis
11/03/02			9	
			8	
			7	
			6	
			5	
			4	
			3	
			2	
			1	

Item of Variant	Item of Connection	Department	Revision	Name
SIBFS33_14	Steckverbinder: AST	SMA Solar Technology AG	4	@revis
11/03/02			9	
			8	
			7	
			6	
			5	
			4	
			3	
			2	
			1	

Item of Variant	Item of Connection	Department	Revision	Name
SIBFS33_14	Steckverbinder: AST	SMA Solar Technology AG	4	@revis
11/03/02			9	
			8	
			7	
			6	
			5	
			4	
			3	
			2	
			1	

Item of Variant	Item of Connection	Department	Revision	Name
SIBFS33_14	Steckverbinder: AST	SMA Solar Technology AG	4	@revis
11/03/02			9	
			8	
			7	
			6	
			5	
			4	
			3	
			2	
			1	

Item of Variant	Item of Connection	Department	Revision	Name
SIBFS33_14	Steckverbinder: AST	SMA Solar Technology AG	4	@revis
11/03/02			9	
			8	
			7	
			6	
			5	
			4	
			3	
			2	
			1	

Item of Variant	Item of Connection	Department	Revision	Name
SIBFS33_14	Steckverbinder: AST	SMA Solar Technology AG	4	@revis
11/03/02			9	
			8	
			7	
			6	
			5	
			4	
			3	
			2	
			1	

Item of Variant	Item of Connection	Department	Revision	Name
SIBFS33_14	Steckverbinder: AST	SMA Solar Technology AG	4	@revis
11/03/02			9	
			8	
			7	
			6	
			5	
			4	
			3	
			2	
			1	

Item of Variant	Item of Connection	Department	Revision	Name
SIBFS33_14	Steckverbinder: AST	SMA Solar Technology AG	4	@revis
11/03/02			9	
			8	
			7	
			6	
			5	
			4	
			3	
			2	
			1	

Item of Variant	Item of Connection	Department	Revision	Name
SIBFS33_14	Steckverbinder: AST	SMA Solar Technology AG	4	@revis
11/03/02			9	
			8	
			7	
			6	
			5	
			4	
			3	
			2	
			1	

Item of Variant	Item of Connection	Department	Revision	Name
SIBFS33_14	Steckverbinder: AST	SMA Solar Technology AG	4	@revis
11/03/02			9	
			8	
			7	
			6	
			5	
			4	
			3	
			2	
			1	

Item of Variant	Item of Connection	Department	Revision	Name
SIBFS33_14	Steckverbinder: AST	SMA Solar Technology AG	4	@revis
11/03/02			9	
			8	
			7	
			6	
			5	
			4	
			3	
			2	
			1	

Item of Variant	Item of Connection	Department	Revision	Name
SIBFS33_14	Steckverbinder: AST	SMA Solar Technology AG	4	@revis
11/03/02			9	
			8	
			7	
			6	
			5	
			4	
			3	
			2	
			1	

Item of Variant	Item of Connection	Department	Revision	Name
SIBFS33_14	Steckverbinder: AST	SMA Solar Technology AG	4	@revis
11/03/02			9	
			8	
			7	
			6	
			5	
			4	
			3	
			2	
			1	

Item of Variant	Item of Connection	Department	Revision	Name
SIBFS33_14	Steckverbinder: AST	SMA Solar Technology AG	4	@revis
11/03/02			9	
			8	
			7	
			6	
			5	
			4	
			3	
			2	
			1	

Item of Variant	Item of Connection	Department	Revision	Name
SIBFS33_14	Steckverbinder: AST	SMA Solar Technology AG	4	@revis
11/03/02			9	
			8	
			7	
			6	
			5	
			4	
			3	
			2	
			1	

Item of Variant	Item of Connection	Department	Revision	Name
SIBFS33_14	Steckverbinder: AST	SMA Solar Technology AG	4	@revis
11/03/02			9	
			8	
			7	
			6	
			5	
			4	
			3	
			2	
			1	

Item of Variant	Item of Connection	Department	Revision	Name
SIBFS33_14	Steckverbinder: AST	SMA Solar Technology AG	4	@revis
11/03/02			9	
			8	
			7	
			6	
			5	
			4	
			3	
			2	
			1	

Item of Variant	Item of Connection	Department	Revision	Name
SIBFS33_14	Steckverbinder: AST	SMA Solar Technology AG	4	@revis
11/03/02			9	
			8	
			7	
			6	
			5	
			4	
			3	
			2	
			1	

Item of Variant	Item of Connection	Department	Revision	Name
SIBFS33_14	Steckverbinder: AST	SMA Solar Technology AG	4	@revis
11/03/02			9	
			8	
			7	
			6	
			5	
			4	
			3	
			2	
			1	

Item of Variant	Item of Connection	Department	Revision	Name
SIBFS33_14	Steckverbinder: AST	SMA Solar Technology AG	4	@revis
11/03/02			9	
			8	
			7	
			6	
			5	
			4	
			3	
			2	
			1	

Item of Variant	Item of Connection	Department	Revision	Name
SIBFS33_14	Steckverbinder: AST	SMA Solar Technology AG	4	@revis
11/03/02			9	
			8	
			7	
			6	
			5	
			4	
			3	
			2	
			1	

Item of Variant	Item of Connection	Department	Revision	Name
SIBFS33_14	Steckverbinder: AST	SMA Solar Technology AG	4	@revis
11/03/02			9	
			8	
			7	
			6	

This document may not be copied or passed on to anyone. The contents of this document may not be made public to anyone, except with specific written permission. Violations of this document, especially those concerning patents and copyrights, are reserved. SMA Solar Technology AG Sonnenallee 1, D-71634 Metzingen, Germany

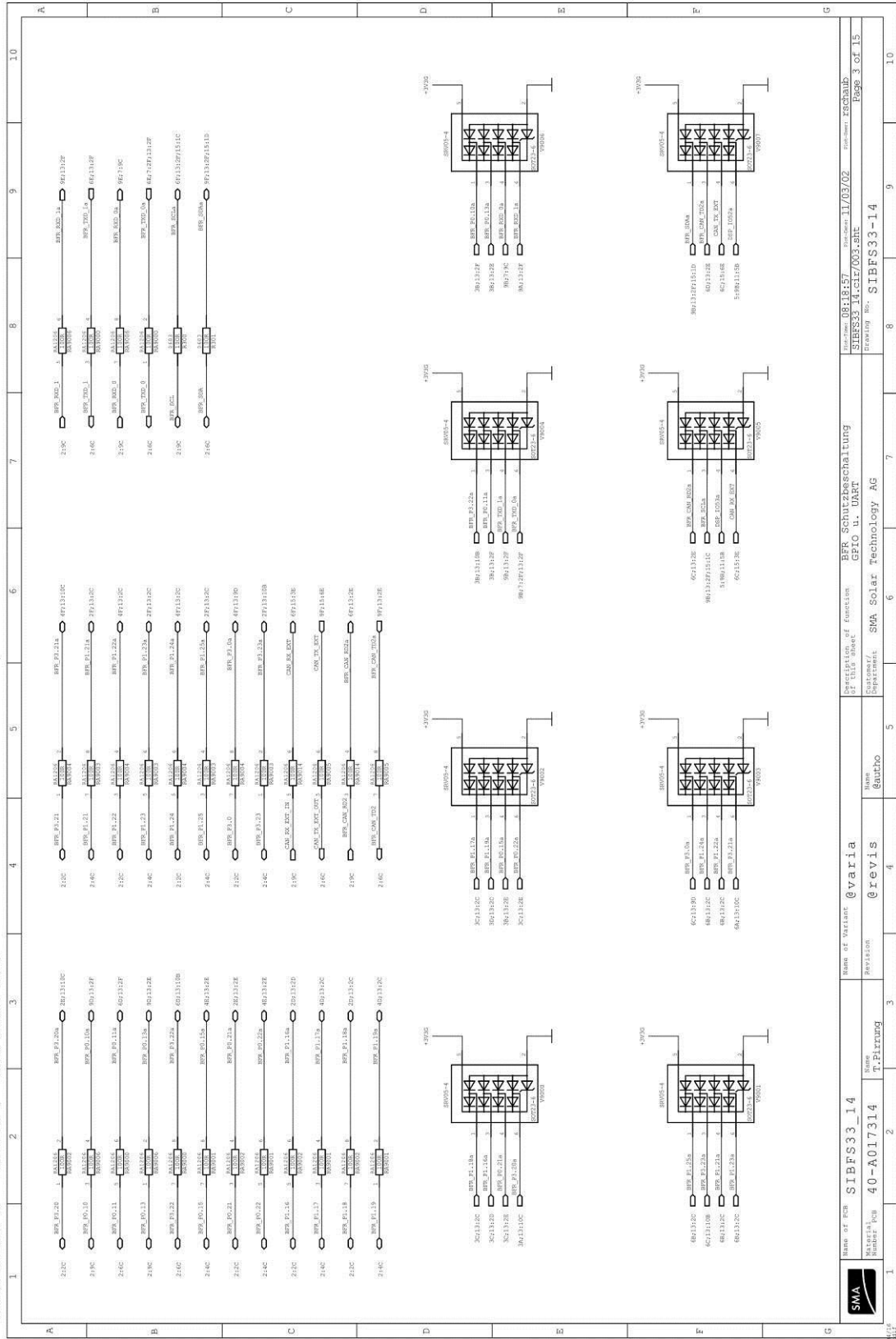

This document may not be copied or passed on to anyone. The contents of this document may not be made public to anyone, except with explicit written permission. Violations will result in legal action. All rights - especially those concerning patents and copyrights - are reserved. SMA Solar Technology AG Sonnenallee 1 42799 Solingen GERMANY

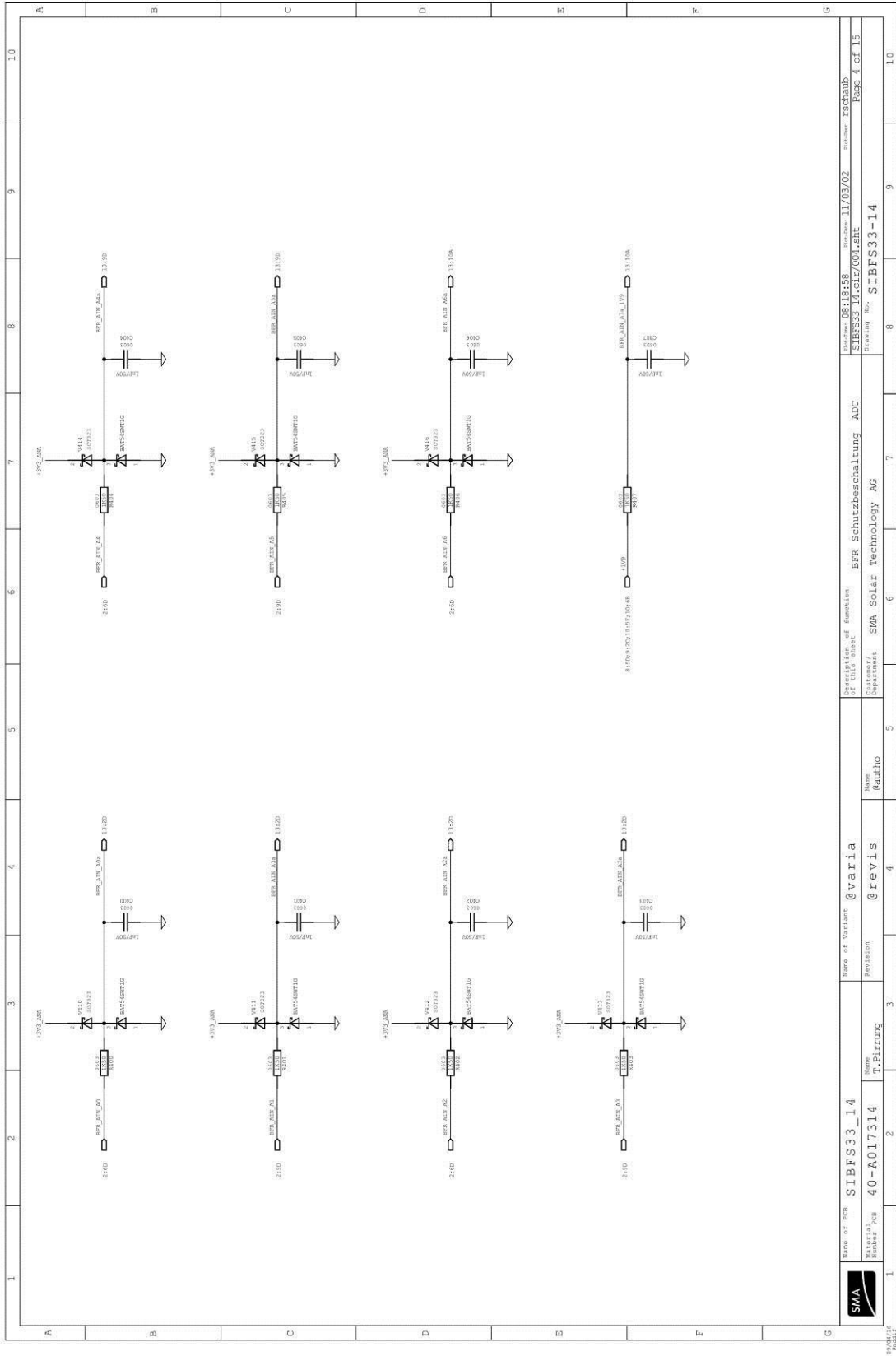

Item of PCB SIBFS33_14	Name of Variant @varia	Number of Execution of this Block BFR_Schutzbeschaltung_ADC	Revision @revis	Revision @autro	Department SMA Solar Technology AG	Drawn SIBFS33-14	Checked SIBFS33-14	Date 11/03/02	Page 4 of 15
---------------------------	---------------------------	---	--------------------	--------------------	---------------------------------------	---------------------	-----------------------	------------------	-----------------

This document may not be copied or passed on to anyone. The contents of this document may not be made public to anyone except with explicit written permission. Violations of this document may result in legal action. All rights reserved. SMA Solar Technology AG - Sonnenteile 1 - 37106 Hildesheim, Germany

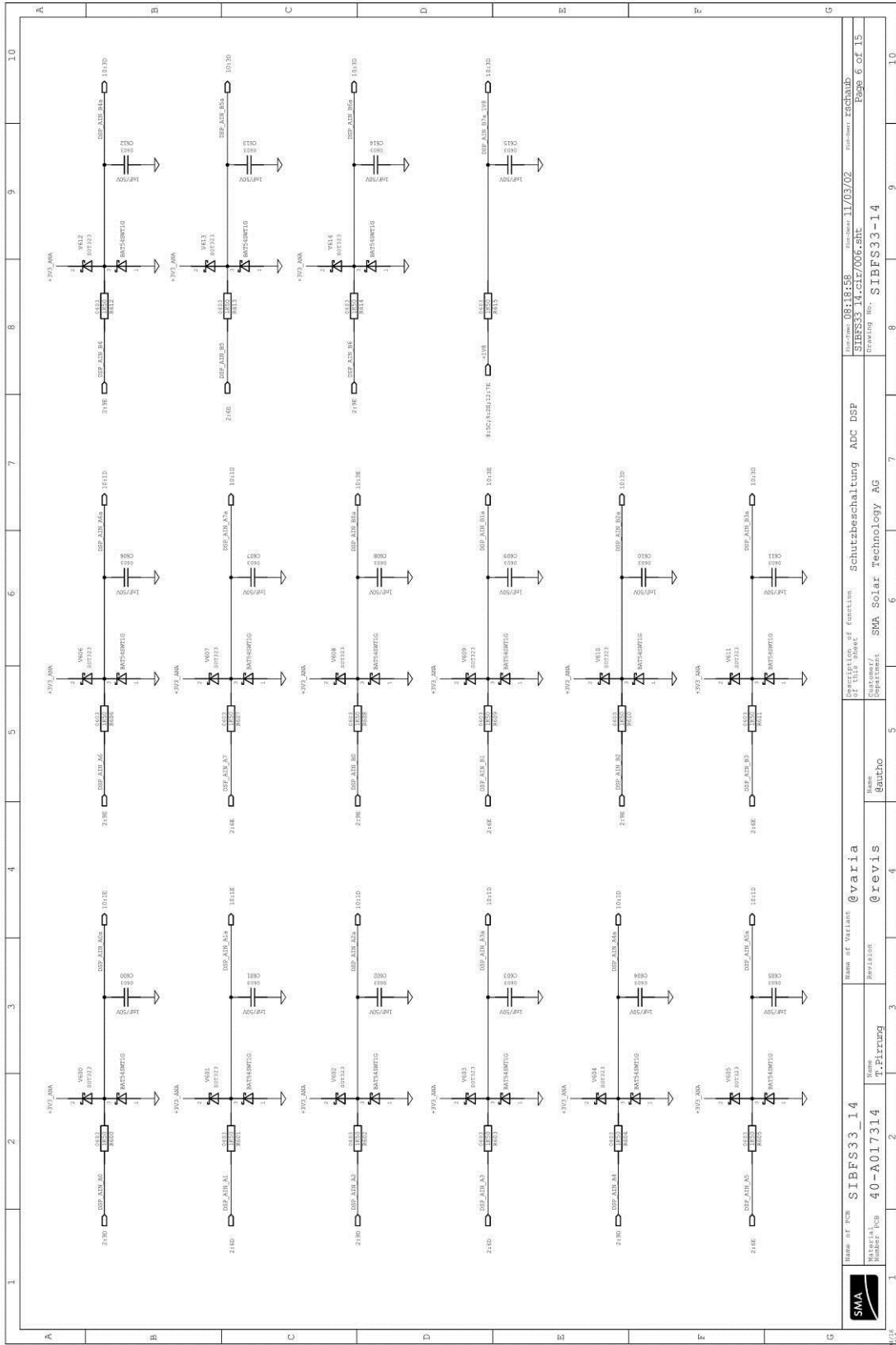

Item of PCB	SIBFS33_14	Name of Variant	@varia	Department	SMA Solar Technology AG
Material Number PCB	40-A017314	Name	T.Pfurring	Department	SMA Solar Technology AG
		Revision	@revis	Department	SMA Solar Technology AG
				Department	SMA Solar Technology AG
				Department	SMA Solar Technology AG
				Department	SMA Solar Technology AG
				Department	SMA Solar Technology AG
				Department	SMA Solar Technology AG
				Department	SMA Solar Technology AG
				Department	SMA Solar Technology AG
				Department	SMA Solar Technology AG

This document may not be copied or passed on to anyone. The contents of this document may not be made public to anyone, except with explicit written permission. Violations will result in legal action. All rights - especially those concerning patents and copyrights - are reserved. SMA Solar Technology AG Sonnenallee 1 42106 Solingen GERMANY

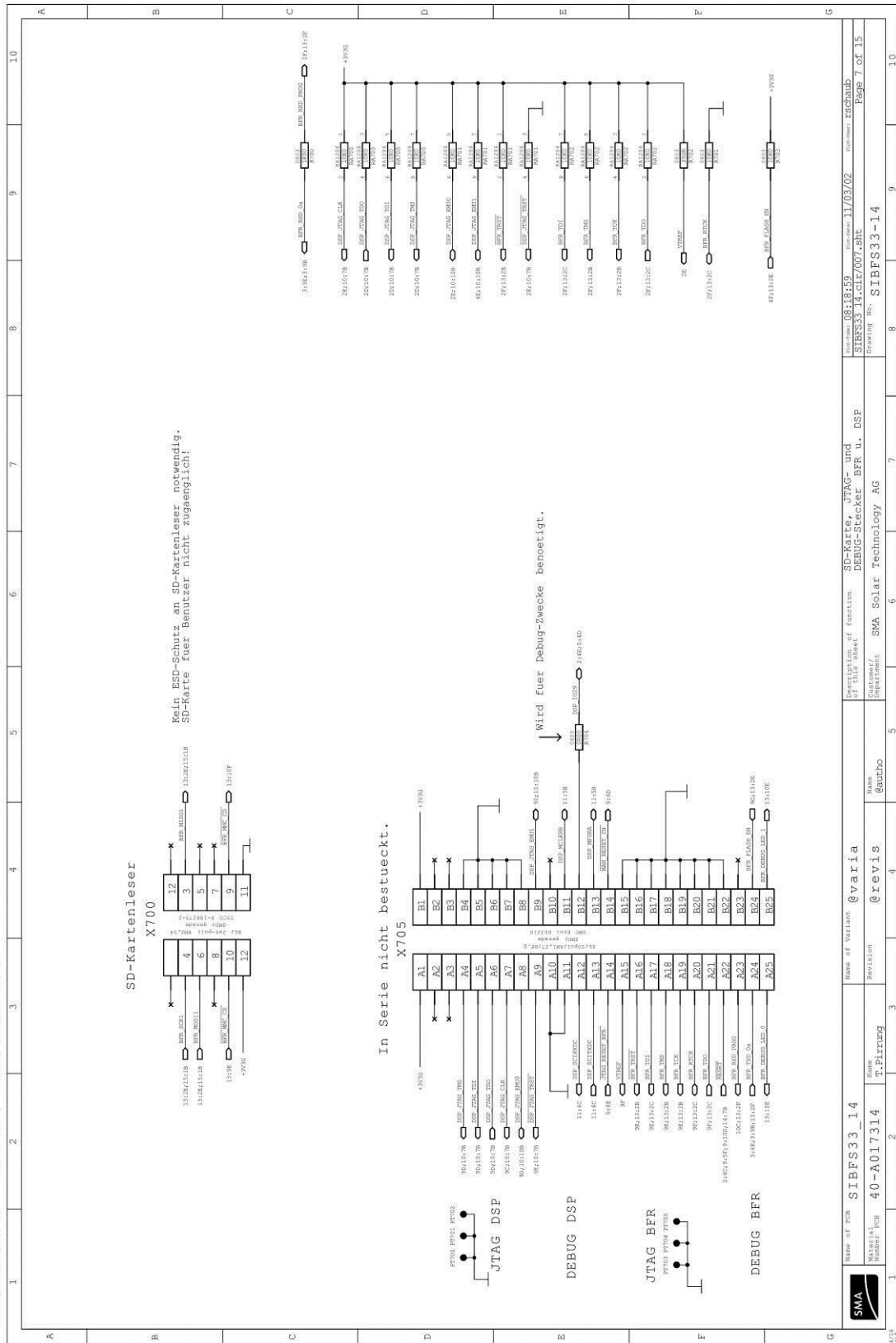

This document may not be copied or passed on to anyone. The contents of this document may not be made public in any way, except with explicit written permission. Violations of copyright law will be prosecuted. All rights reserved. SMA Solar Technology AG

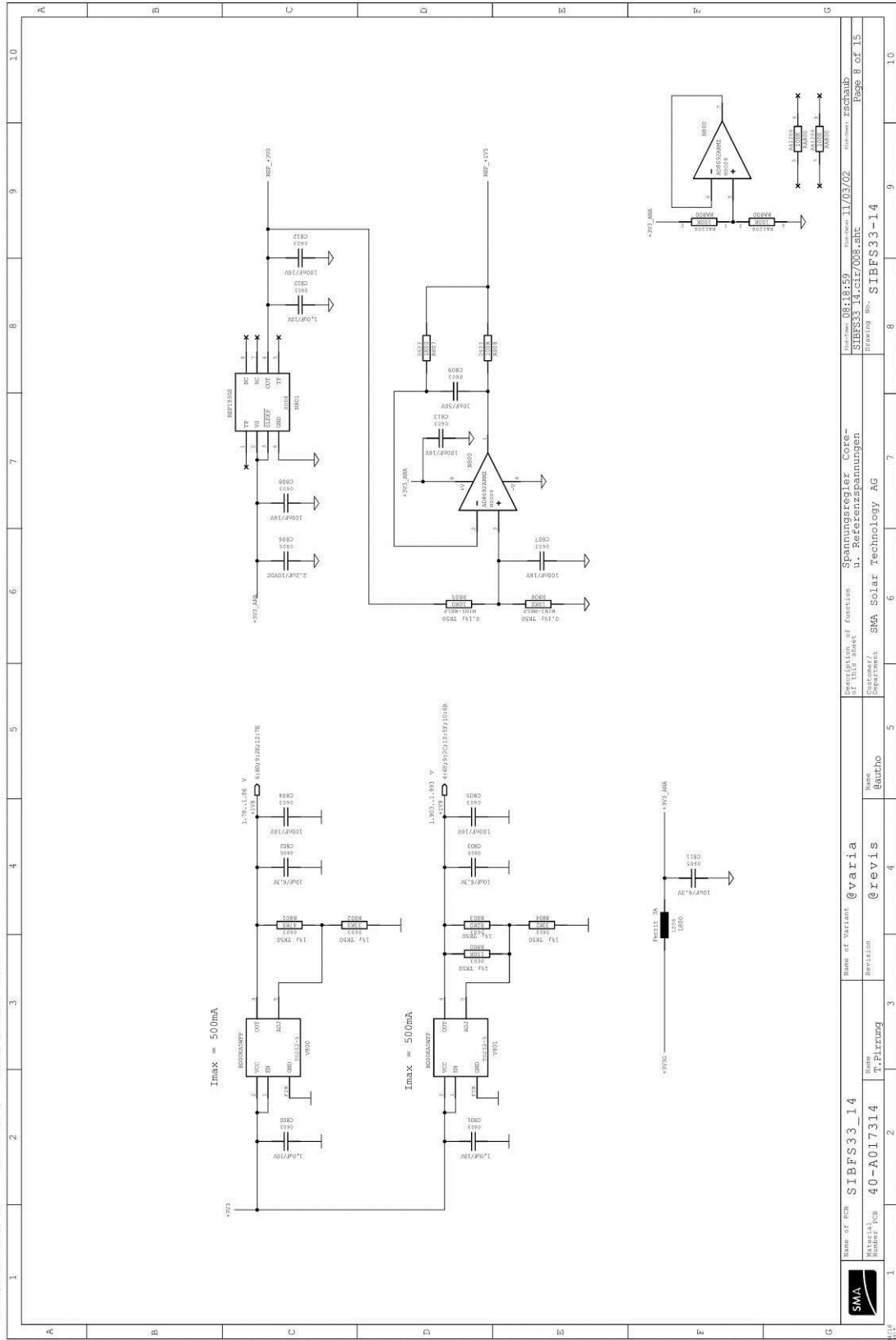

Item of PCB	SIBFS33_14	Name of Variant	@varia	Name	@autro
Material Number PCB	40-A017314	Name	T.Pfarrung	Revision	
Material No.	SIBFS33-14	Department	SMA Solar Technology AG	Department	
Material No.	SIBFS33-14	Department	SMA Solar Technology AG	Department	
Material No.	SIBFS33-14	Department	SMA Solar Technology AG	Department	
Material No.	SIBFS33-14	Department	SMA Solar Technology AG	Department	
Material No.	SIBFS33-14	Department	SMA Solar Technology AG	Department	
Material No.	SIBFS33-14	Department	SMA Solar Technology AG	Department	
Material No.	SIBFS33-14	Department	SMA Solar Technology AG	Department	
Material No.	SIBFS33-14	Department	SMA Solar Technology AG	Department	
Material No.	SIBFS33-14	Department	SMA Solar Technology AG	Department	

This document may not be copied or passed on to anyone. The contents of this document may not be made public to anyone, except with specific written permission. Violations of this policy - especially those concerning patents and copyrights - are reserved. SMA Solar Technology AG Sonnenschein 1 52106 Bielefeld GERMANY

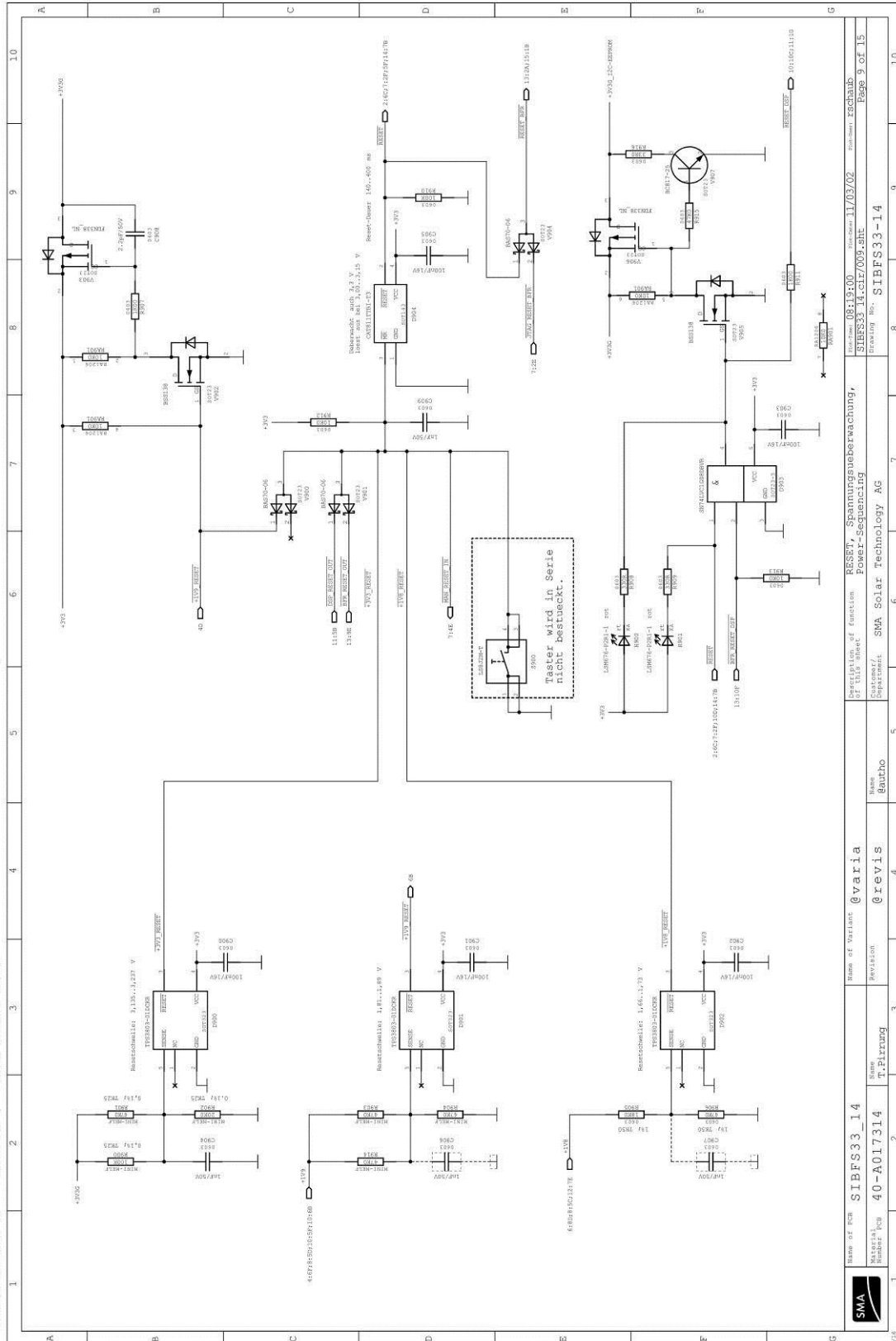

Item of PCB	SIBFS33_14	Name of Variant	@varia
Material Number PCB	40-A017314	Name	@revis
		Revision	
		Department	SMA Solar Technology AG
		Drawn	SIBFS33-14
		Checked	
		Approved	
		Date	11/03/02
		Page	9 of 15

This document may not be copied or passed on to anyone. The contents of this document may not be made public to anyone except with explicit written permission. Violations will be prosecuted. All rights reserved. SMA Solar Technology AG - Sonnensysteme 1 - P-2106 Industriestrasse 26/28/30

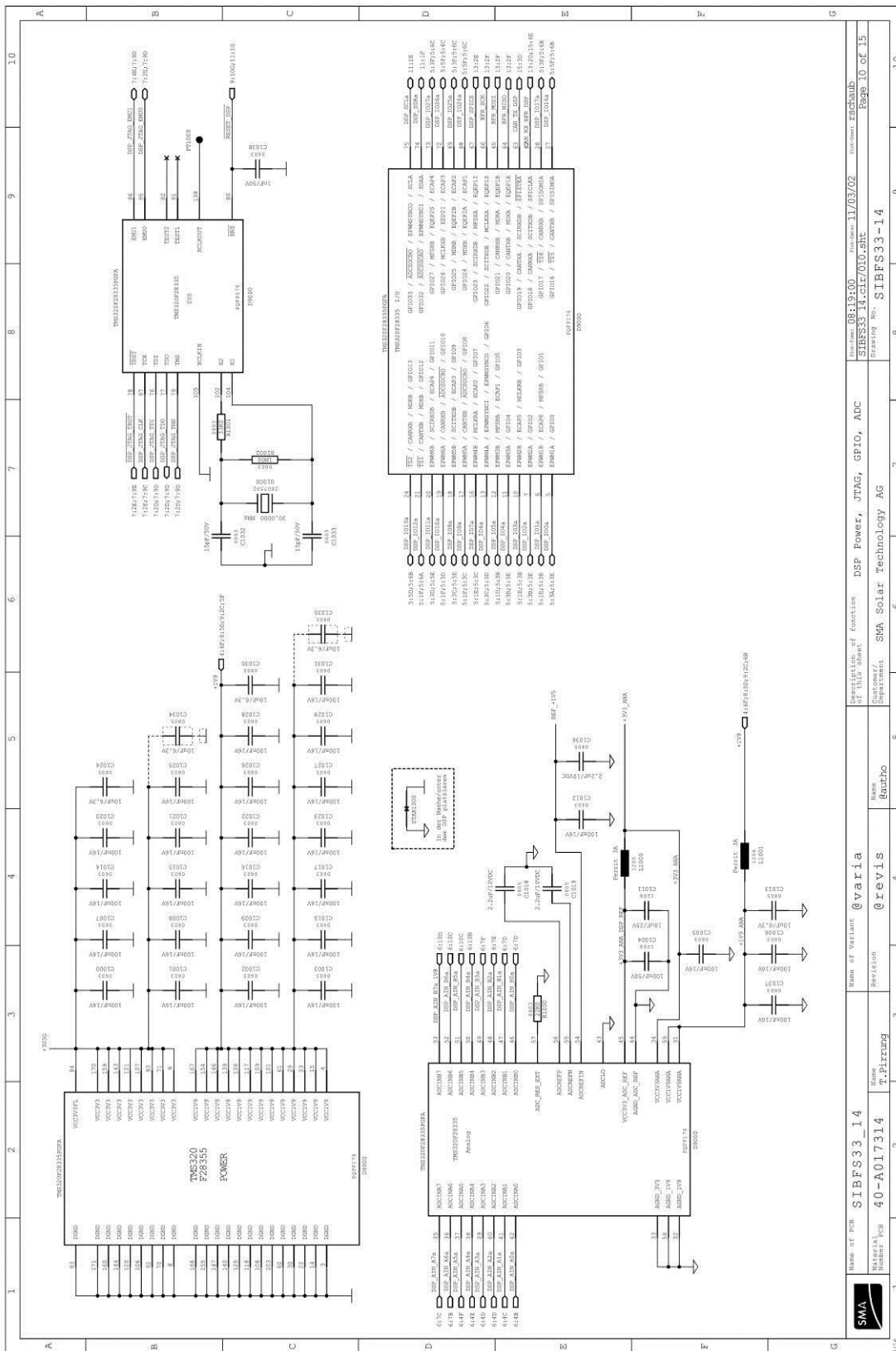

This document may not be copied or passed on to anyone. The contents of this document may not be made public to anyone except with explicit written permission. Violations of this document may result in legal action. All rights - especially those concerning patents and copyrights - are reserved. SMA Solar Technology AG - Sonnentechnik | P-Office Industrielle Zone

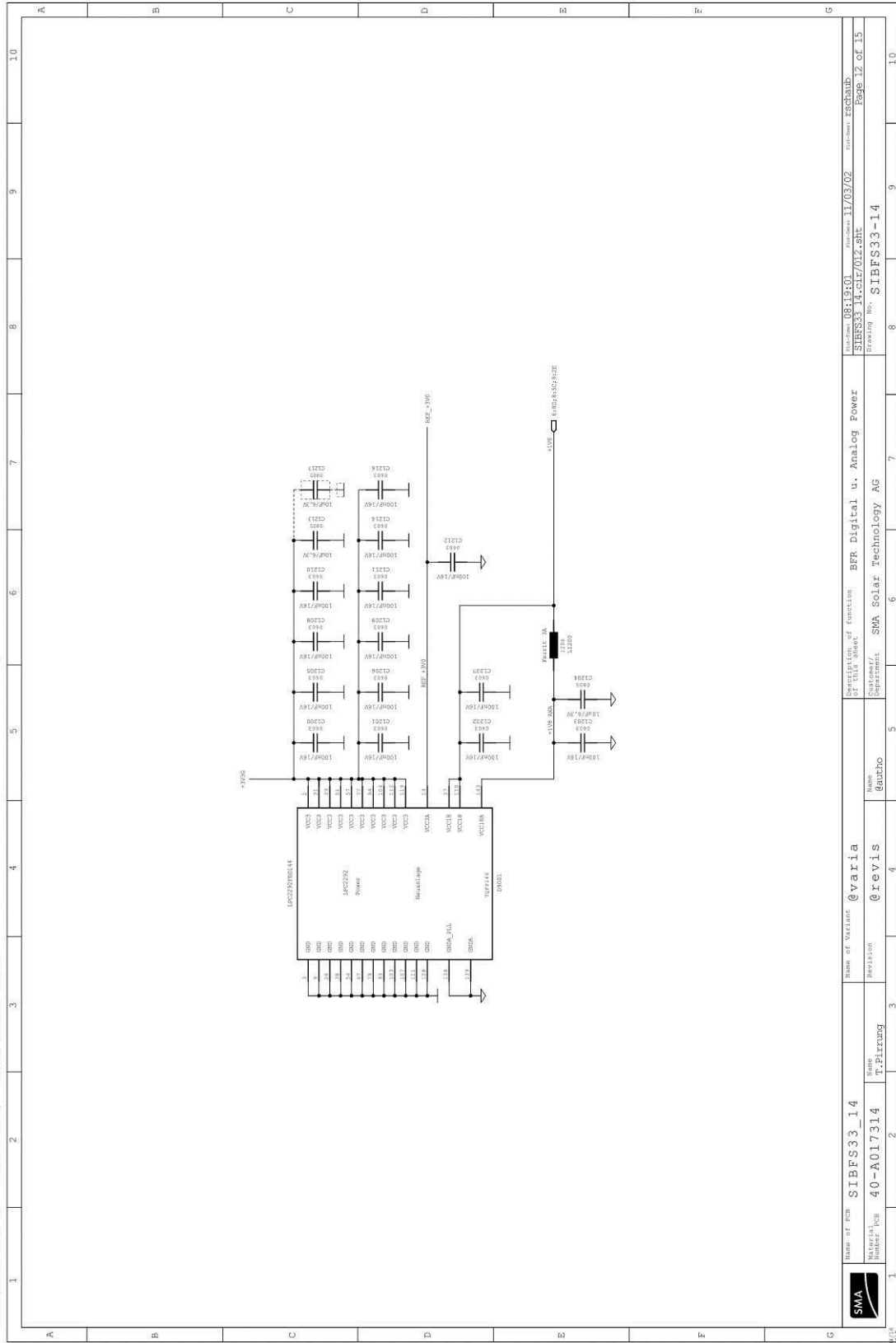

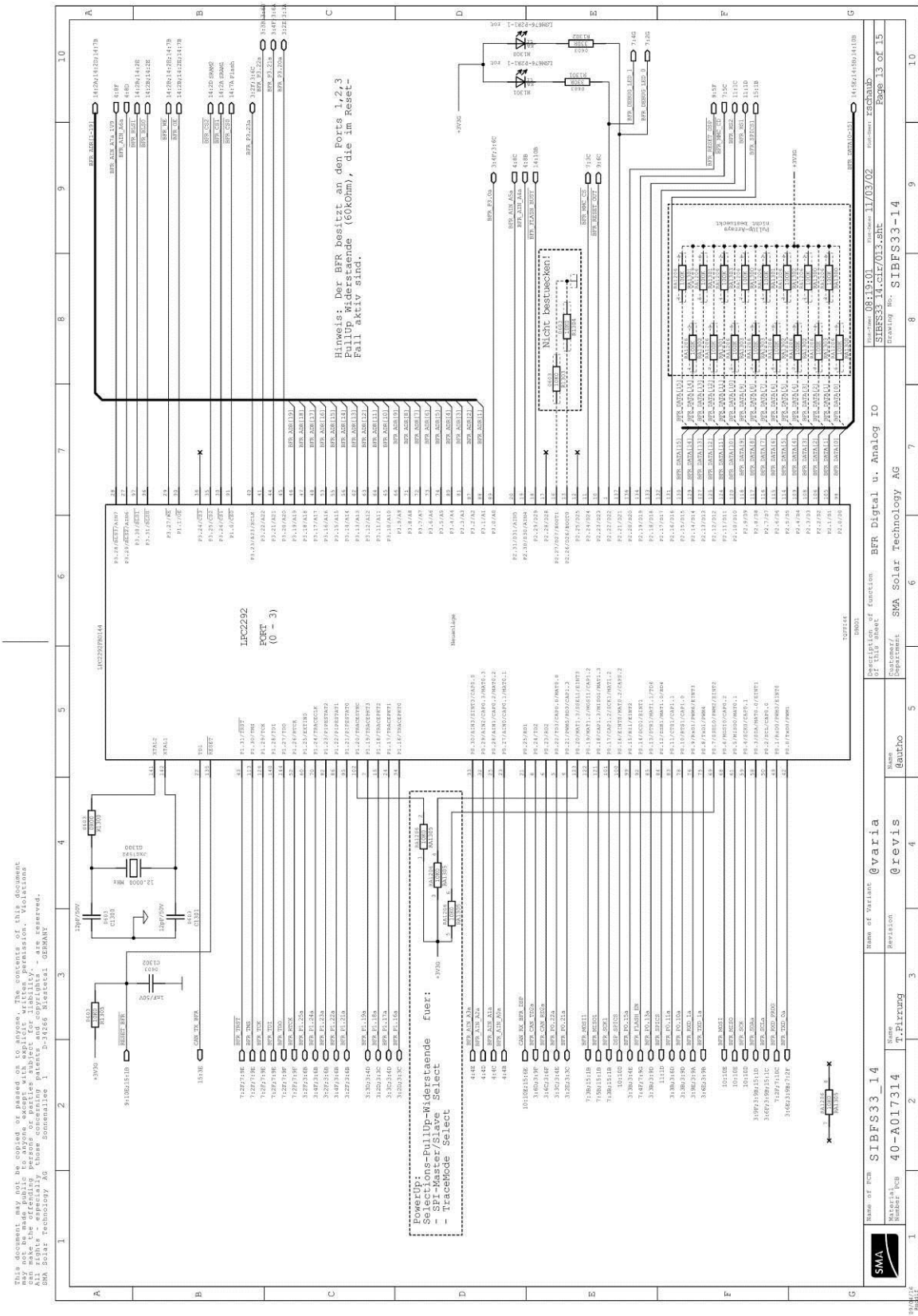

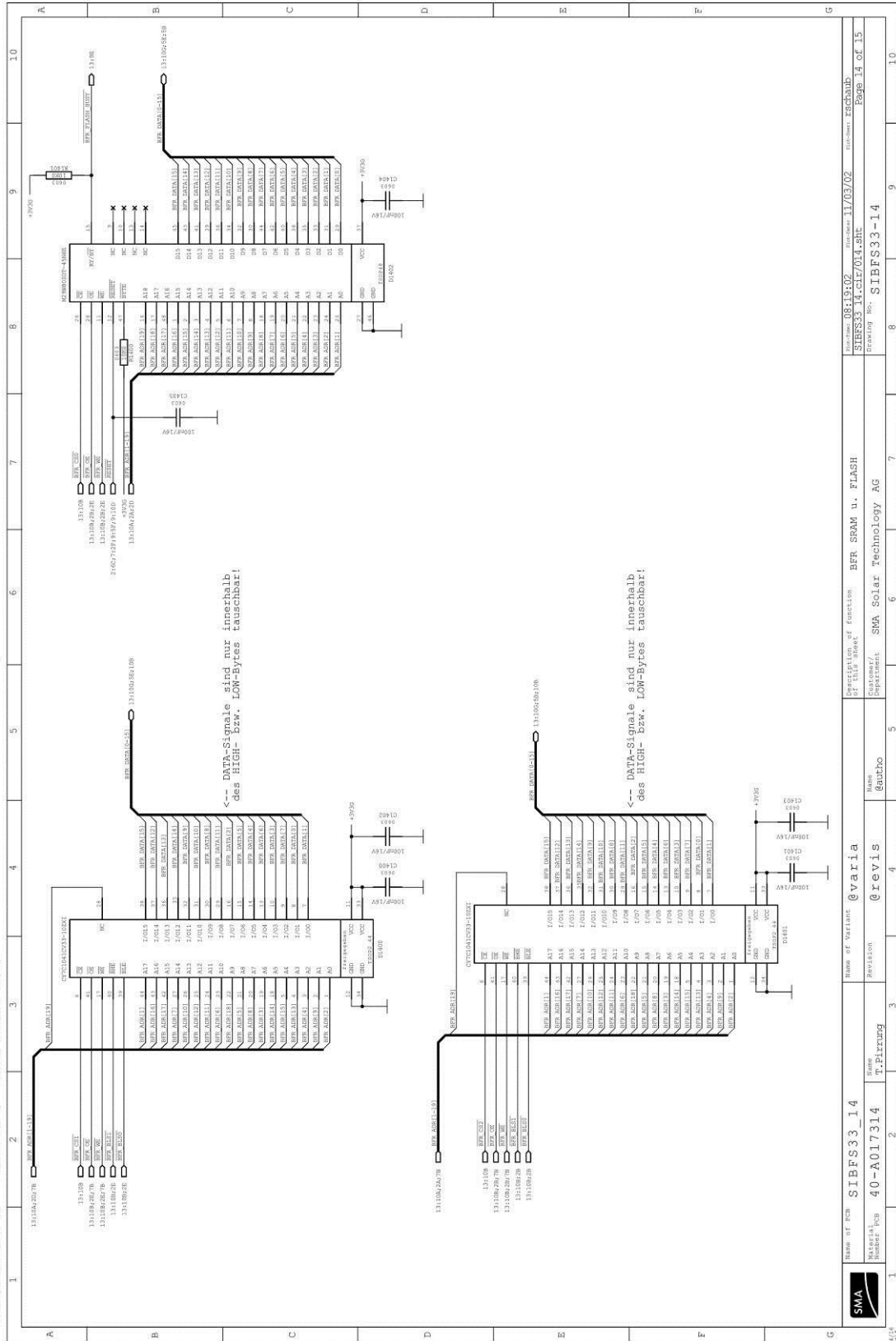

This document may not be copied or passed on to anyone. The contents of this document may not be made public to anyone except with explicit written permission. Violations will be prosecuted. All rights - especially those concerning patents and copyrights - are reserved. SMA Solar Technology AG Sonnenallee 1 42106 Solingen GERMANY

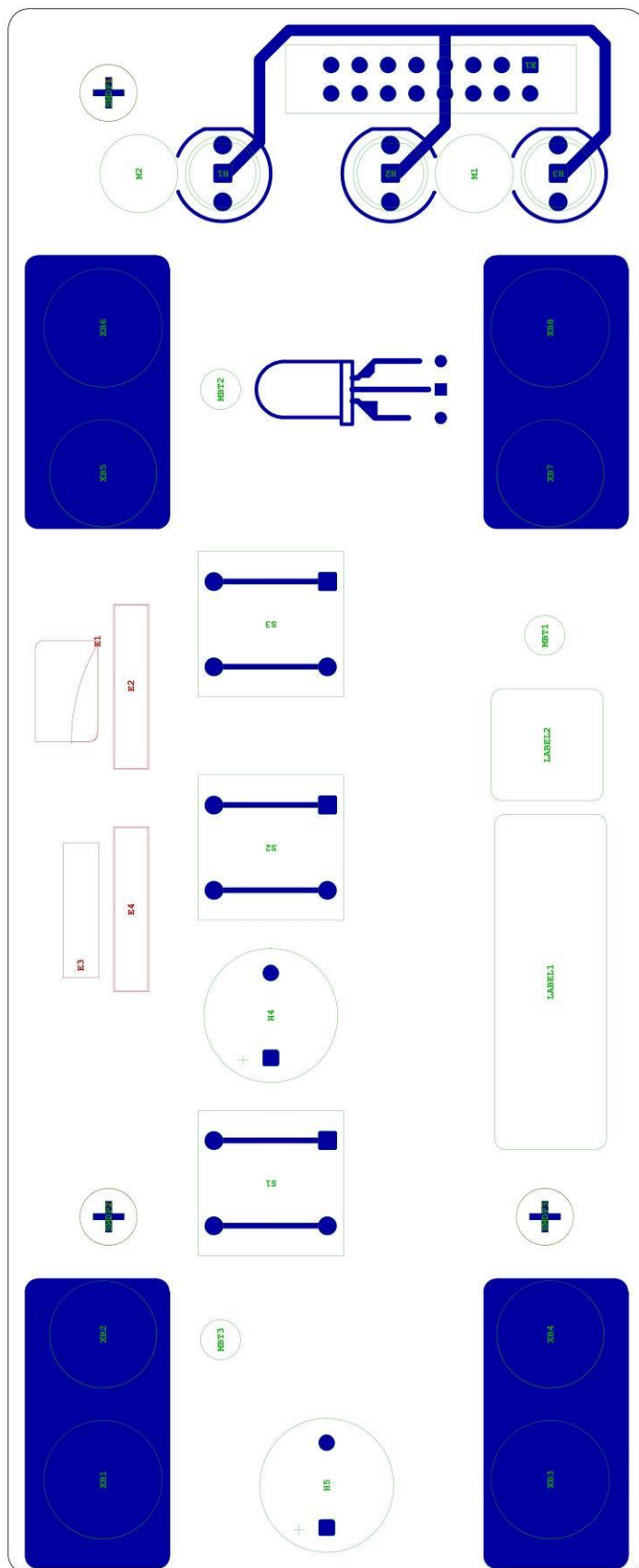

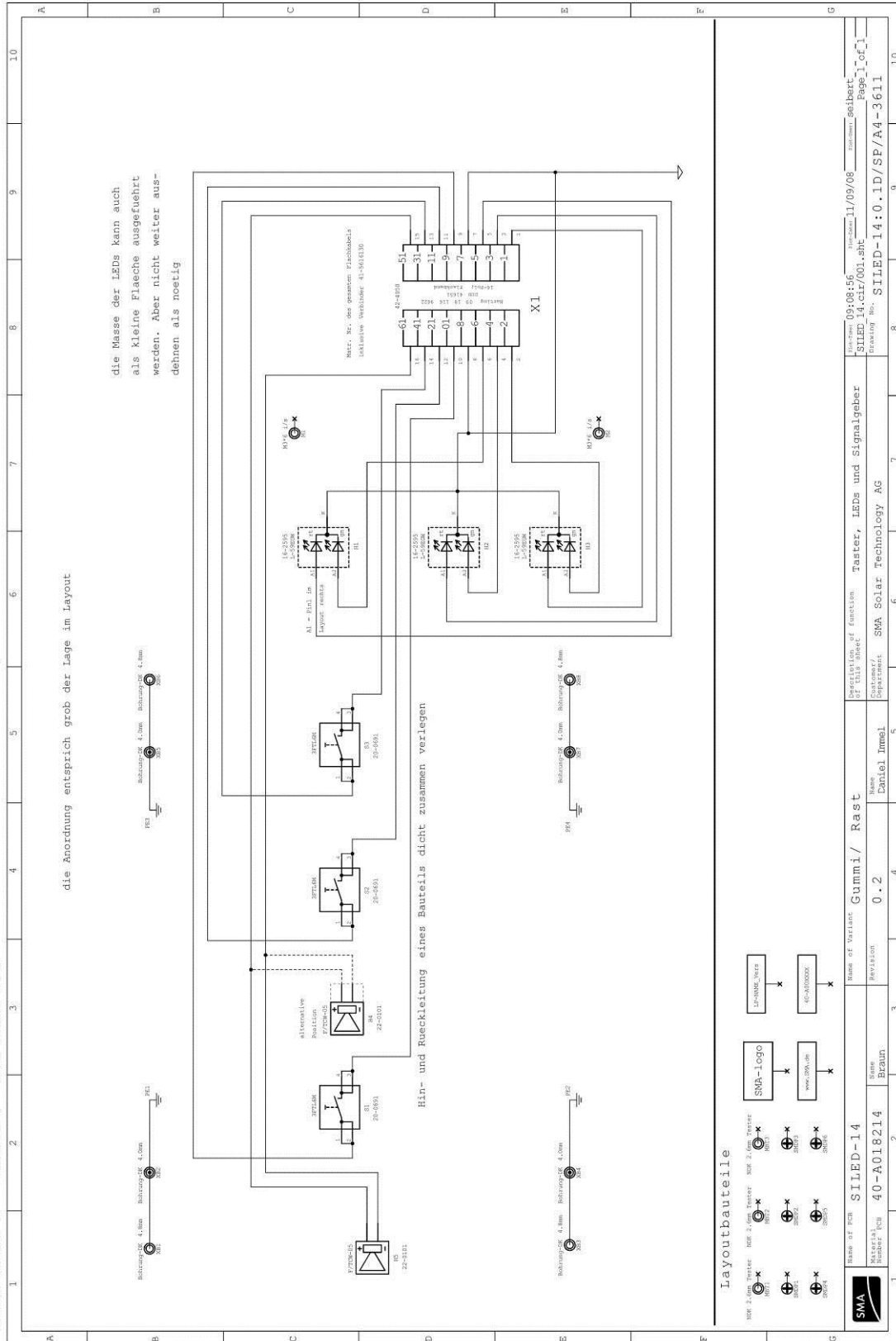

This document may not be copied or based on to anyone. The contents of this document may not be made public to anyone except with explicit written permission. Violations of this document may result in legal action. All rights reserved. SMA Solar Technology AG. SMA Solar Technology AG. SMA Solar Technology AG. SMA Solar Technology AG.



	Product Specification	64-113200.01
	PowerTransformer Block	PS/dtw/2230
	26V / 230V 50Hz - 1650VA (3200VA) with 120µH smoothing choke and integrated current transformer	issue: 01 2014-09-04 page: 1 pages: 9

dtw sp. z o.o.
ul. Krakowska 390, 32-080 Zabierzów, Poland
tel.: +48 12 283 09 50 , fax: +48 12 285 35 67
dtw@dtw.com.pl

Manufacturer

SMA Solar Technology AG
Sonnenallee 1 , D-34266 Niestetal , Germany
tel.: +49 561 95 22 0 , fax: +49 561 95 22 100

Customer

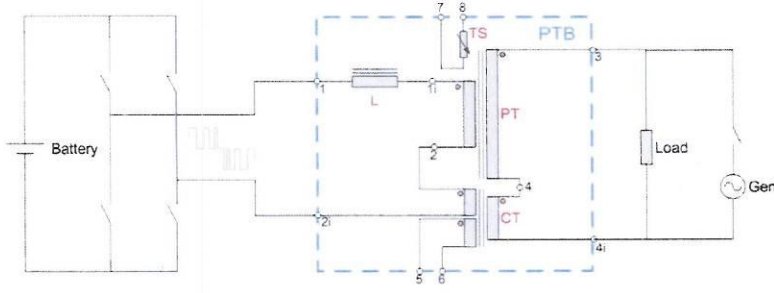
1	Product name	Power Transformer Block 1650PTB2230 Toroidal Safety Isolating Transformer: 26V / 230V (50Hz) ; 1650VA (3200VA) Smoothing choke: $L_1 = 120\mu\text{H}$ (20kHz) (integrated in PRI circuit) Current transformer: turn ratio 1:9:2000 (integrated in PRI and SEC circuit)
2	 <p>Fig.1</p>	
3	Classifications	according to: EN 61558-1 , EN 61558-2-4
3.1	Acc. to the intended use	Incorporated Power Transformer An associated transformer and integrated chokes that are designed to be built into inverter.
3.2	Acc. to their protection against electric shock	Construction as for class II transformers. The parts of the Power Transformer Block's housing accessible at the air outlet and accessible during exchange of the fan, if properly mounted the inverter construction provides the protection against electrical shock.
3.3	Acc. to short-circuit protection or abnormal use	Non-short-circuit proof transformers.
3.4	Acc. to the degree of protection ensured by the enclosure	IP54 - obtained after being built into inverter
3.5	Acc. to their mobility	Fixed transformers and chokes.
3.6	Acc. to their time of operation	Continuous operation.
3.7	Acc. RoHS directive	This product is in accordance with RoHS directive 2011/65/EC.
4	Types	
4.1	SMA type / SMA part no.	64-113200.01
4.2	Manufacturer type	1650PTB2230

Jakub Hachlowski
approved by manufacturer

11.09.2014
date

i.A. K. B.
approved by SMA

12.09.14
date

PS/dtw/2230_04-06756

© 2014 dtw sp. z o.o. All Rights Reserved

	Product Specification		64-113200.01	
	PowerTransformer Block		PS/dtw/2230	
	26V / 230V 50Hz - 1650VA (3200VA) with 120µH smoothing choke and integrated current transformer		issue: 01	2014-09-04
			page: 2	pages: 9

5	Technical data (electrical, environmental, other) – Power Transformer PT			Notes
5.1	Circuits	PRI	SEC	
5.2	Windings	1i – 2	3 – 4	
5.3	Rated supply voltage	25,56V _{rms}	-	
5.4	Rated frequency	50Hz		
5.5	Rated output voltage	-	230V _{rms}	
5.6	Rated output	1650VA @ 230V _{rms} @ passive cooling, @ Ta = 25°C		
5.7	Overload output	3200VA @ 230V _{rms} @ forced cooling, @ Ta = 25°C		on the conditions 12.1
5.8	Overload output short time operation	4400VA @ 230V _{rms} @ 30min short time rating @ forced cooling, @ Ta = 25°C		on the conditions 12.1
5.9	No-load output voltage	25,4 – 26,65V _{rms}	Supply 230V _{rms}	100% tested
5.10	Saturation	U _{3.4} = 275V _{rms} (50Hz) P _{fe} ≤ 12W		type test
5.11	No-load core losses	P _{fe} ≤ 8W @ U _{3.4} = 230V _{rms} (50Hz)		100% tested
5.12	Winding resistances	≤ 5,65mΩ	≤ 460mΩ	100% tested, Ta = T _{cu} = 20°C
5.13	Rated ambient temperature	Ta = -25°C to +60°C		
5.14	Insulation class	B (130°C)		
5.15	Dielectric strength between	between PRI and SEC - 4000V _{AC} (50Hz)		(1s) Final test 100%

approved by manufacturer

11.09.2014
date

approved by SMA

12.09.14
date

PS/dtw/2230_04-06756

© 2014 dtw sp. z o.o. All Rights Reserved

	Product Specification	64-113200.01			
	Power Transformer Block	PS/dtw/2230			
	26V / 230V 50Hz - 1650VA (3200VA) with 120µH smoothing choke and integrated current transformer	<table border="1"> <tr> <td>issue: 01</td> <td>2014-09-04</td> </tr> <tr> <td>page: 3</td> <td>pages: 9</td> </tr> </table>	issue: 01	2014-09-04	page: 3
issue: 01	2014-09-04				
page: 3	pages: 9				

6	Technical data (electrical, environmental, other) – Smoothing Choke L		Notes
6.1	Circuits	1 - 1i	
6.2	Initial inductance	$L_0 = 120\mu\text{H}$ (+20% / -20%)	100% tested @ 300mV, 10kHz sinus voltage
6.3	Rated current	$I_L = 64,55\text{A}_{\text{rms}}$ (50Hz)	
6.4	Max. current	$I_L = 169,2\text{A}_{\text{rms}}$ (50Hz) @ forced cooling . @ $T_a = 25^\circ\text{C}$	on the conditions 12.1
6.5	Modulation	Unipolar	Three level modulation
6.6	Modulation Frequency	$f_{\text{mod}} = 20\text{kHz}$	
6.7	Input DC Voltage	$V_{\text{dc}} = 40\text{V}_{\text{DC}} - 65\text{V}_{\text{DC}}$	
6.8	Winding Resistance	$R_{\text{cu}} \leq 5,65\text{m}\Omega$ *	* integrated in PRI winding 100% tested, $T_a = T_{\text{cu}} = 20^\circ\text{C}$
6.9	Rated ambient temperature	$T_a = -25^\circ\text{C}$ to $+60^\circ\text{C}$	
6.10	Insulation class	B (130°C)	
6.11	Dielectric strength	Final test after potting acc. to 5.16	

7	Technical data (electrical, environmental, other) – Current Transformer CT		Notes
7.1	Circuits	2 - 2i, 4 - 4i, 5 - 6	Current transformer built into power transformer block Polarity 100% tested
7.2	Turns Ratio	1 : 9 : 2000 (± 10)	100% tested
7.3	Rated continuous thermal current	315Arms (50Hz, input 2 - 2i) 35Arms (50Hz, input 4 - 4i)	
7.4	Rated Output Voltage	0,315V	@63A input1, 7A input2, 10Ω load
7.5	Max. current	$I_{\text{CT}} = 0,4\text{A}_{\text{rms}}$ (50Hz)	when PT core saturated
7.6	Winding Resistance	$R_{\text{cu}} \leq 125\Omega$ (+2%)	100% tested, $T_a = 20^\circ\text{C}$
7.7	DC current tolerance	45Arms (50Hz, input 2 - 2i) or 5Arms (50Hz, input 4 - 4i)	With max. errors: - amplitude 50% - phase 60°
7.8	Insulation class	B (130°C)	
7.9	Dielectric strength	between SEC and CT - 4000V _{AC} (50Hz) between PRI and CT - 4000V _{AC} (50Hz)	(1s) Final test 100%

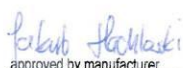
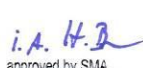
 approved by manufacturer
 11.09.2014 date
  approved by SMA
 12.09.14 date
 PS/dtw/2230_04-06756
 © 2014 dtw sp. z o.o. All Rights Reserved

	Product Specification		64-113200.01	
	Power Transformer Block		PS/dtw/2230	
	26V / 230V 50Hz - 1650VA (3200VA) with 120µH smoothing choke and integrated current transformer		issue: 01	2014-09-04
		page: 4	pages: 9	

8	Technical data (electrical, environmental, other) - Thermal Sensors TS		Notes
8.1	Circuits	7 - 8	Sensor placed between PRI and SEC winding
8.2	Sensor Resistance	$R_{25} = 2000 \Omega (\pm 1\%) @ T_a = 25^\circ\text{C}$	100% tested R_{20} , $T_a = 20^\circ\text{C}$
8.3	Sensor Ambient Temperature	$T_{a_sen} = -55^\circ\text{C}$ to $+150^\circ\text{C}$	
8.4	Type	KTY82/210 NXP	
8.5	Dielectric strength	between PRI and sensors TS - 4000V _{AC} (50Hz) between SEC and sensors TS - 4000V _{AC} (50Hz)	(1s) Final test 100%

Jolanta Hachlarski
approved by manufacturer

11.09.2014
date

i. A. W. B.
approved by SMA

12.09.14
date

PS/dtw/2230 04-06756
© 2014 dtw sp. z o.o. All Rights Reserved

	Product Specification		64-113200.01	
	Power Transformer Block		PS/dtw/2230	
	26V / 230V 50Hz - 1650VA (3200VA)		issue: 01	2014-09-04
	with 120µH smoothing choke and integrated current transformer		page: 5	pages: 9

Design, material specification and properties:
In the selection of the materials and the way of application, have been taken in consideration the requirements of the standards: EN61558-1, EN61558-2-4 and Product Specification PS/dtw/2230.

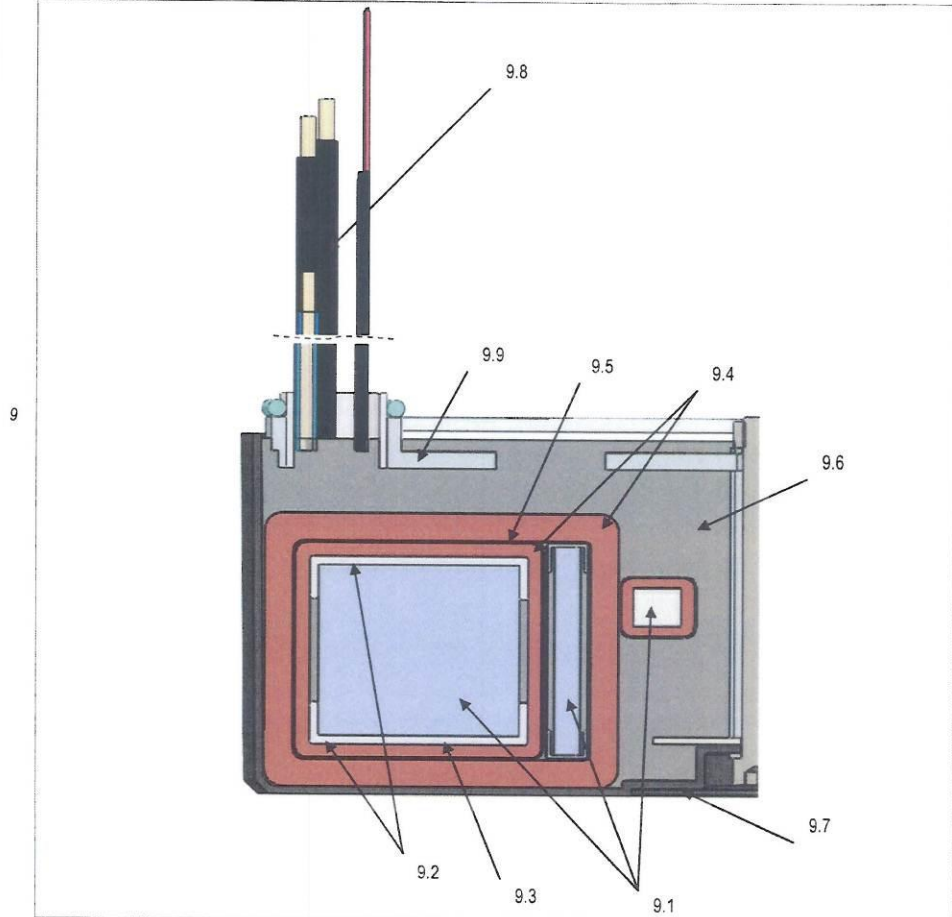

	Name	Description	Note
9.1	Magnetic Core	<i>Material:</i> Transformer and CT: high permeability grain oriented electrical steels stand. IEC 404 , EN 10107 Chokes: 6.5% silicon steel	
9.2	Plastic caps <i>(Bobbin or Core tube)</i> (For mechanical support and Layer insulation)	<i>Material:</i> Flame retardant UL 94-V0,V1,V2,HB Polyamide (PA 6, PA66) E.g.: DuPont Zytel FR7200V0F, FR7026V0F, 70G30HSL BASF - Ultramid C3U	
9.3	Supplementary Layer <i>(Layer Insulation)</i>	Layer insulation film. <i>Material:</i> Any Recognized Component Plastic (QMFZ2), Polyethylene Terephthalate Film (PET) 0,075mm – various manufactureres or aramid insulating paper – NOMEX 410	

J. K. H. H. H. 11.09.2014 *i. A. B.* 12.09.14
 approved by manufacturer date approved by SMA date PS/dtw/2230_04-06756
 © 2014 dtw sp. z o.o. All Rights Reserved

		Product Specification	
		PowerTransformer Block 26V / 230V 50Hz - 1650VA (3200VA) with 120µH smoothing choke and integrated current transformer	
		64-113200.01	
		PS/dtw/2230	
		issue: 01	2014-09-04
		page: 6	pages: 9
9.4	PRI Winding SEC Winding CT Winding <i>(Magnet Wire)</i>	Material: Polyester basecoat with polyamide-imide topcoat, ANSI MW 35 type, various manufacturers, Grade – 2 E.g.:Dahrendrad AB – Damid PE UL File E101843	
9.5	Insulation between PRI and SEC <i>(Interwinding Insulation)</i>	Reinforced insulation - Creepage distances "cr" and clearances "cl" between live parts of PRI circuit and live parts of SEC circuit: cr ≥ 9,5 mm , cl ≥ 5,5 mm. - Distances trough insulation between PRI and SEC min. 0,3 mm ; The insulation between the primary and the secondary consists of min. four layers of 0,075mm thick Polyethylene Terephthalate Film (PET) – DuPont.	
9.6	Resin <i>(Potting Compound)</i>	Polyurethane or Epoxy Potting System Flammability: UL94 – V0 PU515 / PH27 ElantasCamattiniSpA <i>(old name PL515 / G27 CamattiniSpA)</i>	
9.7	Plastic Case <i>(Potting Shell)</i>	Polyamide PA6, PA66 UL 94-V0, V1, V2, or HB DuPont – Zytel 70G30HSL	
9.8	<i>(Lead Wire, Sleaving)</i>	double insulation: Insulated stranded copper cable with fiberglass sleeve coated with polyurethane or silicone varnish. Material: UL Recognized XLPE ; XLPO ; SI ; ETFE; TFE Stranded Cable E.g.:Varpren UL155 – Omerin Fiberglass sleeve coated with polyurethane or silicone varnish. E.g.:ADAGLAS – Damenius GmbH ; D19.61 – F.I.E Balconi ; Siligaine 15C4– Omerin S.A.S.	
9.9	<i>Aluminium plate</i>	5mm thickness	

Jakob Hochbuck
approved by manufacturer

11.09.2014
date

i. A. B. B.
approved by SMA

12.09.14
date

PS/dtw/2230 04-06755

© 2014 dtw sp. z o.o. All Rights Reserved

	Product Specification		64-113200.01	
	PowerTransformer Block		PS/dtw/2230	
	26V / 230V 50Hz - 1650VA (3200VA)		issue: 01	2014-09-04
	with 120µH smoothing choke and integrated current transformer		page: 7	pages: 9

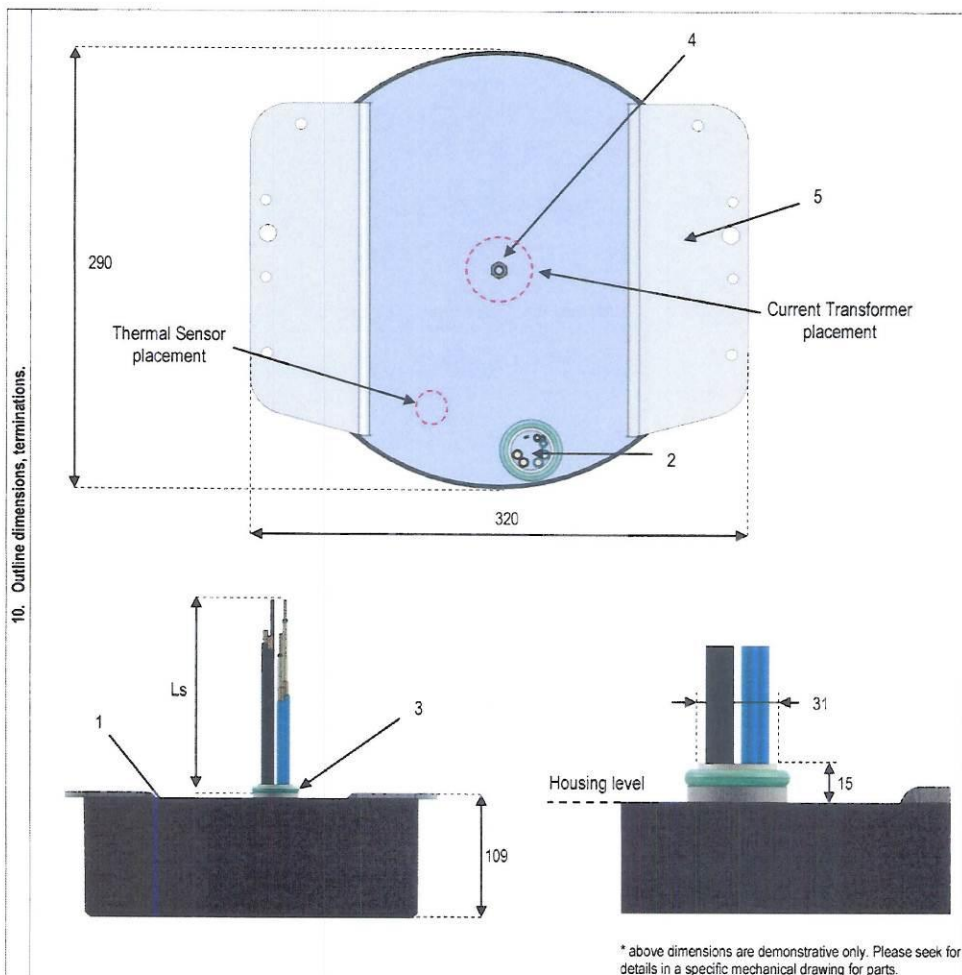

Item_ref	Title/Name, designation	Material, dimension, etc.
1	Plastic Case (Potting Shell) dtw_PP2362	Polyamide PA6, PA66 UL 94-V0,V1,V2, or HB DuPont – Zytel 70G30HSL
2	Terminations – PRI, SEC, TS, CT	Insulated stranded cable XLPE, XLPO or SI
3	O-ring	Silicone VMQ, Dim.: 30x6.0, hardness: 50 ±5 ShA, green
4	M8 Screw	HEX M8x100mm; Stainless Steel A2
5	Aluminum Plate dtw_MP2360	Mounting holes and wire channel position: 100% tested

Notes:
All wires budled with additional sleeve for shipping and assembling purposes. Resin level 1-3mm below housing level.

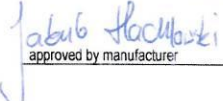
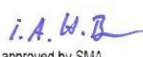
 approved by manufacturer
 11.09.2014 date
 
 approved by SMA
 12.09.14 date
 PS/dtw/2230_04-06756
 © 2014 dtw sp. z o.o. All Rights Reserved

	Product Specification		64-113200.01	
	Power Transformer Block		PS/dtw/2230	
	26V / 230V 50Hz - 1650VA (3200VA)		issue: 01	2014-09-04
	with 120µH smoothing choke and integrated current transformer		page: 8	pages: 9

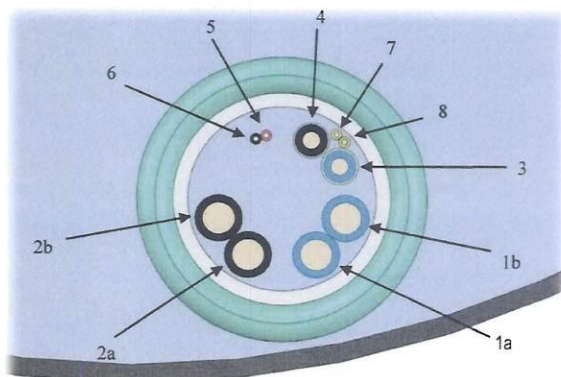

Terminations – PRI					
No	Type, material, etc.	Ls [mm]	Colour / mark	ends	Note
1a	Insulated XLPE, XLPO, SI stranded wire 2x 16 mm ²	105 ^{+10/-0}	BU	Crimped to squared shape	Marking by the label
1b	Insulated XLPE, XLPO, SI stranded wire 2x 16 mm ²	115 ^{+10/-0}	BU	Crimped to squared shape	Marking by the label
2a	Insulated XLPE, XLPO, SI stranded wire 2x 16 mm ²	133 ^{+10/-0}	BK	Crimped to squared shape	Marking by the label
2b	Insulated XLPE, XLPO, SI stranded wire 2x 16 mm ²	143 ^{+10/-0}	BK	Crimped to squared shape	Marking by the label
Terminations - SEC					
No	Type, material, etc.	Ls [mm]	Colour / mark	ends	Note
3	Insulated XLPE, XLPO, SI stranded wire 6 mm ²	180 ^{+10/-0}	BU	cable end sleeve 6 mm ² / 18 mm	SEC ¹⁾
4	Insulated XLPE, XLPO, SI stranded wire 6 mm ²	150 ^{+10/-0}	BK	cable end sleeve 6 mm ² / 18 mm	SEC ¹⁾
1) SEC wires have an additional sleeve as second insulation of length 30mm (+0/-20) shorter than wire.					
Terminations – Current Transformer CT					
No	Type, material, etc.	Ls [mm]	Colour / mark	Cable ends	Note
5	Insulated XLPE, XLPO, SI stranded wire 0,35 mm ²	180 ^{+10/-0}	RD	Pancon	
6	Insulated XLPE, XLPO, SI stranded wire 0,35 mm ²	180 ^{+10/-0}	BK	CE100F22-02	
Terminations – sensor TS					
No	Type, material, etc.	Ls [mm]	Colour / mark	Cable ends	Note
7	Insulated XLPE, XLPO, SI stranded wire 0,35 mm ²	120 ^{+10/-0}	YE	Pancon	
8	Insulated XLPE, XLPO, SI stranded wire 0,35 mm ²	120 ^{+10/-0}	YE	CE100F22-02	
Notes: All cables lengths Ls: 100% tested					

Jakub Hochlaski
approved by manufacturer

11.09.2014
date

i.A. W.B.
approved by SMA

12.09.14
date

PS/dtw/2230_04-06756
© 2014 dtw sp. z o.o. All Rights Reserved

	Product Specification		64-113200.01
	PowerTransformer Block		PS/dtw/2230
	26V / 230V 50Hz - 1650VA (3200VA) with 120µH smoothing choke and integrated current transformer		issue: 01 2014-09-04 page: 9 pages: 9

11		Marking	
11.1	Product main label with data matrix code	 1650PTB2230  64-113200.01 26V/230V/1650VA  64113200.01#501397#1.0#3614	
11.2	Positioning of marking: - Product main label - Quality check label		

12		Notes	
12.1	The transformer's Output Power and Ambient Temperatures may be increased over Rated values on the following conditions: the value and the duration of the transformer's Output Power will be adjusted to the intensity of the forced cooling in such manner that the temperature of the transformer's windings will not surpass 120°C at any time.		

issue	PS History	Date
01	Initial Release	2014-05-13
02	Updates: no-load output voltage (p:5.9) ; dimensions on drawings (p:10); primary terminations and TS terminations (p:10.2) ; new label (p:11.1)	2014-08-13

Jakub Hochmiski
approved by manufacturer

11.09.2014
date

i.A. G. B...
approved by SMA

12.09.14
date

PS/dtw/2230_04-06756

© 2014 dtw sp. z o.o. All Rights Reserved

Annex No. 5

Pictures of the unit

Inverter Sunny Island 4.4 Enclosure front



Enclosure bottom (connectors)



Enclosure top side



Enclosure left side



Enclosure right side



Enclosure back



Enclosure open

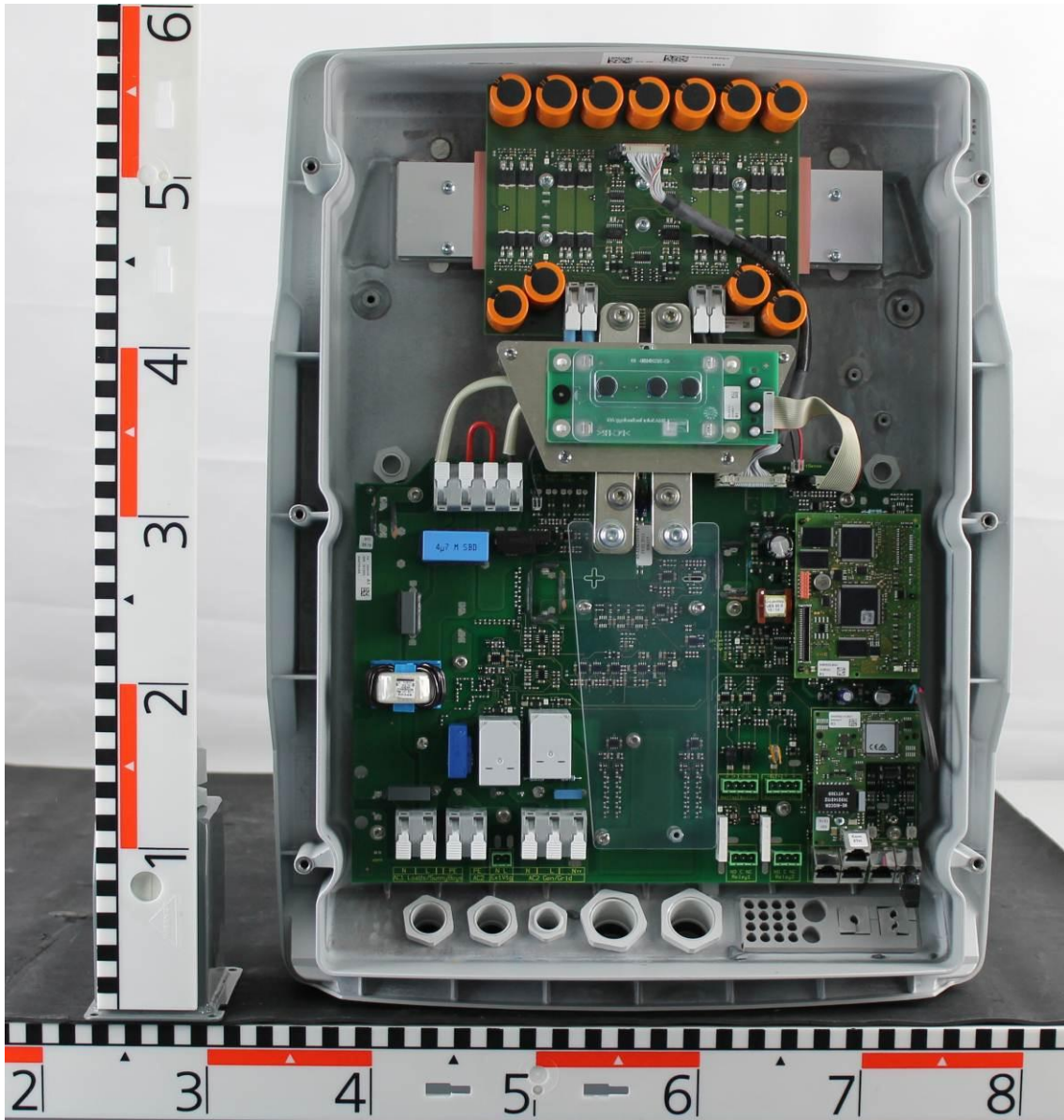

SIWRS board front side

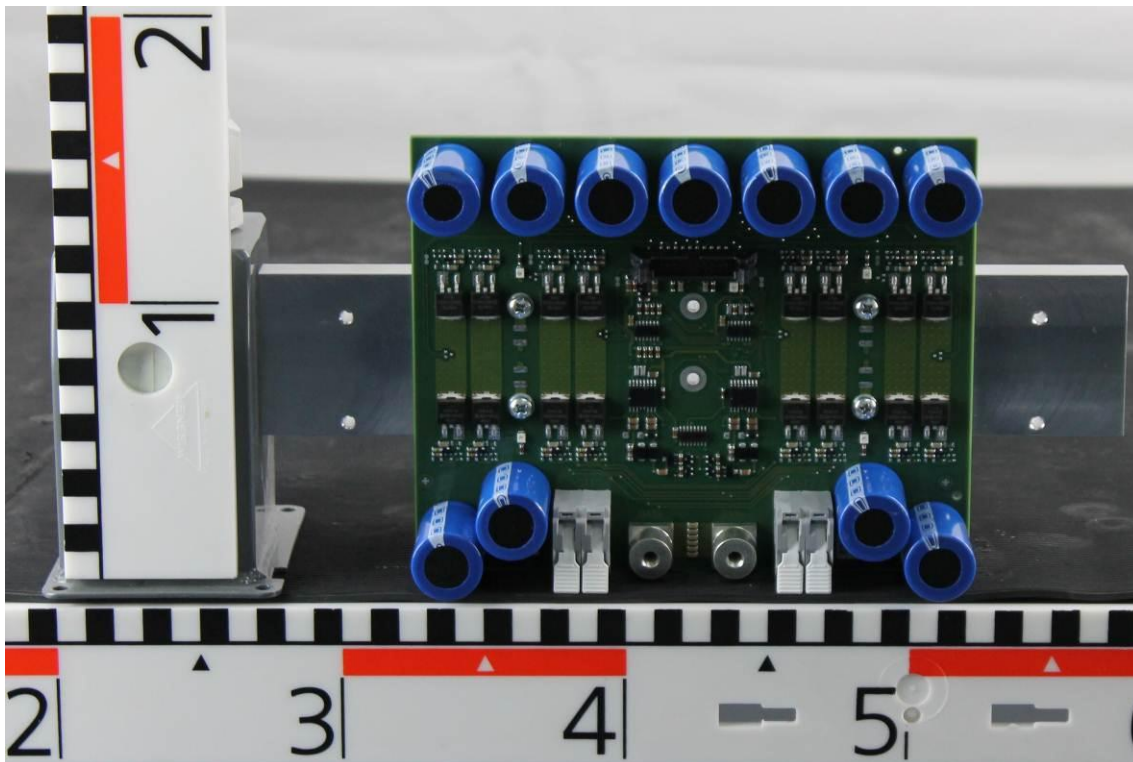

SIWRS board front side

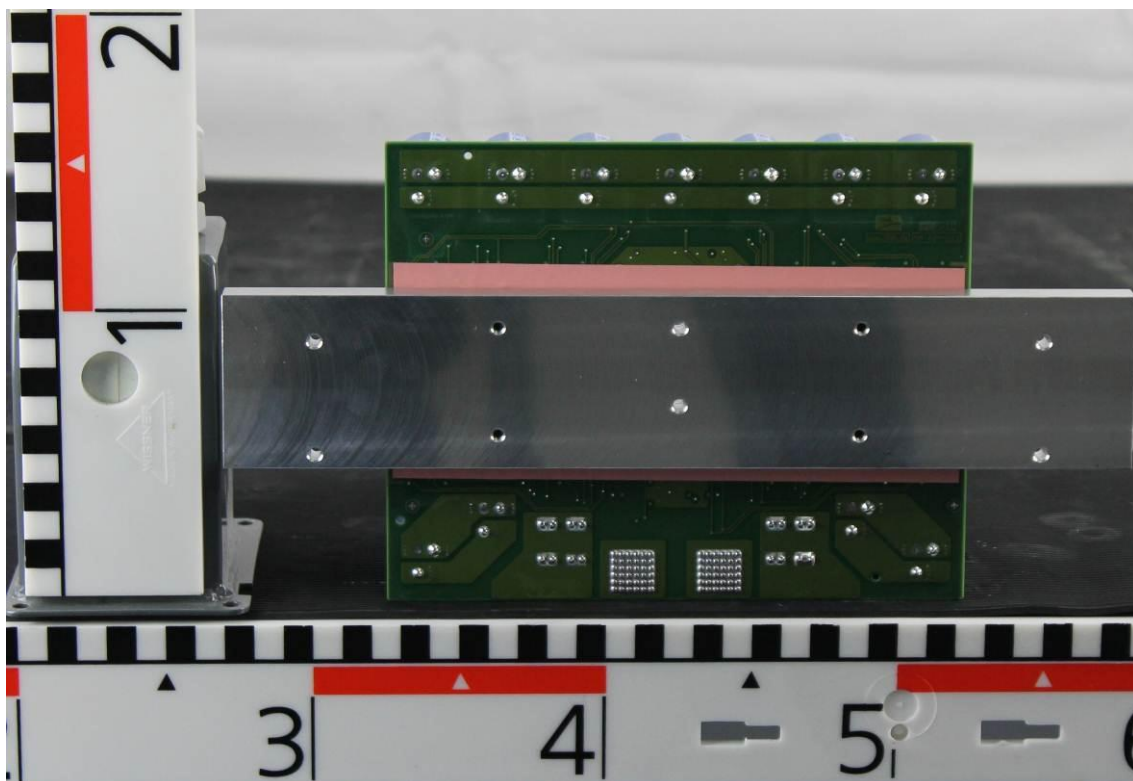

SIAST 50-48 board front side

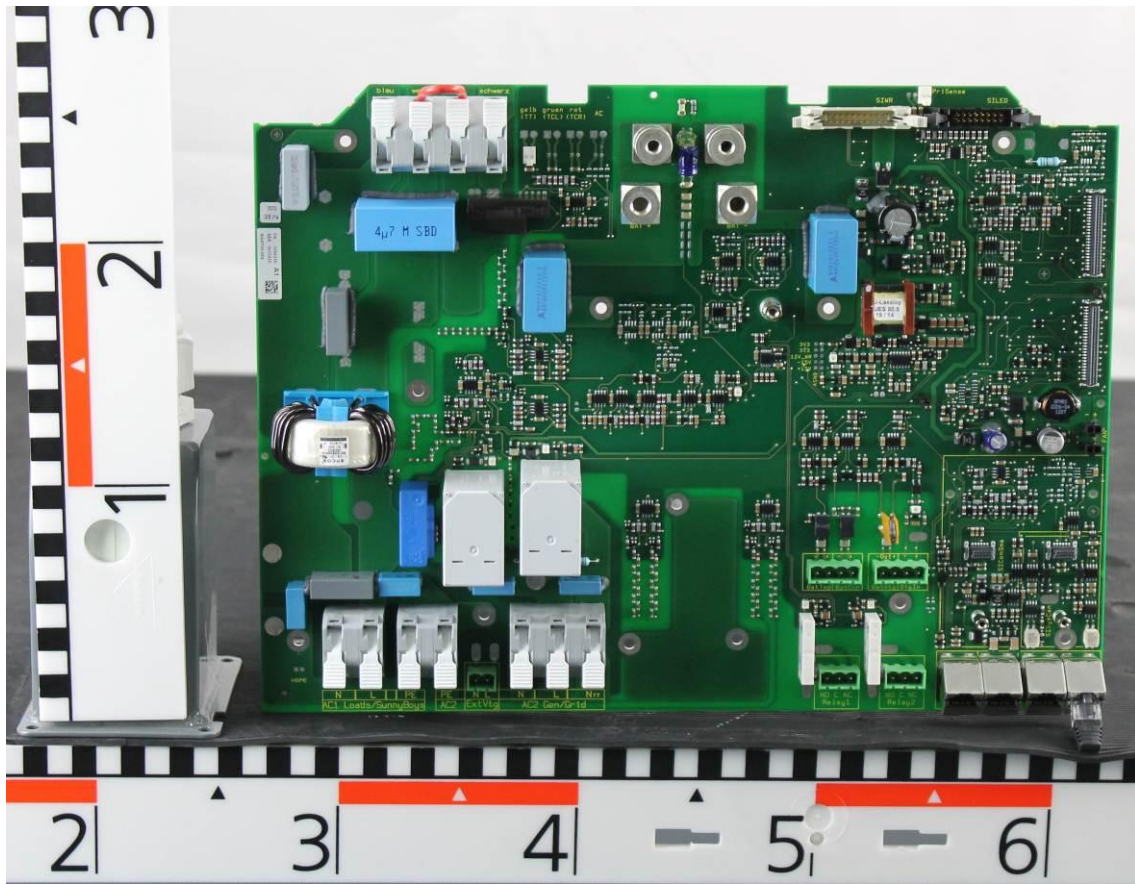

SIAST 50-48 board back side

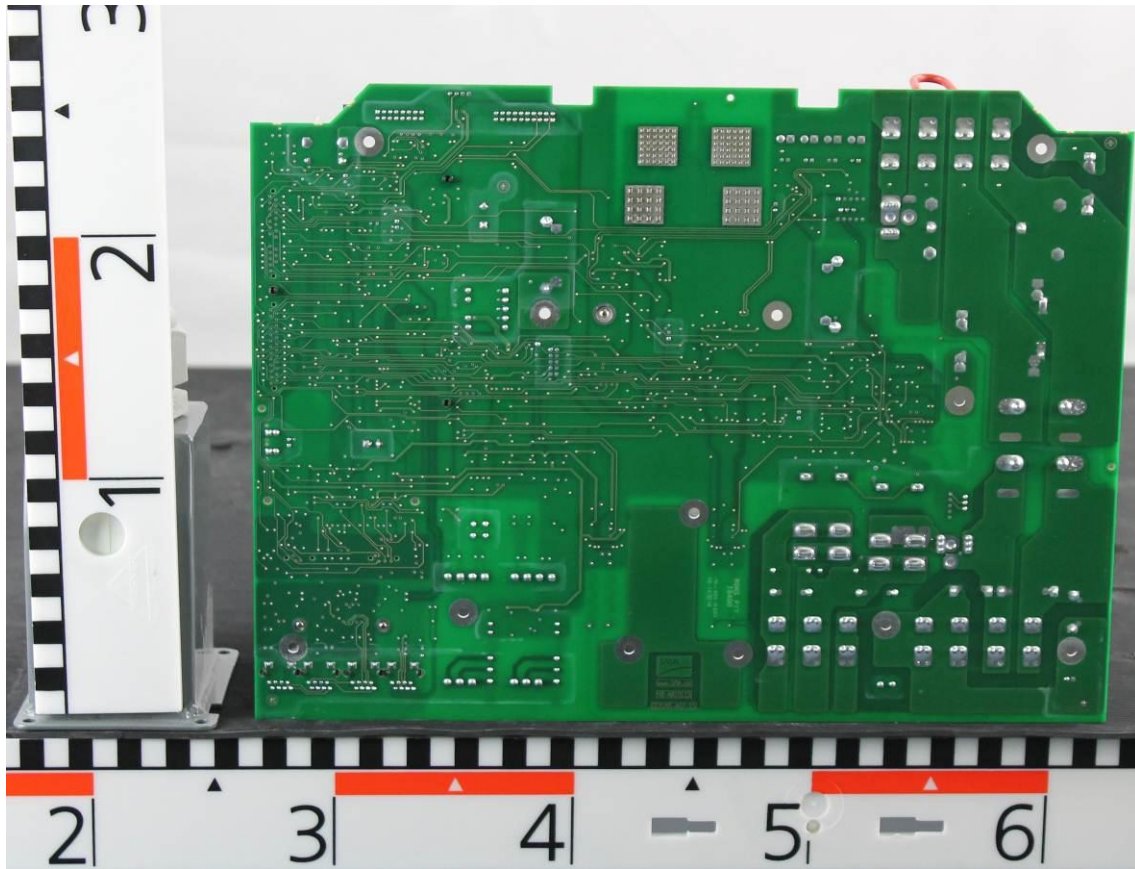

Earth connection

Following pictures describe the PE path within the unit beginning from the main protective earthing terminal where the external PE conductor is connected in the final installation. The earth is distributed via traces on the PCB and via screw connection to the metal enclosure. All parts of the unit which are required to be earthed are reliably bonded to protective earth. See pictures below.

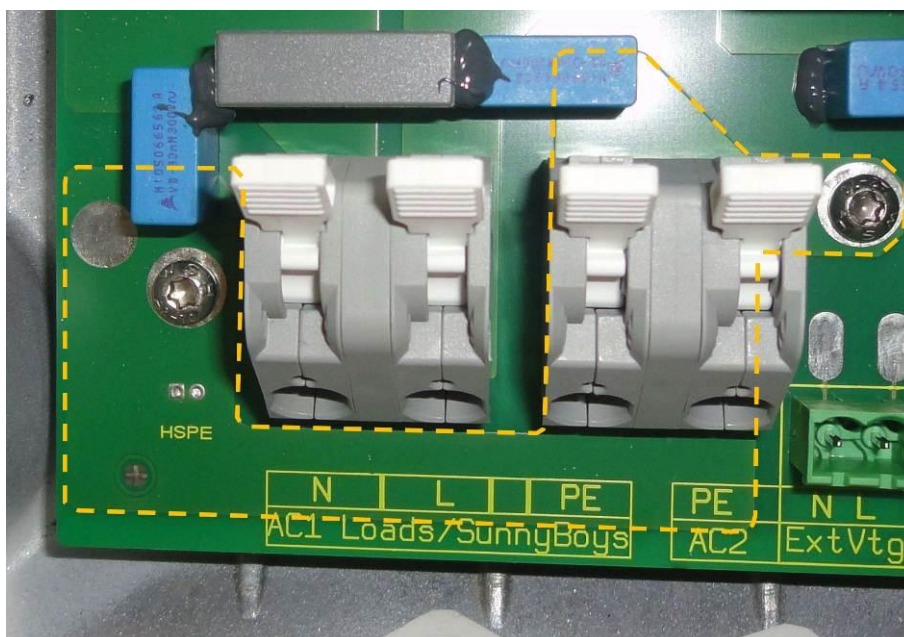

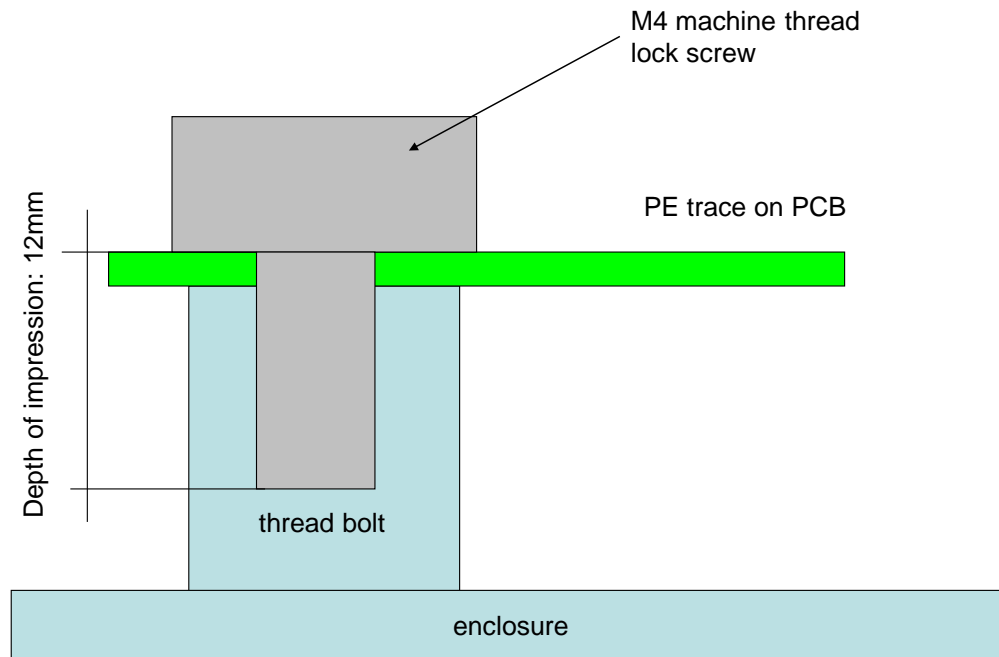

Fan wire run

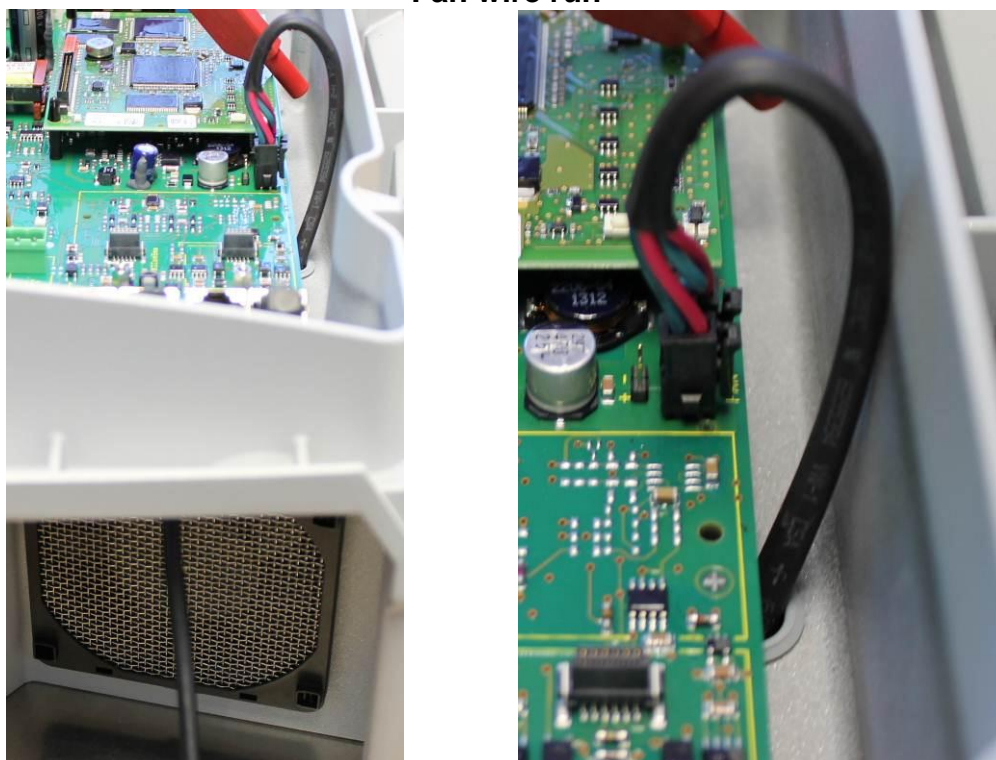

Annex No. 6

Test Equipment List

Equipment	Internal No.	Manufacturer	Type	Serial No.	Last Calibration
Multimeter	35	HP	971A	JP40010732	Jan. 13
spring hammer	63	PTL	F 22.50	5001449	Mai. 12
Test Finger	71	LGA	-	-	Jul. 11
glow wire testapparatus	75	LGA	-	-	-
Electronic Source	120	ET Euro-Test	LAB/SM315	01.39.3155	Aug. 09
DMM	135	Voltcraft	M-3860M	BG754923	Jan. 13
IEC-articulation finger with removable stop plate	211	PTL	P10.14S (Prüfsonde B)	5031168	Jul. 11
DC Power Supply	362	PCE	A12KW	E00126287	
DC Power Supply	363	PCE	A12KW	E00126314	
DC Power Supply	364	PCE	A12KW	E00126318	
Thermometer	488	Greisinger	GMH 3230	-	Aug. 13
Ball Pressure Tester	510	A.Pfeifer	-	-	Jul. 11
Current clamp	623	Voltcraft	VC607	718548	Aug. 13
Digital Multimeter	663	Gossen-Metrawatt	METRAHit 29S	SF4220	Jan. 13
Dielectric tester	730	SPS electronic	HA 2201G	4032304	Jul. 13
Needle Flame Tester/gas cyl.	748	ED&D Inc.	BTA-01	-	Nov. 08
Leakage current meter	812	Kikusui	TOS3200	NK003303	Mai. 13
Hygro- /Thermo- /Barometer	1073	Greisinger	GFTB 100	90258040	Feb. 13