

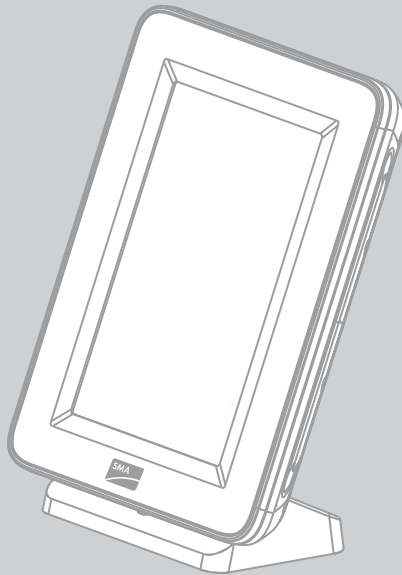

User Manual
SUNNY VIEW



Legal Provisions

The information contained in this document is the property of SMA Solar Technology AG. Publishing its content, either partially or in full, requires the written permission of SMA Solar Technology AG. Any internal company copying of the document for the purposes of evaluating the product or its correct implementation is allowed and does not require permission.

Declaration of Conformity

SMA Solar Technology AG hereby declares that this equipment is in compliance with the essential requirements and other relevant provisions of Directive 1999/5/EC. The entire CE Declaration of Conformity can be downloaded at www.SMA-Solar.com.

SMA Warranty

You can download the current warranty conditions from the Internet at www.SMA-Solar.com.

Online services, libraries, open source licences

When using this equipment you will also be using online services from other providers. These are listed in the section "Online services". The use of these services is governed by the current terms of use of each of the providers listed in the section "Online services". By using the online services you also declare your agreement with the regulations listed. The use of libraries and software provided by 3rd parties is governed in the same way as that of online services.

Online services

This software is provided "as is" and any express or implied warranties and liability to correct errors are disclaimed. In no event shall Supplier be liable for any direct, indirect, incidental or consequential damages or infringement of any Intellectual Property Rights arising in any way out this software. Customer assumes all risk for the selection of this software, including risks to achieve Customer's intended results and for the installation, use and results obtained from it. Furthermore, this software uses/may use 3rd party services. The 3rd party service is governed under separate terms & conditions which are available at

- OpenWeatherMap: <http://openweathermap.org>

Customer accepts that these terms and conditions shall be applied to this software. Same applies for the use of the chosen Newsfeed service.

Libraries

The Sunny View software uses the AChartEngine library licensed under ASL 2.0, the microlog4android library licensed under Apache 2.0 and MIT, and the twitter4j-core-android library licensed under JSON.

Open source licences

Sunny View is based on the Android 2.6.35.3 kernel and the U-Boot 2009.08 version, which are licensed under the GPLv2 Open Source Licence. A copy of the GPLv2 licence is provided on the included CD. You can request the source code with modifications from the SMA Service Line. Copyright notices are integrated into the source code.

In addition, the Sunny View uses the Apache Licence 2.0 with Android 2.2 (API level 8, revision 2). A copy of the Apache Licence 2.0 is provided on the included CD.

Trademarks

All trademarks are recognized even if these are not marked separately. Missing designations do not mean that a product or brand is not a registered trademark.

The Bluetooth® word mark and logos are registered trademarks owned by Bluetooth SIG, Inc. and any use of such marks by SMA Solar Technology AG is under license.

QR Code® is a registered trademark of DENSO WAVE INCORPORATED.

SMA Solar Technology AG

Sonnenallee 1
34266 Niestetal
Germany
Tel. +49 561 9522-0
Fax +49 561 9522-100
www.SMA.de
E-mail: info@SMA.de

© 2004 to 2014 SMA Solar Technology AG. All rights reserved

Information for USA and Canada only

Legal Provisions

Copyright © 2014 SMA America, LLC. All rights reserved.

No part of this document may be reproduced, stored in a retrieval system, or transmitted, in any form or by any means, be it electronic, mechanical, photographic, magnetic or otherwise, without the prior written permission of SMA America, LLC.

Neither SMA America, LLC nor SMA Solar Technology Canada Inc. makes representations, express or implied, with respect to this documentation or any of the equipment and/or software it may describe, including (with no limitation) any implied warranties of utility, merchantability, or fitness for any particular purpose. All such warranties are expressly disclaimed. Neither SMA America, LLC nor its distributors or dealers nor SMA Solar Technology Canada Inc. nor its distributors or dealers shall be liable for any indirect, incidental, or consequential damages under any circumstances.

(The exclusion of implied warranties may not apply in all cases under some statutes, and thus the above exclusion may not apply.)

Specifications are subject to change without notice. Every attempt has been made to make this document complete, accurate and up-to-date. Readers are cautioned, however, that SMA America, LLC and SMA Solar Technology Canada Inc. reserve the right to make changes without notice and shall not be responsible for any damages, including indirect, incidental or consequential damages, caused by reliance on the material presented, including, but not limited to, omissions, typographical errors, arithmetical errors or listing errors in the content material.

All trademarks are recognized even if these are not marked separately. Missing designations do not mean that a product or brand is not a registered trademark.

The *Bluetooth*[®] word mark and logos are registered trademarks owned by Bluetooth SIG, Inc. and any use of such marks by SMA America, LLC and SMA Solar Technology Canada Inc. is under license.

SMA America, LLC

3801 N. Havana Street
Denver, CO 80239 U.S.A.

SMA Solar Technology Canada Inc.

2425 Matheson Blvd. E
7th Floor
Mississauga, ON L4W 5K4
Canada

Important Safety Instructions

SAVE THESE INSTRUCTIONS

This manual contains important instructions for the following products:



- SUNNY VIEW

This manual must be followed during installation and maintenance.

The product is designed and tested in accordance with international safety requirements, but as with all electrical and electronic equipment, certain precautions must be observed when installing and/or operating the product. To reduce the risk of personal injury and to ensure the safe installation and operation of the product, you must carefully read and follow all instructions, cautions and warnings in this manual.

Warnings in this Document

A warning describes a hazard to equipment or personnel. It calls attention to a procedure or practice, which, if not correctly performed or adhered to, could result in damage to or destruction of part or all of the SMA equipment and/or other equipment connected to the SMA equipment or personal injury.

Symbol	Description
 DANGER	DANGER indicates a hazardous situation which, if not avoided, will result in death or serious injury.
 WARNING	WARNING indicates a hazardous situation which, if not avoided, could result in death or serious injury.
 CAUTION	CAUTION indicates a hazardous situation which, if not avoided, could result in minor or moderate injury.
NOTICE	NOTICE is used to address practices not related to personal injury.

General Warnings

WARNING

All electrical installations must be made in accordance with the local and *National Electrical Code*® ANSI/NFPA 70 or the *Canadian Electrical Code*® CSA C22.1. This document does not and is not intended to replace any local, state, provincial, federal or national laws, regulations or codes applicable to the installation and use of the product, including without limitation applicable electrical safety codes. All installations must conform with the laws, regulations, codes and standards applicable in the jurisdiction of installation. SMA assumes no responsibility for the compliance or non-compliance with such laws or codes in connection with the installation of the product.

The product contains no user-serviceable parts.

For all repair and maintenance, always return the unit to an authorized SMA Service Center.

Before installing or using the product, read all of the instructions, cautions, and warnings in this manual.

Table of contents

1	Information on this Document	9
2	Security	11
2.1	Intended Use	11
2.2	Safety Precautions	11
2.3	Supported Products	12
3	Product Description	13
3.1	Sunny View	13
3.2	Type Label	15
4	Operation	16
4.1	Menu Structure	16
4.2	Operating the Sunny View	18
5	Home Menu Item	19
5.1	Layout of the Home Slides	19
5.2	Header Layout	20
5.3	PV Plant Data	20
5.3.1	Slides without SMA CT Meter	21
5.3.2	Slide with SMA CT Meter	22
5.4	Online Data	23
6	Charts Menu Item	24
7	Events Menu Item	26
8	Settings Menu Item	28
8.1	Adjusting the Brightness of the Display	28
8.2	Disabling the Display	28
8.3	Setting the Scaling of the Daily Graph	28
8.4	Setting the Error Alert	29
8.5	Setting the Key Clicks	29
8.6	Identifying the Sunny View	29
8.7	Setting the Language	29

- 8.8 Setting the Country Settings 30
- 8.9 Setting the Date and Time 30
- 8.10 Searching for a New PV Plant 31
- 8.11 Adding a New Device 31
- 8.12 Replacing a Device 32
- 8.13 Changing the Device Name 33
- 8.14 What to Do in Case of a Lost PV Plant Password 33
- 8.15 Changing the PV Plant Password 33
- 8.16 Displaying Connected Devices 34
- 8.17 Setting up a WLAN Connection 34
- 8.18 Checking and Setting Up a *Bluetooth* Connection 35
- 8.19 Configuring Online Data 35
- 8.20 Changing the Duration of the Slide Show 35
- 8.21 Selecting Photovoltaics Visualization 36
- 8.22 Activating Demo Mode 36
- 9 Maintenance and Care 37**
 - 9.1 Safely Removing the Micro SDHC Card 37
 - 9.2 Performing an Update 37
 - 9.3 Restoring Factory Settings 38
 - 9.4 Generating a Back-Up File 39
 - 9.5 Restoring Sunny View Data from a Back-up File 39
- 10 Decommissioning 40**
 - 10.1 Decommissioning the Sunny View 40
 - 10.2 Disposing of the Sunny View 40
- 11 Troubleshooting 41**
- 12 Technical Data 46**
- 13 Compliance Information 48**
- 14 Contact 49**

1 Information on this Document









Validity

This document is valid for device type "VIEW-10.GR1" (Sunny View).

Target Group

This document is intended for end users.

Symbols

Symbol	Explanation
	Indicates a hazardous situation which, if not avoided, will result in death or serious injury
	Indicates a hazardous situation which, if not avoided, can result in death or serious injury
	Indicates a hazardous situation which, if not avoided, can result in minor or moderate injury
	Indicates a situation which, if not avoided, can result in property damage
	Information that is important for a specific topic or goal, but is not safety-relevant
	Indicates a requirement for meeting a specific goal
	Desired result
	A problem that could occur

Typographies

Typography	Explanation	Example
bold	<ul style="list-style-type: none"> • Display texts • Elements on a user interface • Terminals • Elements to be selected • Elements to be entered 	<ul style="list-style-type: none"> • The value can be found in the field Energy. • Select Settings. • Enter the value 10 in the field Minutes.
>	<ul style="list-style-type: none"> • Connects several elements to be selected 	<ul style="list-style-type: none"> • Select Settings > Date.
[Button/Key]	<ul style="list-style-type: none"> • Button or key to be selected or pressed 	<ul style="list-style-type: none"> • Select [Next].

Nomenclature

Complete designation	Designation in this document
PV plant comprising a PV array, monitoring devices and inverters	PV plant
SMA Bluetooth® Wireless Technology	Bluetooth
SMA Solar Technology AG	SMA
SMA America, LLC	
SMA Solar Technology Canada Inc.	

2 Security

2.1 Intended Use

The Sunny View is a communication device that receives, displays and stores data from SMA inverters.

The Sunny View is only suitable for indoor use.

For safety reasons, it is not permitted to modify the product or install components that are not explicitly recommended or distributed by SMA for the product. Unauthorized modifications and installations are not permitted and will void all warranty claims. Any use of the product other than described in the Intended Use section does not qualify as appropriate.

The type label must remain permanently attached to the product.

The data collected by Sunny View on the amount of power generated by your PV plant may deviate from the energy meter data. The Sunny View data must not be used for billing purposes.

Use the Sunny View only in accordance with the enclosed documentation and with the local standards and directives. Any other application may cause personal injury or property damage.

- The Sunny View is only to be operated using the supplied plug-in power supply and in the intended voltage range (see Section 12 "Technical Data", page 46).

The enclosed documentation and the documentation on the CD-ROM are an integral part of this product. Keep the documentation in a convenient place for future reference and observe all instructions contained therein.

Radio Frequency Exposure

This product should be installed and operated with a minimum clearance of 20 cm (8 in.) from your body.

2.2 Safety Precautions

NOTICE

Magnetic components in the Sunny View can damage sensitive objects

The Sunny View contains magnetic components, e.g. loudspeakers.

- You should not place any objects which are sensitive to magnets (e.g. EC cards) on the Sunny View.



Preventing unauthorized access

PV plants are delivered with "0000" as default password. This means that unauthorized users can gain access to the data of the PV plant.

- Change the default plant password (see Section 8.15).

2.3 Supported Products

SMA Inverters

- All SMA inverters with integrated *Bluetooth*
- SMA inverters with retrofitted *SMA Bluetooth Piggy-Back/SMA Bluetooth Piggy-Back Plus* from firmware version 02.00.00.R. A list of the supported inverters can be found in the *SMA Bluetooth Piggy-Back/SMA Bluetooth Piggy-Back Plus* manual.
- Sunny Backup with retrofitted *SMA Bluetooth Piggy-Back Off-Grid* from firmware version 01.00.00.R. A list of the supported Sunny Backups can be found in the *SMA Bluetooth Piggy-Back Off-Grid* manual.

Additional SMA Products

- SMA CT Meter from firmware version 1.0*

* for Japan only

3 Product Description

3.1 Sunny View

The Sunny View is a communication device that receives, displays and stores data from SMA inverters. The Sunny View displays the PV plant data in the form of slides on the display.

The Sunny View can be connected to the Internet via a WLAN. If there is a connection to the Internet, the Sunny View can display newsfeeds and meteorological data.

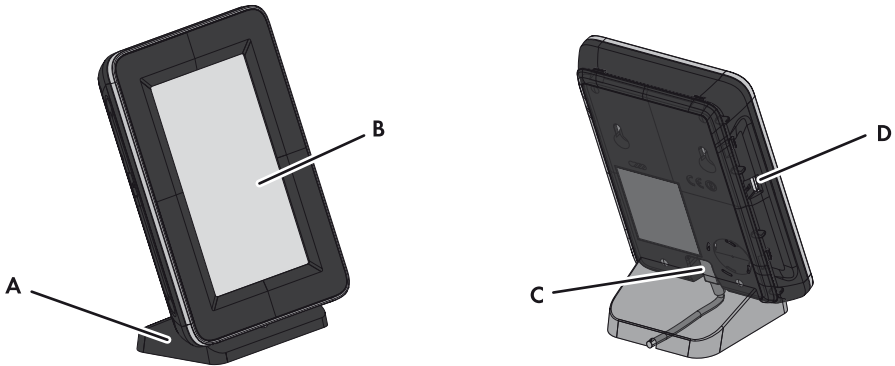

Figure 1: Design of the Sunny View

Item	Designation
A	Tabletop stand
B	Display
C	Grid connection
D	Slot for micro SDHC card

The display is used to control the device and display information.

The Sunny View communicates via *Bluetooth* with inverters and the SMA CT Meter (for Japan only).

The Sunny View saves the PV plant data in its internal memory. If a micro SDHC card is available, you can transfer the PV plant data to it.

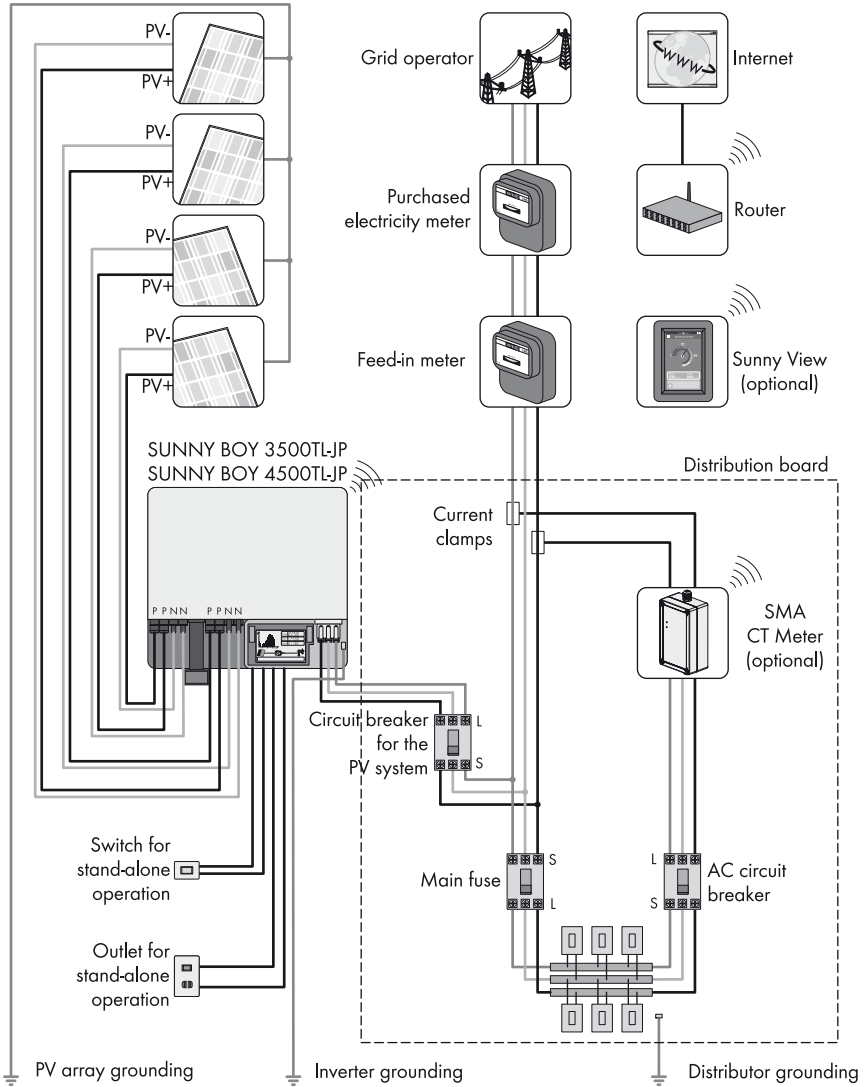

Figure 2: Illustration of a PV plant with Sunny View (example)





3.2 Type Label

The type label clearly identifies the product. The type label is located on the back of the product. If the product is positioned on the tabletop stand, you must remove it from the tabletop stand to see the type label. You can read the following data from the type label:

- Device type (Type)
- Serial number (Serial Number)
- MAC address (MAC Address)
- Device-specific characteristics

You will require the information on the type label to use the product safely and when seeking customer support from the SMA Service Line.

Symbols on the Type Label

Symbol	Designation	Explanation
	MIC designation	Type certification in accordance with the Japanese Radio Law
	C-Tick	The product complies with the requirements of the applicable Australian EMC standards.
	Bluetooth® Wireless Technology	The product has a <i>Bluetooth</i> interface.
	Data matrix code	2D code for device-specific characteristics

4 Operation

4.1 Menu Structure

The menu consists of several menu items. Using the menu items, you can control the slides displayed and configure the Sunny View settings.

You can call up the menu using  (for the position of the icon, see Section 5.2).

Home			
Charts			
Events			
Settings	General	Display	Brightness
			Display activity
			Scaling of day charts
		Sounds	Error alert
			Key clicks
		Information	Serial number
			Firmware version
			Hardware
			Bluetooth version
			WLAN Mac ID
		Date & time	Automatic
			24-hour format
			Time zone
			Date
	Time		
	International	Language	
		Country	
	Slide show	Slide duration	
		PV visualization	
Online data		Newsfeed	
	Weather		

Settings	Wireless	Bluetooth	Connection quality
			NetID
			Refresh after
		Wi-Fi	Refresh after
			Other networks
	PV plant	New search	Plant search
			Device search
		Information	
		PV plant password	
	Service	Update	
		factory settings	
Back-up file		Generate back-up file	
		Restore back-up file	











4.2 Operating the Sunny View

Touch the display with your finger or the supplied touch-screen stylus pen to navigate the Sunny View and to enter information.

NOTICE

Sharp or pointed objects can damage the display.

- Use your finger or the touch-screen stylus pen to control the Sunny View.

Symbol	Name	Description
	Button	To activate a button, simply tap it once.
	Menu	Tap this button to access the menu.
	Back	Tap this button to go back to the previous menu.
	Text box	To enter numbers or text, tap the text box. A keyboard will appear on the display.
	Drop-down list	Simply tap drop-down lists once to open.
	List	Lists are marked by a bar on the right-hand side of the display. You can scroll through lists by sliding your finger up or down to any position on the display.
	Option	To enable an option, simply tap it. Enabled options are colored. Only one option may be enabled at any time.
	Checkbox	You can enable or disable a checkbox by tapping it. Enabled checkboxes are colored.
	Slider	You can move the slider by dragging your finger to the left or right.
	Info icon	Press this icon to display additional information.

5 Home Menu Item

5.1 Layout of the Home Slides

The slides in the **Home** menu item display the status of the PV plant and the PV plant data. If there is a connection to the Internet, the **Home** slides display online data from the Internet. The slides in the slide-show change automatically after a preset display time (see Section 8.20). You can scroll through the **Home** slides manually by dragging your finger to the left or right.

Procedure:

- To view the **Home** slides, select  > **Home**.

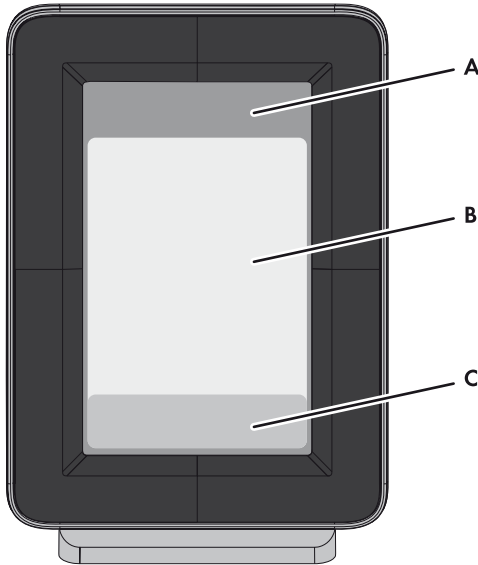

Figure 3: Layout of the **Home** slides

Item	Designation
A	Header
B	PV plant data
C	Online data

5.2 Header Layout

The header of the **Home** slides is located in the top section of the display.

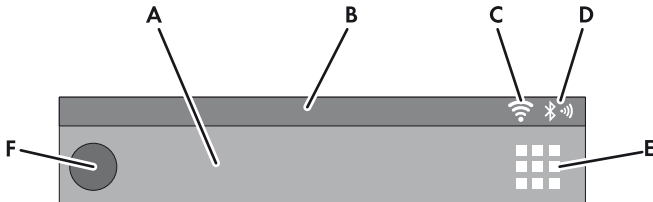

Figure 4: Layout of the header

Item	Designation	Description
A	Name	Name of the slide
B	Date and time	Current date and time
C	WLAN	Quality of the WLAN connection
D	Bluetooth signal strength	Quality of the Bluetooth connection
E	Menu	Tap this button to access the menu.
F	Event symbol	If there is an unread event, the symbol for the relevant event is displayed (see Section 7 "Events Menu Item", page 26). If there are several unread events, the symbol for the most serious event is displayed. Tip: tap the symbol to access the list of events.

5.3 PV Plant Data

The PV plant data is divided into multiple slides. You can scroll through the slides by dragging your finger to the left or right. The slides change automatically after a preset time. You can change the preset time (see Section 8.20 "Changing the Duration of the Slide Show", page 35).

You can enable or disable the slides in the settings (see Section 8.21 "Selecting Photovoltaics Visualization", page 36). If an SMA CT Meter is connected, additional slides will be available with information on household power consumption.

5.3.1 Slides without SMA CT Meter

Designation	Description
Overview	Provides an overview of the entire yield of the PV plant
Power and energy	Shows the current power of the PV plant, the daily energy and the total energy yield
Power chart	Shows the daily power of the PV plant
Yield estimate	Shows the total and daily remuneration for grid feed-in
CO ₂ avoidance	Shows the daily and overall amount of CO ₂ saved
Kilometers/miles saved	Shows the daily and overall number of kilometers/miles saved
Errors and warnings	<p>Appears automatically if an error or warning occurs</p> <p>An alarm sounds only when an error event occurs and the inverter stops feeding in (see Section 8.4 "Setting the Error Alert", page 29).</p> <ul style="list-style-type: none"> • Press the [Close] button to acknowledge the event. • Press the [Details] button to access the event list (see Section 7). <p>If not acknowledged, the alarm will sound again after the preset interval.</p>
Weather	<p>If meteorological data is available from the Internet, this slide shows the following meteorological data for the preset location:</p> <ul style="list-style-type: none"> • Current weather • Forecast for the next three days

5.3.2 Slide with SMA CT Meter

Designation	Description
Overview	Provides an overview of the entire yield of the PV plant
Current power overview	Shows the current power of the PV plant, the energy currently being used, the grid feed-in and the purchased electricity
Power chart	Shows the purchased electricity (gray), the grid feed-in (blue) and the self-consumption (green) of the PV plant yield (for the meanings of the colors, see Section 6)
Today's energy overview	Provides you with an overview of the purchased electricity (gray) as well as the amount of daily power (blue) and self-consumption (green) from the PV plant's daily yield
Yield estimate	Shows the total and daily remuneration for grid feed-in To calculate the remuneration, you must enter the feed-in tariff and the invoice amount in kWh (see Section 8.21 "Selecting Photovoltaics Visualization", page 36). By specifying the invoice amount, you can view the costs of purchasing electricity from the grid. The amount may deviate from the invoice of your power company.
Maximum daily consumption	Shows the current rate of daily consumption in relation to the target consumption rate You can set the target consumption rate (see Section 8.21).
CO ₂ avoidance	Shows the daily and overall amount of CO ₂ saved
Kilometers/miles saved	Shows the daily and overall amount of kilometers/miles saved.
Errors and warnings	Appears automatically if an error or warning occurs An alarm sounds only when an error event occurs and the inverter stops feeding in (see Section 8.4 "Setting the Error Alert", page 29). <ul style="list-style-type: none"> • Press the [Close] button to acknowledge the event. • Press the [Details] button to access the event list (see Section 7). If not acknowledged, the alarm will sound again after a preset interval.
Weather	If meteorological data is available from the Internet, this slide shows the following meteorological data for the preset location: <ul style="list-style-type: none"> • Current weather • Forecast for the next three days

5.4 Online Data

Requirement for displaying online data:

- An Internet connection must be established (see Section 8.17 "Setting up a WLAN Connection", page 34).

Newsfeeds and meteorological data are available online.

The Sunny View will display in each case the last ten messages that are not older than seven days. Control elements within the messages (e.g. hyperlinks) do not work. The displays can be activated or deactivated individually (see Section 8.19 "Configuring Online Data", page 35).

You **cannot** send data via the Internet using the Sunny View.

The online data changes after a set interval. To scroll through the data, drag your finger to the left or right.

Changing the Size of the Display

- To extend the display of the online data to the entire screen, tap on the online data you wish to view.
- To reduce the display size again, select [**Close**].

6 Charts Menu Item

The **Charts** menu item presents the yield of the entire PV plant or an individual inverter depending on the selected time period.

For Japan only: if the SMA CT Meter is connected via *Bluetooth*, the Sunny View also shows the self-consumption and the purchased electricity.

You can scroll through the daily, monthly and annual charts by dragging your finger to the left or right.

Procedure:

- You can call up the **Charts** menu item using  > **Charts** > **My PV plant**.

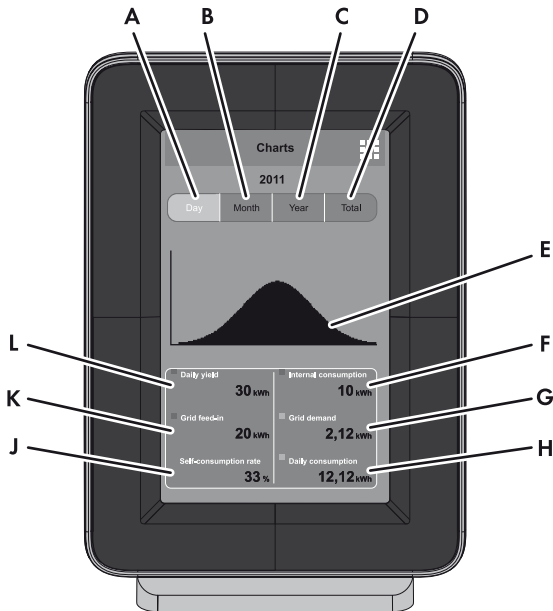

Figure 5: Chart layout

Item	Designation
A	Button for displaying the daily yield
B	Button for displaying the monthly yield
C	Button for displaying the annual yield
D	Button for displaying the total yield
E	Graph
F	Self-consumption*
G	Purchased electricity*

Item	Designation
H	Daily, monthly, annual or total consumption*
J	Self-consumption rate*
K	Grid feed-in*
L	Daily, monthly, annual or total yield**

* Requires the SMA CT Meter

** If not connected to the SMA CT Meter, the Sunny View also shows the current power in the daily chart.

Meaning of Graph Colors when SMA CT Meter Is Connected

Color	Description
Blue	Grid feed-in
Green	Self-consumption of electric current generated by the PV plant
Gray	Purchased electricity
Blue+green	Yield of the PV plant
Green+gray	Household consumption

7 Events Menu Item

The **Events** menu item shows all error messages, warnings and information.

Procedure:

- You can call up the **Events** menu item using  > **Events**.

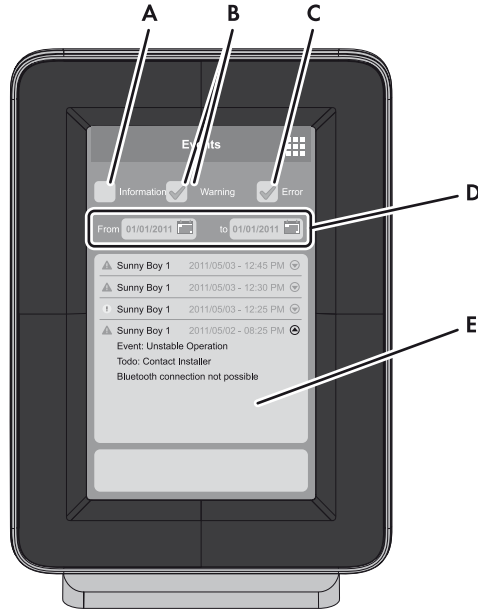

Figure 6: Layout of an event message

Item	Designation
A	Checkbox for displaying information
B	Checkbox for displaying warnings
C	Checkbox for displaying errors
D	Buttons for selecting the time frame
E	List of events









Event Types

Sunny View displays symbols to indicate the three types of event:

Type of event	Description
Error	The inverter is not working properly and is not feeding power into the grid. <ul style="list-style-type: none"> • Open the event details for more information. • Contact your installer and inform him about the event message and your inverter type.
Warning	The inverter is not working properly, but is still feeding power into the grid. The warning symbol is displayed if, for example, there is a frequent grid overvoltage.
Information	Settings have been configured on the inverter (e.g., parameters have been changed).

Symbols and Meaning of Event Types

- Incoming: the event has occurred.
- In progress: the event has existed for some time and could not yet be automatically remedied.
- Outgoing: the event has come to an end.

Symbol	Designation
	Error in progress
	Incoming error
	Outgoing error
	Warning in progress
	Incoming warning
	Outgoing warning
	Information in progress
	Incoming information
	Outgoing information

8 Settings Menu Item



8.1 Adjusting the Brightness of the Display

1. Select  > **Settings** > **General** > **Display**.
2. Drag the brightness slider to the right or left to adjust the brightness to the desired level.

8.2 Disabling the Display

You can disable the display or configure the settings in such a way that it disables automatically after a preset time. When disabled, the display is switched off. This means, the Sunny View requires less electric current.

Procedure:

1. Select  > **Settings** > **General** > **Display**.
2. Set the desired time period for disconnection.
3. If you would like to disconnect after a preset time:
 - Activate the **Off after** option.
 - Select the desired time in the appropriate drop-down list.
4. If you do not wish to configure any other settings, select .
 - After the preset time, the display will be disabled.
5. Simply touch the display to re-enable it.

8.3 Setting the Scaling of the Daily Graph

You can choose between static or dynamic scaling for the daily graph. If static scaling is selected, the graph can be scaled to a set maximum threshold (e.g., the maximum power of your PV plant). With dynamic scaling, the maximum thresholds of the measured values are used as the basis for scaling.

Procedure:

1. Select  > **Settings** > **General** > **Display**.
2. If you prefer static scaling for the daily graph:
 - Enable the **Static** option.
 - Enter the power of your PV plant in the appropriate text box.



Tip: You can reset the scaling to match the maximum power of your plant's inverter by pressing the **[Reset to nominal PV plant power]** button. This value can deviate from the actual maximum power of your PV plant.

3. If you prefer dynamic scaling for the daily chart, enable the **Dynamic** option.
4. If you do not wish to configure any other settings, select .



8.4 Setting the Error Alert

There is an error alarm when an error occurs. If the error is not eliminated, there will be another error alarm after a preset interval.



Procedure:

1. Select  > **Settings > General > Sounds**.
2. To enable the error alert, enable the **Error alert** checkbox.
3. To disable the error alert, disable the **Error alert** checkbox.
4. Select the repetition interval for the error alert in the "**Alarm sounds every**" drop-down list.
5. Drag the volume slider to the left or right until you reach the desired volume.
6. Select the desired alarm tone in the "**Alarm tone**" drop-down list.
7. If you do not wish to configure any other settings, select .



8.5 Setting the Key Clicks

1. Select  > **Settings > General > Sounds**.
2. To enable the key clicks, activate the **Key clicks** checkbox.
3. To disable the key clicks, deactivate the **Key clicks** checkbox.
4. Drag the volume slider to the left or right until you reach the desired volume.
5. If you do not wish to configure any other settings, select .



8.6 Identifying the Sunny View

1. Select  > **Settings > General > Information**.
 - A list containing the following information opens:
 - **Serial number**
 - **Firmware version**
 - **Hardware**
 - **Bluetooth version**
 - **WLAN Mac ID**
2. To return to the menu, select .

8.7 Setting the Language

1. Select  > **Settings > General > International > Language**.
2. Select the desired language.
3. If you do not wish to configure any other settings, select .

8.8 Setting the Country Settings

1. Select  > **Settings** > **General** > **International** > **Country**.
2. Select a country.
3. Check the country settings. Change the country settings if necessary.
Tip: Press the [**Reset**] button to restore the default country settings.
4. Select [**Next**].
5. If you do not wish to configure any other settings, select .

8.9 Setting the Date and Time

The Sunny View can synchronize the time automatically when a WLAN connection is available (see Section 8.17 "Setting up a WLAN Connection", page 34) and the **Automatic** checkbox is activated.

You can choose between a 12-hour or 24-hour time format by selecting the "**24-hour format**" checkbox accordingly.





Diagrams may be incorrectly displayed

Changing the set time while the inverters are feeding in can cause diagrams to be displayed with permanent errors.

- Only change the set time when the inverters are **not** feeding in (e.g., when it is dark).

Procedure:

1. Select  > **Settings** > **General** > **Date & time**.
2. In the field "**Time zone**", select the desired time zone.
3. In the field "**Date**", select the date.
4. Set the date using [+] and [-].
5. Select [**Accept**].
6. In the field "**Time**", select the time.
7. Set the time using [+] and [-].
8. Select [**Set**].
9. If you do not wish to configure any other settings, select .

8.10 Searching for a New PV Plant

If you want the Sunny View to monitor a different PV plant, you can search for a new PV plant.

Requirement:

- The PV plant can contain a maximum of twelve inverters.

Procedure:

1. Select  > **Settings** > **PV plant** > **New search** > **PV plant search**.
2. Select [**Search**].



Settings and CSV files

All Sunny View settings are saved. If a micro SDHC card is inserted, it will also contain the CSV files of the previous PV plant.

- The Sunny View searches for PV plants within its range.
 - The Sunny View shows all PV plants found in the search with their NetIDs.
3. Select the desired PV plant.
 4. Select [**Next**].



Possible restart of Sunny View

If the Sunny View was previously connected to another PV plant, it will restart itself.

5. Enter the PV plant password.
6. Select [**Next**].
7. If you want to use the 24-hour format for the time display, select the **24-hour format** checkbox.
8. Set the time zone, date format and time.
9. Select [**Next**].
10. Select the desired slides for the PV plant.
11. Select [**Next**].

8.11 Adding a New Device

If you are commissioning a new device and the Sunny View does not automatically add the device to the PV plant, you need to carry out a device search.

Requirements:

- The PV plant can contain a maximum of twelve inverters.
- The new device must have the same NetID as all the other PV plant devices (see manual for the *Bluetooth* device).

Procedure:

1. Select  > **Settings** > **PV plant** > **New search** > **Device search**.
 - The Sunny View lists the new devices.
2. Select the desired device.

3. Select **[Next]**.
4. Enable the **as a PV plant extension** option.
5. Select **[Next]**.
6. Enter the password for the new device.

Default password on delivery

The default password on delivery is 0000.

- The Sunny View connects with the new device and transfers the existing PV plant password to the new device.

7. Select **[Next]**.
8. Enter the device name.
9. Select **[Next]**.
10. If you want to add another device, select **[Add]** and proceed to Item 2.
11. Select **[Home]**.

8.12 Replacing a Device

If you want to replace existing devices with new devices, you will have to perform the device search in the Sunny View.

Requirement:

- The new device must have the same NetID as all the other PV plant devices (see manual for the *Bluetooth* device).

1. Select  > **Settings > PV plant > New search > Device search**.

2. Select **[Search]**.

- The Sunny View searches for devices within its range.

- The Sunny View shows all the devices in your PV plant that were found in the search.

3. Select the desired device.
4. Select **[Next]**.
5. Enable the **as a device replacement** option.
6. Select **[Next]**.
7. Select the device you want to replace.
8. Select **[Next]**.
9. Enter the device password.
10. Select **[Next]**.
11. Enter the PV plant password.
12. Select **[Next]**.
13. Enter the device name.
14. Select **[Next]**.
15. If you want to replace another device, select **[Add]**.
16. Select **[Home]**.

8.13 Changing the Device Name

The default name of the device is the serial number of the inverter. You can assign a unique name to the device.

Procedure:

1. Select  > **Settings** > **PV plant** > **Information**.
2. Select the desired device.
3. Select [**Device name**].
4. Enter a device name.
5. Select [**Next**].

8.14 What to Do in Case of a Lost PV Plant Password

If you forget the PV plant password, contact the SMA Service Line. You will be given a personal unlocking key (PUK) for each device, which can then be used to unblock the device. After you enter the PUK, the password for each device must be changed to a shared PV plant password (see Section 8.15). If you are not the PV plant owner, you must communicate the new password to the PV plant owner.

8.15 Changing the PV Plant Password

The PV plant password is used for all devices in the PV plant to prevent unauthorized access.

The PV plant password can have a maximum of twelve characters. The password may contain the following characters: A to Z, a to z, 0 to 9, ?, , _ , ! and - .







Procedure:

1. **Select** > **Settings** > **PV plant** > **PV plant** password.
2. Enter a new password in the "**Set password**" and "**Confirm password**" text boxes.
3. Select [**Accept**].

8.16 Displaying Connected Devices

1. Select  > **Settings > PV plant > Information.**

The Sunny View displays a list of connected devices with the following symbols:

Symbol	Status	Description
	Neutral	The status of the device is currently being updated.
	OK	The device is operational and working properly.
	Warning	The device is not working properly, but can still feed power to the grid.
	Error	The device is not working properly and does not feed power to the grid.
	Communication error	It is currently not possible to establish communication with the device. Possible causes include the overnight shutdown of the inverter.
	Lock	A password other than the PV plant password has been set for the device. Access to the device is not possible.

2. Select the desired device.

Sunny View displays the type, serial number and software version of the device.



8.17 Setting up a WLAN Connection

The WLAN router is used to establish a wireless connection to the Internet. You can define the interval at which the Sunny View updates online data. The WLAN connection is deactivated by default.

Router requirements:

- The router must support DHCP and DHCP must be enabled for the router.
- The router must support the transmission standard IEEE 802.11b or IEEE 802.11g.

Procedure:

1. Select  > **Settings > Wireless > Wi-Fi.**
2. Enable the **Wi-Fi** checkbox.
3. If the desired network is not displayed, search for the network:
 - Select [**Other networks**].
 - In the field "**Name**", enter the name of the network.
 - In the field "**Security**", select the desired encryption method.
 - Select [**Accept**].
4. If the network is password-protected, enter the password in the text box.
5. Using the drop-down list "**Refresh after**", set how often the Sunny View online data is updated from the Internet. For a fluent display of the slides, select a time period greater than five minutes.
6. If you do not wish to configure any other settings, select .

8.18 Checking and Setting Up a Bluetooth Connection

The connection of the Sunny View to your PV plant is established via *Bluetooth*. You can check the quality of your *Bluetooth* connection and the NetID, and set how often the Sunny View PV plant data is updated.



Radio range indoors

The radio range indoors depends on absorbent materials (e.g. walls) between the devices with SMA *Bluetooth*. In free-field conditions (i.e. without any obstacles), a radio range of up to 328 ft (100 m) can be achieved, whereas indoors it may be reduced to a few meters only. It is therefore not possible to specify the indoor radio range precisely. Tip: To improve the radio range, use one or more SMA *Bluetooth* Repeaters as required.

Procedure:

1. Select > **Settings** > **Wireless** > **Bluetooth**.
 The quality of the *Bluetooth* connection and the NetID is displayed.
2. Using the drop-down list "**Refresh after**", set how often the Sunny View online data is updated from the Internet. If you have more than six inverters, select a time period greater than five minutes.
3. If you do not wish to configure any other settings, select .

8.19 Configuring Online Data

1. Select > **Settings** > **Slide show** > **Online data**.
2. If you want a newsfeed:
 - Enable the **Newsfeed** checkbox.
 - Type the Internet address of the RSS feed or Atom feed in the "**URL**" text box.
3. If you want to display the weather:
 - Enable the **Weather** checkbox.
 - Enter the location and/or the country in the input field and confirm the search result by selecting it.
4. If you do not wish to configure any other settings, select .

8.20 Changing the Duration of the Slide Show

The slides in the slide show change after a preset display time.



Procedure:

1. Select > **Settings** > **Slide show**.
2. Select the desired display time in the "**Slide duration**" drop-down list.
3. If you do not wish to configure any other settings, select .

8.21 Selecting Photovoltaics Visualization

Sunny View shows the slide show only with slides that you have selected. For some slides you will need to specify additional information using the text boxes, drop-down menus and sliders. Tap the Info icon for more information. You will find an overview of the slides in the "PV plant data" section (see Section 5.3).

Procedure:

1. Select  > **Settings > Slide show > PV visualization**.
 - A list of all slides will open.
2. Select and enable the slides you want to display.
3. If you do not wish to configure any other settings, select .

8.22 Activating Demo Mode



The demo mode simulates the process of operating a PV plant. It can therefore be used to demonstrate how the Sunny View is operating. The Sunny View simulates a PV plant with a power of 4.5 kWp. If the country setting is set to Japan, the Sunny View will also simulate an SMA CT Meter.

Activating Demo Mode After Commissioning

Requirement:

- The Sunny View must not be connected to a PV plant.

Procedure:

1. Select  > **Settings > PV plant > New search > PV plant search**.
2. Select [**Demo mode**].
3. If you do not wish to configure any other settings, select .

9 Maintenance and Care

9.1 Safely Removing the Micro SDHC Card

Always remove the micro SDHC card as follows:

NOTICE

Damage to the micro SDHC card

If the micro SDHC card is removed while data is being written to it, it can be damaged and data can be lost.

- Safely removing the micro SDHC card

Procedure:

1. Call up the menu using .
2. In the lower section of the menu, select **Safely remove the SDHC card**.
 - The message "**The SDHC card can now be removed.**" appears.
3. Remove the micro SDHC card

9.2 Performing an Update

Perform an update so that the Sunny View can download the latest data. When the Sunny View is updated, all PV plant data and display settings will be saved.

Necessary equipment:

- Computer with Internet connection and a micro SDHC card slot
- microSDHC card with a maximum memory capacity of 8 GB

Procedure:

1. If you have not yet performed an update using the micro SDHC card, you must connect the micro SDHC card to the computer and create a folder labeled **UPDATE** on the micro SDHC card.
2. Download the update file in the download area of www.SMA-Solar.com and then save it on the micro SDHC card in the "**UPDATE**" folder.
3. Remove the micro SDHC card from the computer.
4. Push the micro SDHC card into the slot on the Sunny View.
5. Select  > **Settings > Service > Update**.
 - The following message appears: "**New update file found on the SDHC card. Do you wish to start the update?**"
 - Is the message not shown?
 - The microSDHC card was not recognized.
 - Ensure that the microSDHC card is inserted correctly in the card slot of the Sunny View.
 - Perform the update again.

The update file is defective or the microSDHC card is defective or unsuitable.

- Ensure that the microSDHC card has a maximum memory capacity of 8 GB.
- Perform the update again.
- If the update fails after several attempts, contact the SMA Service Line.

6. Select [**Start update**].

The update procedure starts. The Sunny View displays the message "**Update successful!**" and restarts.

"**Update failed!**" message appears on the display.

The update file or micro SDHC card is defective.

- Perform the update again.
- If the update fails after several attempts, contact the SMA Service Line.

NOTICE

Damage of the Sunny View due to disconnection from the electricity supply

Disconnecting the Sunny View from the electricity supply during the update procedure or when restarting may damage the Sunny View.

- **Do not** remove the plug-in power supply from the outlet during the update procedure or when restarting.

9.3 Restoring Factory Settings

If you restore the default setting of the Sunny View, note that all PV plant data and display settings will be deleted. The saved PV plant data and CSV files remain intact on the micro SDHC card.

Restoring the factory settings can take several minutes.

Procedure:

1.  Select **> Settings > Service > Factory settings**.

The following message appears: "**After a reset to factory settings, your PV plant data and settings are deleted.**"

2. Select [**Reset**].

9.4 Generating a Back-Up File

When you generate a back-up file, the Sunny View will save all PV plant data and settings to your micro SDHC card. A back-up file will allow you to restore all your data when you replace the Sunny View or reset the device to the factory settings.

You can generate back-up files either automatically or manually. In automatic mode, the Sunny View will automatically generate a back-up file at regular intervals.

Requirement:

- A micro SDHC card must be inserted in the slot.

Procedure:

1. Select  > **Settings** > **Service** > **Back-up file** > **Generate back-up file**.
2. If you prefer automatic back-up creation:
 - Select the option **automatically**.
 - Select the desired interval from the drop-down list.
3. If you would like to generate a back-up file manually, activate the option **manually**.
4. Select [**Next**].
 - The following message appears: "**Back-up file was generated successfully!**"
 - The following message appears: "**Please insert an SDHC card with at least xx MB free space.**"

The micro SDHC card does not have enough memory available or is not inserted into the device.

- Insert a micro SDHC card with sufficient memory.
- Select [**Repeat**].

9.5 Restoring Sunny View Data from a Back-up File

Overwriting PV plant data and settings

When you restore a back-up, all PV plant data and settings are overwritten.

Requirement:

- A micro SDHC card containing the back-up file must be inserted in the slot.

Procedure:

1. Select  > **Settings** > **Service** > **Back-up file** > **Restore from back-up file**.
 - The following message appears: "**Do you want to restore the back-up file with all data and settings on this Sunny View?**"
2. Select [**Restore**].
 - The following message appears: "**The data and settings were successfully restored from the back-up file!**"
 - The following message appears: "**No back-up file found.**"
 - Make sure that a micro SDHC card with the back-up file is inserted into the device.

10 Decommissioning

10.1 Decommissioning the Sunny View

- Remove the plug-in power supply from the Sunny View and the outlet.

10.2 Disposing of the Sunny View

- Dispose of the Sunny View in accordance with the disposal regulations for electronic waste applicable at the installation site.

11 Troubleshooting

Problem	Cause
Sunny View does not list the NetID of your PV plant.	<p>In your PV plant, no device is within the radio range of the Sunny View.</p> <p>Corrective measures:</p> <ul style="list-style-type: none"> Reduce the distance between the Sunny View and the PV plant device. <hr/> <p>Devices of your PV plant are not in operation.</p> <p>Corrective measures:</p> <ul style="list-style-type: none"> Commission the devices. <hr/> <p>The NetID 0 (<i>Bluetooth off</i>) is set for the devices.</p> <p>Corrective measures:</p> <ul style="list-style-type: none"> Set the NetID of your PV plant for the devices.
Sunny View does not list all the devices of your PV plant.	<p>Sunny View completed the PV plant search before all devices were connected to one another. For PV plants with many devices, it may take several minutes until all devices are connected to one another.</p> <p>Corrective measures:</p> <ul style="list-style-type: none"> Repeat the PV plant search. <hr/> <p>Not all devices are connected to one another. The wireless connection of several devices may be disturbed by ambient conditions.</p> <p>Corrective measures:</p> <ul style="list-style-type: none"> Check the connection quality of the devices (see the respective manual). The connection quality of all devices must at least be "good". <hr/> <p>Not all devices are connected to one another. In certain devices, the NetID of your PV plant may not be set.</p> <p>Corrective measures:</p> <ul style="list-style-type: none"> Make sure that the NetID of your PV plant is configured on the devices.

Problem	Cause
Sunny View does not list all the devices of your PV plant.	<p>Inverters with retrofitted SMA <i>Bluetooth</i> Piggy-Back (if applicable) shut down overnight. Therefore, the Sunny View cannot establish a connection to these inverters at night.</p> <p>Corrective measures:</p> <ul style="list-style-type: none"> As soon as the inverters switch on in the morning, the Sunny View is able to establish a connection to them.
The Sunny View lists your own and other inverters.	<p>A different <i>Bluetooth</i> plant within the radio range of the Sunny View uses the same NetID as your <i>Bluetooth</i> plant.</p> <p>Corrective measures:</p> <ul style="list-style-type: none"> Determine a free NetID for your PV plant and configure it on all devices.
The Sunny View is not connecting with the <i>Bluetooth</i> devices.	<p>A different NetID is configured for the Sunny View than for the other <i>Bluetooth</i> devices.</p> <p>Corrective measures:</p> <ul style="list-style-type: none"> Make sure that the NetID configured on the Sunny View is the same as on the other <i>Bluetooth</i> devices.
	<p>There are too many masters in the <i>Bluetooth</i> plant (e.g. Sunny Beam, Sunny WebBox with <i>Bluetooth</i>).</p> <p>Corrective measures:</p> <ul style="list-style-type: none"> For PV plants with up to two inverters, a maximum of two masters can be used. For PV plants with three or more inverters, a maximum of four masters can be used.
<i>Bluetooth</i> connection quality of the Sunny View is not at least "Good".	<p>The Sunny View is too far away from your PV plant, or there is interference with the wireless connection. Disturbances can be caused by, for example, walls or ceilings that shield the wireless signal too effectively.</p> <p>Corrective measures:</p> <ul style="list-style-type: none"> Place the Sunny View closer to a device of your PV plant.
	<p>Instead of the plug-in power supply provided, you are using a plug-in power supply that is not suitable for the Sunny View.</p> <p>Corrective measures:</p> <ul style="list-style-type: none"> Use only the plug-in power supply provided.

Problem	Cause
An alarm can be heard.	<p>An error has occurred in an inverter.</p> <p>Corrective measures:</p> <ul style="list-style-type: none"> • Call up the error details. • Contact your installer and inform him/her about the event message and the serial number of the inverter in which the event occurred. <p>Tip: If you no longer wish to be notified of errors, you can switch off the alarm sound (see Section 8.4 "Setting the Error Alert", page 29).</p>
Alarm cannot be heard even though an error has occurred.	<p>The alarm is disabled or the volume is too low.</p> <p>Corrective measures:</p> <ul style="list-style-type: none"> • Set the alarm sound (see Section 8.4). <p>Instead of the plug-in power supply provided, you are using a plug-in power supply that is not suitable for the Sunny View.</p> <p>Corrective measures:</p> <ul style="list-style-type: none"> • Use only the plug-in power supply provided.
The display does not switch on.	<p>Corrective measures:</p> <ul style="list-style-type: none"> • Check the grid connection. <p>Instead of the plug-in power supply provided, you are using a plug-in power supply that is not suitable for the Sunny View.</p> <p>Corrective measures:</p> <ul style="list-style-type: none"> • Use only the plug-in power supply provided.
The update is not possible.	<p>The microSDHC card was not recognized.</p> <p>Corrective measures:</p> <ul style="list-style-type: none"> • Ensure that the microSDHC card is inserted correctly in the card slot of the Sunny View. • Perform the update again. <p>The update file is defective or the microSDHC card is defective or unsuitable.</p> <p>Corrective measures:</p> <ul style="list-style-type: none"> • Ensure that the microSDHC card has a maximum memory capacity of 8 GB. • Perform the update again. • If the update fails after several attempts, contact the SMA Service Line.

Problem	Cause
None or only some of the online data is displayed.	<p>WLAN connection is not active.</p> <p>Corrective measures:</p> <ul style="list-style-type: none"> • Make sure the router is switched on. • Make sure the router supports DHCP. • Make sure DHCP is enabled for the router. • Check the WLAN connection (see Section 8.17) and your access data (see Section 8.15).
	<p>The WLAN connection is too weak. The wireless connection may be disturbed by ambient conditions.</p> <p>Corrective measures:</p> <ul style="list-style-type: none"> • Check the quality of the WLAN connection on the Sunny View. Place the Sunny View closer to the router if necessary.
	<p>Online data is not enabled.</p> <p>Corrective measures:</p> <ul style="list-style-type: none"> • Make sure that online data is configured properly (see Section 8.19).
	<p>Instead of the plug-in power supply provided, you are using a plug-in power supply that is not suitable for the Sunny View.</p> <p>Corrective measures:</p> <ul style="list-style-type: none"> • Use only the plug-in power supply provided.
Consumption data is not properly displayed or not displayed at all (only valid in Japan for PV plants with SMA CT Meter).	<p>The SMA CT Meter is not connected properly or the Bluetooth connection is too weak.</p> <p>Corrective measures:</p> <ul style="list-style-type: none"> • Reduce the distance between the Sunny View and the SMA CT Meter. • Make sure the SMA CT Meter is installed properly (see installation manual of the SMA CT Meter).
Diagrams are displayed with gaps or pointed forms.	<p>After commissioning the Sunny View, the time in the Sunny View was set ahead or behind.</p> <p>This only affects the diagram display, not the calculated energy values.</p>

Problem	Cause
The Home slides do not change.	<p data-bbox="403 175 1012 215">Only one slide is activated.</p> <p data-bbox="403 223 1012 263">Corrective measures:</p> <ul data-bbox="403 263 1012 327" style="list-style-type: none"> <li data-bbox="403 263 1012 327">• Select other slides for display (see Section 8.21 "Selecting Photovoltaics Visualization", page 36).
Unable to activate demo mode.	<p data-bbox="403 327 1012 406">Demo mode is only available when the Sunny View is not connected to a PV plant.</p> <p data-bbox="403 414 1012 454">Corrective measures:</p> <ul data-bbox="403 454 1012 568" style="list-style-type: none"> <li data-bbox="403 454 1012 568">• Restore the factory settings (see Section 9.3). IMPORTANT: If you restore the factory settings of the Sunny View, all PV plant data and display settings will be deleted.

12 Technical Data

Mechanical Data

Width x height x depth without tabletop stand	151.9 mm x 109 mm x 23.5 mm (5.98 in. x 4.29 in. x 0.93 in.)
Width x height x depth with tabletop stand	151.9 mm x 109 mm x 25.5 mm (5.98 in. x 4.29 in. x 1 in.)
Weight without tabletop stand	245 g (8.64 oz.)
Weight with tabletop stand	293 g (10.34 oz.)
Certified countries	Australia, Belgium, Denmark, Germany, France, Greece, Great Britain, Italy, Japan, Canada, Austria, Switzerland, USA

Voltage Supply

Voltage supply	Plug-in power supply
Input voltage	90 V _{AC} to 240 V _{AC} , 50 Hz/ 60 Hz
Typical power consumption	3.75 W
Maximum power consumption	8 W
Maximum current consumption	1.6 A

Ambient Conditions

Ambient temperature	0°C to +40°C (+32°F to +104°F)
Humidity, non-condensing	5% to 95%
Degree of protection* / NEMA class	IP20 / NEMA 1
Mounting location	Indoors

* Degree of protection as per IEC 60529

Communication

Inverter communication	Bluetooth Wireless Technology Class 1
Maximum number of inverters	12
Maximum number of devices - SMA CT Meter	1
Maximum range in free-field conditions	100 m (328 ft.)

Equipment	
Display	LCD
Resolution	480 px x 800 px
Operation	Touch screen
Storage system	Ring buffer*
Internal memory for PV plant data	16 MB
Type of SDHC card	microSD
Minimum memory of the micro SDHC card	512 MB
Recommended maximum memory of the micro SDHC card	8 GB
Amount of data that can be stored retrospectively from the Sunny View to the micro SDHC card after the card is inserted.	Daily yields: 90 days Monthly yields: 30 years Events: 200

* Always contains the last 13 monthly files and 90 daily files

13 Compliance Information

FCC Compliance

This device complies with Part 15 of the FCC Rules. Operation is subject to the following conditions:

1. This device may not cause harmful interference, and
2. This device must accept any interference received, including interference that may cause undesired operation.

NOTE: This equipment has been tested and found to comply with the limits for a Class B digital device, pursuant to Part 15 of the FCC Rules. These limits are designed to provide reasonable protection against harmful interference in a residential installation. This equipment generates, uses, and can radiate radio frequency energy and if not installed and used in accordance with the instructions, may cause harmful interference to radio communications. However, there is no guarantee that interference will not occur in a particular installation. If this equipment does cause harmful interference to radio or television reception, which can be determined by turning the equipment off and on, the user is encouraged to try to correct the interference by one or more of the following measures:

- Reorient or relocate the receiving antenna.
- Increase the separation between the equipment and the receiver.
- Connect the equipment into an outlet on a circuit different from that to which the receiver is connected.
- Consult the dealer or an experienced radio/TV technician for help.

The user is cautioned that changes or modifications not expressly approved by SMA America, LLC could void the user's authority to operate this equipment.

This equipment complies with FCC radiation exposure limits set forth for an occupational environment. This equipment should be installed and operated with minimum distance of 8 in. (20 cm) between the radiator and your body.

IC Compliance

This device complies with Industry of Canada licence-exempt RSS standard(s). Operation is subject to the following two conditions:

- This device may not cause interference, and
- This device must accept any interference, including interferences that may cause undesired operation of the device.

This equipment complies with Canada radiation exposure limits set forth for uncontrolled environments in accordance with RSS-102. This transmitter must not be co-located or be operated in conjunction with any other antenna or transmitter. This equipment should be installed and operated with minimum distance of 8 in. (20 cm) between the radiator and your body.

14 Contact

If you have technical problems concerning our products, contact the SMA Service Line. We require the following data in order to provide you with the necessary assistance:

- Sunny View:
 - Hardware version
 - Firmware version
- SMA CT Meter (if present):
 - Hardware version
 - Firmware version
- SMA Bluetooth Piggy-Back in the inverter (if present):
 - Firmware version
- Inverters:
 - Device type
 - Serial number

Australia	SMA Australia Pty Ltd. Sydney	Toll free for Australia:	1800 SMA AUS (1800 762 287)
		International:	+61 2 9491 4200
Belgien/ Belgique/ België	SMA Benelux BVBA/SPRL Mechelen	+32 15 286 730	
Brasil	Vide España (Espanha)		
Česko	SMA Central & Eastern Europe s.r.o. Praha	+420 235 010 417	
Chile	Ver España		
Danmark	Se Deutschland (Tyskland)		

Deutschland	SMA Solar Technology AG Niestetal	Medium Power Solutions Wechselrichter: +49 561 9522-1499 Kommunikation: +49 561 9522-2499 SMA Online Service Center: www.SMA.de/Service
		Hybrid Energy Solutions Sunny Island: +49 561 9522-399 PV-Diesel +49 561 9522-3199 Hybridsysteme:
		Power Plant Solutions Sunny Central: +49 561 9522-299
España	SMA Ibérica Tecnología Solar, S.L.U. Barcelona	Llamada gratuita en España: 900 14 22 22 Internacional: +34 902 14 24 24
France	SMA France S.A.S. Lyon	Medium Power Solutions Onduleurs : +33 472 09 04 40 Communication : +33 472 09 04 41
		Hybrid Energy Solutions Sunny Island : +33 472 09 04 42
		Power Plant Solutions Sunny Central : +33 472 09 04 43
India	SMA Solar India Pvt. Ltd. Mumbai	+91 22 61713888
Italia	SMA Italia S.r.l. Milano	+39 02 8934-7299
Κύπρος/ Kıbrıs	Βλέπε Ελλάδα/ Bkz. Ελλάδα (Yunanistan)	
Luxemburg/ Luxembourg	Siehe Belgien Voir Belgique	
Magyarország	lásd Česko (Csehország)	
Nederland	zie Belgien (België)	
Österreich	Siehe Deutschland	
Perú	Ver España	
Polska	Patrz Česko (Czechy)	

Portugal	SMA Solar Technology Portugal, Unipessoal Lda Lisboa	Gratuito em Portugal: Internacional:	800 20 89 87 +351 2 12 37 78 60
România	Vezi Česko (Cehia)		
Schweiz	Siehe Deutschland		
Slovensko	pozri Česko (Česká republika)		
South Africa	SMA Solar Technology South Africa Pty Ltd. Centurion (Pretoria)	08600 SUNNY (08600 78669) International:	+27 (12) 643 1785
United Kingdom	SMA Solar UK Ltd. Milton Keynes	+44 1908 304899	
Ελλάδα	SMA Hellas AE Αθήνα	801 222 9 222 International:	+30 212 222 9 222
България	Вижте Ελλάδα (Γърция)		
ไทย	SMA Solar (Thailand) Co., Ltd. กรุงเทพฯ	+66 2 670 6999	
대한민국	SMA Technology Korea Co., Ltd. 서울	+82 2 508-8599	

+971 2 234-6177

SMA Middle East LLC

أبو ظبي

الإمارات
العربية المتحدة

Other countries	International SMA Service Line Niestetal	Toll free worldwide: 00800 SMA SERVICE (+800 762 7378423)
United States/ Estados Unidos	SMA America, LLC Rocklin, CA	+1 877-MY-SMATech (+1 877-697-6283)* +1 916 625-0870**
Canada/ Canada	SMA Canada, Inc. Toronto	+1 877-MY-SMATech (+1 877-697-6283)***

* toll free for USA, Canada and Puerto Rico / Llamada gratuita en EE. UU., Canadá y Puerto Rico

** international / internacional

*** toll free for Canada / gratuit pour le Canada

SMA Solar Technology

www.SMA-Solar.com

