



SUNNY TRIPOWER 125

Legal Provisions

The information contained in these documents is the property of . No part of this document may be reproduced, stored in a retrieval system, or transmitted, in any form or by any means, be it electronic, mechanical, photographic, magnetic or otherwise, without the prior written permission of . Internal reproduction used solely for the purpose of product evaluation or other proper use is allowed and does not require prior approval.

makes no representations or warranties, express or implied, with respect to this documentation or any of the equipment and/or software it may describe, including (with no limitation) any implied warranties of utility, merchantability, or fitness for any particular purpose. All such representations or warranties are expressly disclaimed. Neither nor its distributors or dealers shall be liable for any indirect, incidental, or consequential damages under any circumstances.

The exclusion of implied warranties may not apply in all cases under some statutes, and thus the above exclusion may not apply.

Specifications are subject to change without notice. Every attempt has been made to make this document complete, accurate and up-to-date. Readers are cautioned, however, that product improvements and field usage experience may cause to make changes to these specifications without advance notice or per contract provisions. shall not be responsible for any damages, including indirect, incidental or consequential damages, caused by reliance on the material presented, including, but not limited to, omissions, typographical errors, arithmetical errors or listing errors in the content material.

SMA Warranty

You can download the current warranty conditions from the Internet at www.SMA-Solar.com.

Trademarks

All trademarks are recognized, even if not explicitly identified as such. Missing designations do not mean that a product or brand is not a registered trademark.

SMA Solar Technology AG

Sonnenallee 1

34266 Niestetal

Germany

Tel. +49 561 9522-0

www.SMA.de

E-mail: info@SMA.de

Status: Monday, March 23, 2026

Copyright © 2026 . All rights reserved.

Table of contents

1	Information on this Document.....	7
1.1	Validity.....	7
1.2	Target Group	7
1.3	Content and Structure of this Document.....	7
1.4	Levels of Warning Messages.....	7
1.5	Symbols in the Document.....	8
1.6	Typographies in the document.....	8
1.7	Designations in the Document.....	8
1.8	Additional Information.....	8
2	Safety	10
2.1	Intended Use.....	10
2.2	IMPORTANT SAFETY INFORMATION	10
3	Scope of delivery	14
4	Additionally Required Materials and Equipment.....	16
5	Product overview	18
5.1	Product Description.....	18
5.2	Symbols on the Product.....	18
5.3	Interfaces and Functions.....	20
5.3.1	User Interface	20
5.3.2	Arc-Fault Circuit Interrupter (AFCI)	20
5.3.3	Modbus	20
5.3.4	Grid Management Services	20
5.3.5	Zero export.....	20
5.3.6	Fast stop function.....	20
5.3.7	SMA ShadeFix	21
5.3.8	SMA Smart Connected.....	21
5.3.9	SMA Speedwire.....	21
5.3.10	SMA Webconnect	21
5.3.11	Wi-Fi connection to SMA 360° app and SMA Energy app.....	21
5.3.12	Wi-Fi.....	22
5.4	LED Signals.....	22
5.5	System overview	23
5.6	Block circuit diagram of the inverter	23
6	Mounting	24
6.1	Requirements for Mounting.....	24
6.1.1	Requirements for the Mounting Location	24
6.1.2	Permitted and prohibited mounting positions	24
6.1.3	Recommended clearances	25
6.2	Mounting to Profile Rails	25
6.2.1	Requirements for mounting on profile rails	25
6.2.2	Mounting the Product to Profile Rails	26
6.3	Mounting the Product on a Wall	28
7	Opening the Cable Compartment	31
8	Installing Optional AC Sealing Plate	32
9	Electrical Connection.....	33
9.1	Requirements for the electrical connection.....	33

9.1.1	Permitted grid configurations.....	33
9.1.2	Residual-current monitoring unit	33
9.1.3	Load-break switch and cable protection.....	34
9.1.4	Equipotential Bonding.....	34
9.1.5	AC cable requirements	34
9.1.6	Network cable requirements	34
9.1.7	DC cable requirements	35
9.1.8	Signal cable requirements	35
9.2	Overview of the Connection Area.....	35
9.2.1	View from Below	35
9.2.2	Interior View	36
9.2.3	Overview of the COM assembly connections	37
9.3	Electrical connection procedure	37
9.4	Connecting the Inverter to the Utility Grid.....	37
9.5	Connecting the external protective grounding	40
9.6	Connecting the Network Cables	40
9.7	Connection for Active Power Limitation.....	42
9.7.1	Procedure for Connecting the Active Power Limitation	42
9.7.2	Digital input DI: D1-D4, Vcc	42
9.7.3	Pin assignment DI: D1-D4, Vcc.....	42
9.7.4	Circuitry overview DI: D1-D4, Vcc	42
9.7.5	Connecting the Digital Input DI: D1-D4, Vcc.....	43
9.8	Connection for Digital Fast-Stop Inputs	43
9.8.1	Procedure for Connecting to the Fast-Stop Input.....	43
9.8.2	Pin assignment for fast stop	44
9.8.3	Fast stop circuitry overview to realize the grid and PV system protection.....	45
9.8.4	Fast stop circuitry overview for universal applications.....	45
9.8.5	Connecting contact for fast stop to digital input	45
9.9	Connection to the Multifunction Relay	47
9.9.1	Procedure for Connecting the Multifunction Relay	47
9.9.2	Pin assignment for multifunction relay	47
9.9.3	Application Examples	48
9.9.3.1	Using the Multifunction Relay as a Fault Indicator Contact.....	48
9.9.3.2	Controlling loads via the multifunction relay or charging batteries depending on the power production of the PV system.....	49
9.9.3.3	Reporting the switching status of the grid relay.....	50
9.9.4	Connecting the Multifunction Relay	50
9.10	DC connection	51
9.10.1	Overview of DC connectors	51
9.10.2	Assembling the DC Connectors.....	52
9.10.3	Connecting the PV Array	53
10	Commissioning	56
10.1	Procedure for commissioning in systems without System Manager	56
10.2	Procedure for commissioning in systems with System Manager.....	56
10.3	Switching the Inverter On.....	57
10.4	Carry out the configuration using the installation assistant	57
10.5	Adopting the Configuration from a File.....	58
10.6	Carry out the configuration manually.....	58
11	Operation	59
11.1	Establishing a Connection to the User Interface	59
11.1.1	Establishing a Direct Connection via Ethernet	59
11.1.2	Direct connection via Wi-Fi.....	59
11.1.2.1	Connection options for Wi-Fi direct connection	59

11.1.2.2	Requirements for Direct Connection via Wi-Fi	59
11.1.2.3	Access information for direct Wi-Fi connection	60
11.1.2.4	Establishing a direct Wi-Fi connection with the 360° app.....	60
11.1.2.5	Establishing direct Wi-Fi connection with Wi-Fi network search.....	60
11.1.3	Connection in the local network.....	61
11.1.3.1	Access addresses for the product in the local network.....	61
11.1.3.2	Establishing a Connection via Ethernet in the local network	61
11.1.3.3	Establishing a Connection via Wi-Fi in the Local Network.....	61
11.2	Layout of the 'Configuring the Inverter' page.....	62
11.3	Layout of the installation assistant.....	63
11.4	Start Page Design of the User Interface	64
11.5	Access rights to the user interface.....	66
11.6	Logging into the user interface for the first time	66
11.7	Creating a user password.....	67
11.8	Logging Into the User Interface.....	67
11.9	Logging out of the user interface	67
11.10	Starting the Installation Assistant.....	68
11.11	Changing parameters.....	68
11.12	Activating the WPS Function	69
11.13	Switching WLAN Off.....	69
11.14	Switching WLAN On.....	69
11.15	Configuring the active power mode for systems with external setpoint.....	69
11.16	Configuring the active power mode for systems with manual setpoint	70
11.17	Arc-Fault Circuit Interrupter (AFCI).....	70
11.18	Generating a product key for the first time	71
11.19	Generate new product key	72
11.20	Activate Service access	72
11.21	Deactivate Service access.....	73
11.22	Password.....	73
11.23	Dynamic power display (green LED).....	73
11.24	Q on Demand 24/7	74
11.25	Saving the Configuration in a File	74
11.26	Adopting a Configuration from a File	75
11.27	Configuring the Country Data Set	75
11.28	Automatic firmware update.....	75
11.29	Updating firmware via the user interface.....	76
11.30	Operating Modes of the Multifunction Relay	76
11.31	Changing the Operating Mode of the Multifunction Relay.....	77
11.32	Setting the fast-stop function with external switch.....	77
11.33	Configuring the fast stop for the external grid and PV system protection function.....	77
11.34	Setting SMA ShadeFix	78
12	Disconnecting the Inverter from Voltage Sources.....	79
13	Troubleshooting	81
13.1	Overview of the designations for MPP trackers.....	81
13.2	Event messages.....	81
14	Maintenance.....	103
14.1	Safety during Maintenance	103

14.2	Servicing Schedule	103
14.3	Cleaning	104
14.4	Removing the Fan Assembly	104
14.5	Installing the External Fan Assembly	105
15	Decommissioning	106
15.1	Disconnecting the Terminals from the Inverter	106
15.2	Disassembling the DC Connectors	107
15.3	Disassembling the Inverter	108
16	Disposal	110
17	Technical Data	111
17.1	General Data	111
17.2	DC Input	112
17.3	AC Output	112
17.4	Efficiency	113
17.5	Protective devices	113
17.6	Equipment	113
18	Contact	114
19	EU Declaration of Conformity	115

1 Information on this Document

1.1 Validity

This document is valid for:

- STP 125-70 (Sunny Tripower 125)

1.2 Target Group

The tasks described in this document must only be performed by qualified persons. Qualified persons must have the following skills:

This document is intended for qualified persons and end users. Only qualified persons are allowed to perform the activities marked in this document with a warning symbol and the caption "Qualified person". Tasks that do not require any particular qualification are not marked and can also be performed by end users. Qualified persons must have the following skills:

- Knowledge of how to safely disconnect SMA inverters
- Knowledge of how an inverter works and is operated
- Training in how to deal with the dangers and risks associated with installing, repairing and using electrical devices and installations
- Training in the installation and commissioning of electrical devices and installations
- Knowledge of all applicable laws, regulations, standards, and directives
- Knowledge of and compliance with this document and all safety information

1.3 Content and Structure of this Document

This document describes the mounting, installation, commissioning, configuration, operation, troubleshooting and decommissioning of the product.

The latest version of this document and additional information about the product can be found in PDF format and as an eManual at www.SMA-Solar.com. You can also call up the eManual via the user interface of the product.

Illustrations in this document are reduced to the essential information and may deviate from the real product.

1.4 Levels of Warning Messages

The following levels of warning messages may occur when handling the product.

DANGER

Indicates a hazardous situation which, if not avoided, will result in death or serious injury.

WARNING

Indicates a hazardous situation which, if not avoided, could result in death or serious injury.



CAUTION

Indicates a hazardous situation which, if not avoided, could result in minor or moderate injury.

NOTICE

Indicates a situation which, if not avoided, can result in property damage.

1.5 Symbols in the Document

Symbol	Explanation
	Information that is important for a specific topic or goal, but is not safety-relevant
<input type="checkbox"/>	Indicates a requirement for meeting a specific goal
<input checked="" type="checkbox"/>	Required result
	Example
 QUALIFIED PERSON	Sections describing activities to be performed by qualified persons only

1.6 Typographies in the document

Typography	Use	Example
bold	<ul style="list-style-type: none"> Messages Terminals Elements on a user interface Elements to be selected Elements to be entered 	<ul style="list-style-type: none"> Connect the insulated conductors to the terminals X703:1 to X703:6. Enter 10 in the field Minutes.
>	<ul style="list-style-type: none"> Connects several elements to be selected 	<ul style="list-style-type: none"> Go to Settings > Date.
[Button]	<ul style="list-style-type: none"> Button or key to be selected or pressed 	<ul style="list-style-type: none"> Select [Enter].
[Key]		
#	<ul style="list-style-type: none"> Placeholder for variable components (e.g., parameter names) 	<ul style="list-style-type: none"> Parameter WCtHz.Hz#

1.7 Designations in the Document

Complete designation	Designation in this document
Sunny Tripower 125-70	Sunny Tripower, inverter, product

1.8 Additional Information

Additional information is available at www.SMA-Solar.com.

Title and information content	Type of information
	Technical Information
	Technical Information
Efficiency and derating behavior of the SMA inverters	Technical Information
	Technical Information
	Technical Information

Title and information content	Type of information
Device-specific overview of all parameters and measured values and their setting options Information about the SMA Modbus registers	Technical Information
"SMA MODBUS" Information on the SMA Modbus interface as well as an overview of all SMA Modbus registers	Technical Information
	Technical Information
Answers to frequently asked questions	FAQ on product page
"TechTip: Mounting and Installing Sunny Tripower 125"	Video 

2 Safety

2.1 Intended Use

The Sunny Tripower is a transformerless PV inverter with 12 MPP trackers that converts the direct current of the PV modules to grid-compliant three-phase current and feeds it into the utility grid.

The product is intended for use in industrial environments.

The product must only be accessible to qualified persons.

The product complies with EN 55011 of class A, group 1:

- a.c. mains power port: ≤ 20 kVA
- d.c. power port: > 75 kVA
- Electromagnetic radiation disturbance: ≤ 20 kVA

In accordance with EN 55011, the product must only be operated at locations where the distance between the product and third-party radio-communication installations is greater than .

This product is not intended for use in residential environments and may not provide adequate protection to radio reception in such environments.

The product is suitable for indoor and outdoor use.

All components must remain within their permitted operating ranges and their installation requirements at all times.

The product must only be used in countries for which it is approved or released by and the grid operator.

The products by are not suitable for use in

- Medical devices, in particular products for supplying life-support systems and machines,
- Aircraft, the operation of aircraft, the supply of critical airport infrastructure and airport systems,
- Rail vehicles, the operation and supply of rail vehicles and their critical infrastructure.

The above list is not exhaustive. Contact us if you are unsure whether products by are suitable for your application.

The documentation must be strictly followed. Deviations from the described actions and the use of materials, tools, and aids other than those specified by are expressly forbidden.

Any use of the product other than that described in the Intended Use section does not qualify as appropriate.

The documentation supplied is an integral part of SMA products. Keep the documentation in a convenient, dry place for future reference and observe all instructions contained therein.

This document does not replace any regional, state, provincial, federal or national laws, regulations or standards that apply to the installation, electrical safety and use of the product. assumes no responsibility for the compliance or non-compliance with such laws or codes in connection with the installation of the product.

The type label must remain permanently attached to the product.

The product is not equipped with an integrated transformer and therefore has no galvanic isolation. The product must not be operated with PV modules whose outputs are grounded. This can cause the product to be destroyed. The product may be operated with PV modules whose frame is grounded.

PV modules with a high capacity to ground must only be used if the coupling capacity of all PV modules does not exceed .

2.2 IMPORTANT SAFETY INFORMATION

Keep the manual for future reference.

This section contains safety information that must be observed at all times when working.

The product has been designed and tested in accordance with international safety requirements. As with all electrical or electronical devices, some residual risks remain despite careful construction. To prevent personal injury and property damage and to ensure long-term operation of the product, read this section carefully and observe all safety information at all times.

⚠ DANGER**Danger to life due to electric shock when live components are touched on opening the product**

High voltages are present in the live parts and cables inside the product during operation. Touching live parts and cables results in death or lethal injuries due to electric shock.

- Do not open the product during operation.
- Disconnect the product from voltage sources and ensure it cannot be reconnected before working on the device.

⚠ DANGER**Danger to life due to electric shock when touching live system components in case of a ground fault**

If a ground fault occurs, parts of the system may still be live. Touching live parts and cables results in death or lethal injuries due to electric shock.

- Disconnect the product from voltage sources and ensure it cannot be reconnected before working on the device.
- Only touch the cables of the PV modules on their insulation.
- Do not touch any parts of the substructure or frame of the PV array.
- Do not connect PV strings with ground faults to the inverter.

⚠ DANGER**Danger to life due to electric shock in case of overvoltages and if surge protection is missing**

Overvoltages (e.g., in the event of a flash of lightning) can be further conducted into the building and to other connected devices in the same network via the network cables or other data cables if there is no surge protection. Touching live parts and cables results in death or lethal injuries due to electric shock.

- Ensure that all devices in the same network are integrated in the existing overvoltage protection.
- When laying the network cable outdoors, ensure that there is suitable surge protection at the network cable transition from the product outdoors to the network inside the building.

⚠ WARNING**Danger to life due to fire and deflagration**

In rare cases, an explosive gas mixture can be generated inside the product under fault conditions. In this state, switching operations can cause a fire and, in very rare cases, a deflagration inside the product. Death or lethal injuries due to the spread of a fire can result.

- In the event of a fault, do not perform any direct actions on the product.
- In the event of a fault, ensure that unauthorized persons have no access to the product.
- In case of failure, disconnect the PV module via an external disconnection device. If there is no disconnection device present, wait until no more DC power is applied to the inverter.
- In the event of a fault, disconnect the AC circuit breaker, or keep it disconnected in case it has already tripped, and secure it against reconnection.

⚠ WARNING**Risk of injury due to toxic substances, gases and dusts**

In rare cases, damages to electronic components can result in the formation of toxic substances, gases or dusts inside the product. Touching toxic substances and inhaling toxic gases and dusts can cause skin irritation, burns or poisoning, trouble breathing and nausea.

- Only perform work on the product (e.g., troubleshooting, repair work) when wearing personal protective equipment for handling of hazardous substances (e.g., safety gloves, eye and face protection, respiratory protection).
- Ensure that unauthorized persons have no access to the product.

⚠ WARNING**Danger to life due to electric shock from destruction of the measuring device due to overvoltage**

Overvoltage can damage a measuring device and result in voltage being present in the enclosure of the measuring device. Touching the live enclosure of the measuring device results in death or lethal injuries due to electric shock.

- Only use measuring devices with a measurement ranges designed for the maximum AC and DC voltage of the inverter.

⚠ CAUTION**Risk of burns due to hot enclosure parts**

The enclosure and the enclosure lid may get hot during operation. The DC load-break switch can not become hot.

- Do not touch hot surfaces.
- Wait until the inverter has cooled down before touching the enclosure or enclosure lid.

⚠ CAUTION**Risk of injury due to weight of product**

Injuries may result if the product is lifted incorrectly or dropped while being transported or mounted.

- Always have two persons mount and disassemble the product.
- Wear suitable personal protective equipment for all work on the product.
- Transport the product using the carrying handles or hoist. Take the weight of the product into account.
- Use all carrying handles provided during transport with carrying handles.
- Do not use the carrying handles as attachment points for hoist equipment (e.g. straps, ropes, chains). Insert eye bolts into threads provided on top of the product to attach the hoist system.

NOTICE**Damage to the enclosure seal in subfreezing conditions**

If you open the product when temperatures are below freezing, the enclosure seals can be damaged. Moisture can penetrate the product and damage it.

- Only open the product if the ambient temperature is not below .
- If the product must be opened in freezing conditions, make sure that the DC load-break switch is free of ice.

NOTICE**Damage to the product due to sand, dust and moisture ingress**

Sand, dust and moisture penetration can damage the product and impair its functionality.

- Only open the product if the humidity is within the thresholds and the environment is free of sand and dust.
- Close tightly all enclosure openings.

NOTICE**Damage to the inverter due to electrostatic discharge**

Touching electronic components can cause damage to or destroy the inverter through electrostatic discharge.

- Ground yourself before touching any component.

i The country data set must be set correctly.

If you select a country data set which is not valid for your country and purpose, it can cause a disturbance in the PV system and lead to problems with the grid operator. When selecting the country data set, you must always observe the locally applicable standards and directives as well as the properties of the PV system (e.g. PV system size, grid-connection point).

- If you are not sure which standards and directives are valid for your country or purpose, contact the grid operator.

i Communication disturbances in the local network

The IP address range 192.168.12.0 to 192.168.12.255 is reserved for internal communication and direct access between SMA products and cannot be used for system communication within the local network.

Communication problems might occur if this IP address range is used in the local network.

- Do not use the IP address range 192.168.12.0 to 192.168.12.255 in the local network.

3 Scope of delivery

Check the scope of delivery for completeness and any externally visible damage. Contact your distributor if the scope of delivery is incomplete or damaged.

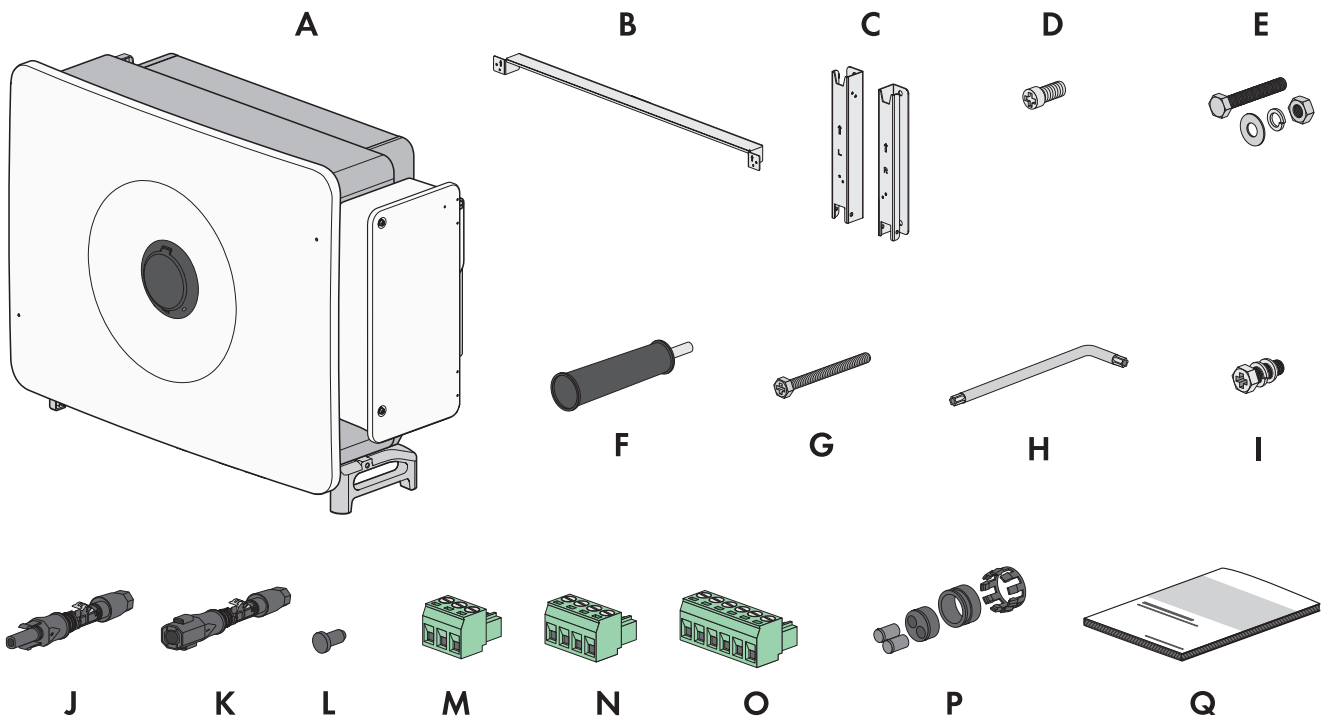

Position	Quantity	Designation
A	1	Inverter
B	1	Connecting rod for mounting bracket
C	1	Bracket part for mounting bracket
D	2	Cylindrical screw M4 x 10
E	4	M10x45 hexagon head bolt with 1 M10 washer, 1 M10 spring washer and one M10 hex nut
F	4	Carrying handle
G	2	Hexagon head bolt M6x65
H	1	Internal Allen key TX30
I	1	Hexagon head bolt M6x20, replacement bolt for the AC cable compartment
J	24	Positive DC connector
K	24	Negative DC connector
L	48	Sealing plug
M	1	3-pole terminal block, pre-assembled
N	2	4-pole terminal block, pre-assembled
O	1	6-pole terminal block, pre-assembled

Position	Quantity	Designation
P	2	Two-hole sealing block for communication terminal with inserts for cable diameters from 4.5 mm to 6 mm and 6 mm to 8 mm
Q	1	Documentation package consists of: <ul style="list-style-type: none">• Safety information booklet• Quick reference guide poster with illustrated instructions for initial installation and commissioning• Supplementary sheet with password label contains the following information:<ul style="list-style-type: none">- PIC (Product Identification Code) identification key for registering the system in Sunny Portal- RID (Registration Identifier) registration ID for registering the system in Sunny Portal- Wi-Fi password WPA2-PSK (WiFi Protected Access 2 - Preshared Key) for direct connection to the product via Wi-Fi

4 Additionally Required Materials and Equipment

Material	Quantity	Explanation
Profile rail (length: min. 1100 mm, depth: max. 60 mm, height: 50 mm to 80 mm)	2	Required exclusively if the product is intended to be mounted using a profile rail
Threaded ring (M12)	2	Only required if the product is to be transported with a lifting gear
Heavy-duty anchor (M10x95)	4	Only required if mounted without profile rails: For mounting the device on a wall
Ring terminal lugs (M12)	5	To attach to the AC connection cables
Ethanol cleaning agent	1	Used to clean terminal lugs
Protective grease	1	Only required if cable is made of aluminum: Used to apply to aluminum conductor
Network cable	1	To establish communication with the product
Field-assembly RJ45 connector.	2	Only required if self-assembly network cable is used
Aids	Quantity	Explanation
Means of transport (e.g., pallet truck)	1	Used to transport packed product to installation site
Lifting gear	1	Only required if the product is to be transported with a lifting gear
Utility knife	1	Used to unpack the product
Flat-blade screwdriver (4 mm)	1	For loosening the sealing screw on the attachment bars of the inverter
Phillips screwdriver (PH2)	1	For attaching the connecting rod at the bracket parts for the mounting bracket
Tape measure	1	For measuring the distances between bore holes for mounting
Marker pen	1	For marking the bore holes for mounting
Hammer drill with Ø 12 mm and Ø 14 mm drill bit	1	For drilling the bore holes for mounting
Spirit level	1	For aligning the mounting bracket
Rubber mallet	1	Only required if mounted without profile rails: For securing the expanding screws for mounting
Wrench (AF16)	1	Only required if mounted with profile rails: For attaching the mounting bracket
Socket wrench with 16 mm insert	1	Only required if mounted with profile rails: For attaching the mounting bracket

Aids	Quantity	Explanation
Phillips screwdriver (PH3)	1	For attaching and securing the product to the mounting bracket
Cable cutter	1	For trimming cables
Insulation stripping tool	1	For insulating the cable for the AC connection
Press tool	1	For attaching the ring terminal lugs to the cables of the AC connection
Hot-air blower	1	For attaching the heat-shrink tubings to the AC conductors
Socket wrench with deep sockets (AF18)	1	For releasing and fastening the conductors with ring terminal lugs in the AC cable compartment
Clean cloth	1	Used to clean terminal lugs
Brush	1	Only required if mounted with profile rails: For cleaning the aluminum conductors
Wrench (AF33)	1	For loosening and attaching the swivel nut of the communication connection
Voltage detector with a measurement range designed for the maximum AC and DC voltage of the inverter	1	For verifying that no voltage is present
Current clamp	1	For verifying that no current is present

5 Product overview

5.1 Product Description

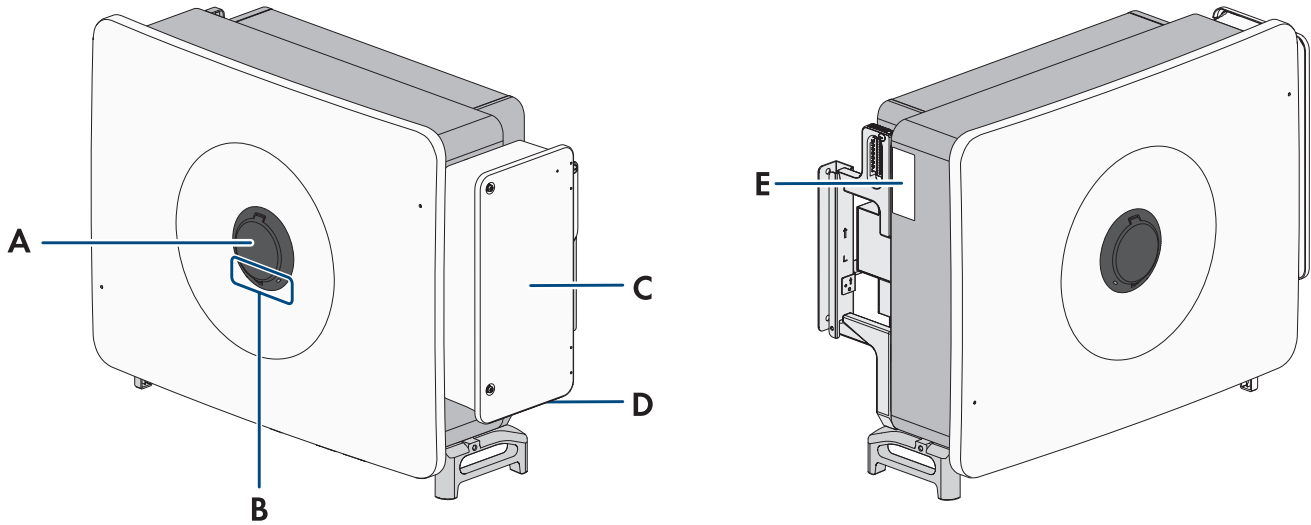



















Figure 1: Design of the product

Position	Designation
A	SMA Easy Lock enclosure lock
B	LEDs The LEDs indicate the operating state of the product.
C	Cable compartment cover
D	External ground connection (see Section 9.2.2, page 36)
E	Type label The type label clearly identifies the product. The type label must remain permanently attached to the product. You will find the following information on the type label: <ul style="list-style-type: none"> • Device type (Model) • Serial number (Serial No. or S/N) • Date of manufacture • Device specific characteristics

5.2 Symbols on the Product

Symbol	Explanation
	Beware of a danger zone This symbol indicates that the product must be additionally grounded if additional grounding or equipotential bonding is required at the installation site.
	Beware of electrical voltage The product operates at high voltages.

Symbol	Explanation
	Beware of hot surface The product can get hot during operation.
	Danger to life due to high voltages in the inverter; observe a waiting time of minutes. High voltages that can cause lethal electric shocks are present in the live components of the inverter. Before carrying out any work on the inverter, always de-energize the inverter as described in this document and secure it against reconnection.
	Observe the documentation Observe all documentations supplied with the product.
	Operation LED Indicates whether the product is in operation.
	Error Together with the red LED, this symbol indicates an error. Observe the documentation.
	Data transmission Together with the blue LED, this symbol indicates the status of the network connection.
	Grounding conductor This symbol indicates the position for connecting a grounding conductor.
	Three-phase alternating current with neutral conductor
	Direct current
	The product has no galvanic isolation.
	WEEE designation Do not dispose of the product together with the household waste but in accordance with the disposal regulations for electronic waste applicable at the installation site.
	The product is suitable for outdoor installation.
	CE marking The product complies with the requirements of the applicable EU directives.
	RoHS labeling The product complies with the requirements of the applicable EU directives.
	RCM (Regulatory Compliance Mark) The product complies with the requirements of the applicable Australian standards.

5.3 Interfaces and Functions

5.3.1 User Interface

The product is equipped as standard with an integrated webserver, which provides a user interface for configuring and monitoring the product.

Once the connection has been established to the smart device, use a device (e.g. smartphone, tablet or laptop) to connect to the product's user interface using a web browser.

5.3.2 Arc-Fault Circuit Interrupter (AFCI)

The arc-fault circuit interrupter is deactivated by default and can be activated on the user interface.

The inverter is equipped with an arc fault circuit interrupter (AFCI). The inverter supports the Arc Fault Protection Equipment (AFPE) for arc fault detection and interruption. The AFPE protection covers the PV modules and DC cables of the PV system connected to the DC input terminals of the inverter. A detected electric arc causes a brief interruption of the feed-in operation.

An event message is entered on the user interface when an electric arc is detected. After a waiting period of 10 minutes, the inverter starts automatically and checks whether the electric arc is still present. If the electric arc is still present, the inverter disconnects from the utility grid again and the process is repeated. After 5 electric arc detections per day (24h), the feed-in operation of the inverter must be activated via direct or remote access via the user interface of the inverter. The configuration settings can be found in the corresponding section under Operation (see Section 11.17, page 70).

The AFPE detection has 24 channels and one input port per channel.

5.3.3 Modbus

The inverter is equipped with a Modbus interface. The Modbus interface is deactivated by default and must be configured as needed.

The Modbus interface of the supported SMA products is designed for industrial use – via SCADA systems, for example – and has the following tasks:

- Remote query of measured values
- Remote setting of operating parameters
- Setpoint specifications for system control

5.3.4 Grid Management Services

The product is equipped with service functions for grid management.

Depending on the requirements of the grid operator, you can activate and configure the functions (e.g. active power limitation) via operating parameters.

5.3.5 Zero export

Some grid operators permit connection of PV systems only on condition that no active power is fed into the utility grid. The PV energy is therefore consumed exclusively at the place where it is generated.

This product supports the limitation of the zero export in conjunction with a communication product (e.g., SMA Data Manager M)

5.3.6 Fast stop function

The fast stop function is a digital input on the inverter via which the inverter can be disconnected from the utility grid. It can be triggered by means of an external potential-free contact (break contact).

The inverter is equipped with 2 fast-stop inputs. Due to its response time of < 100 ms, the first input **FS1** can be connected with an external monitoring unit (e.g. for grid and PV system protection), for example. The second input **FS2** can be used for additional disconnection via an external switch. The reaction time there is < 1 s.

The digital input can, for example, be used to implement the grid and PV system protection as required by VDE-AR-N-4105. The inverter is suitable for grid disconnection due to its redundant and integrated interface switch. Here, the disconnection units integrated in the inverter can replace an external interface switch. An external, certified monitoring unit with an integrated potential-free PV system protection relay and an alarm contact configured as a break contact must be connected to the inverter's fast-stop input.

The fast stop function is deactivated by default and must be activated in the inverter.

5.3.7 SMA ShadeFix

The inverter is equipped with the shade management system SMA ShadeFix. SMA ShadeFix uses an intelligent MPP tracking system to determine the operating point with the highest output during shading conditions. With SMA ShadeFix, inverters use the best possible energy supply from the PV modules at all times to increase yields in shaded systems.

SMA ShadeFix is enabled by default.

The time interval of SMA ShadeFix is usually 6 minutes. This means that the inverter determines the optimum operating point every 6 minutes. Depending on the PV system or shading situation, it may be useful to adjust the time interval.

5.3.8 SMA Smart Connected

SMA Smart Connected is the free monitoring of the product via the SMA Sunny Portal. Thanks to SMA Smart Connected, the operator and qualified person will be informed automatically and proactively about product events that occur.

SMA Smart Connected is activated during registration in Sunny Portal. In order to use SMA Smart Connected, it is necessary that the product is permanently connected to Sunny Portal and the data of the operator and qualified person is stored in Sunny Portal and up-to-date.

5.3.9 SMA Speedwire

The product is equipped with SMA Speedwire as standard. SMA Speedwire is a type of communication based on the Ethernet standard. SMA Speedwire is designed for a data transfer rate of 100 Mbps and enables optimum communication between Speedwire devices within systems.

The products supports the encrypted system communication with SMA Speedwire Encrypted Communication. In order to be able to use the Speedwire encryption in the system, all Speedwire devices, except for the energy meter, must support the function SMA Speedwire Encrypted Communication.

5.3.10 SMA Webconnect

The inverter is equipped with a Webconnect function as standard. The Webconnect function enables direct data transmission between the inverters of SMA Internet portals, without any additional communication device and for a maximum of 4 inverters per visualized system. If there is an existing Wi-Fi or Ethernet connection, you can directly access your visualized system via the web browser on your smart device (e.g. smartphone, tablet or laptop). If the system is subject to a control requirement, a data logger, such as the SMA Data Manager M, must be installed together with an energy meter at the point of interconnection.

5.3.11 Wi-Fi connection to SMA 360° app and SMA Energy app

There is a QR code on the product by default. By scanning the QR Code attached to the product via the SMA 360° app or SMA Energy app, access to the product is established via Wi-Fi and the connection to the user interface is made automatically.

Also see:

- [Direct connection via Wi-Fi ⇒ page 59](#)

5.3.12 Wi-Fi

The product is equipped with a Wi-Fi interface as standard. The inverter is delivered with the WLAN interface activated as standard. If you do not want to use WLAN, you can deactivate the WLAN interface.

The Wi-Fi interface can be used for configuration and commissioning. For control applications, such as those involving the Data Manager M, the network connection should be established via the Ethernet ports.

5.4 LED Signals

The LEDs indicate the operating state of the product.

LED signal	Explanation
Green LED and red LED flash simultaneously (2 s on and 2 s off)	No country data set set Operation of the product is stopped because no country data set is set. Once the configuration has been completed (for instance using the installation assistant or via a communication product), the product will start operation automatically.
The green LED is flashing (2 s on and 2 s off)	Waiting for feed-in conditions The conditions for feed-in operation are not yet met. As soon as the conditions are met, the inverter will start feed-in operation.
The green LED is glowing	Feed-in operation The inverter is feeding in.
The green LED is off	There is no voltage at the PV inputs of the inverter.
The red LED is glowing	Event occurred If an event occurs, a distinct event message and the corresponding event number will be displayed in addition on the product user interface or in the communication product (e.g. Sunny Home Manager).
Red LED is flashing (0.25 s on, 0.25 s off, 0.25 s on, 1.25 s off)	Warning Communication with a superordinate plant controller has failed. The inverter continues to operate with restricted function (e.g. with set fallback level). In addition, a distinct event message and the corresponding event number will be displayed on the product user interface or in the communication product (e.g. Sunny Home Manager).
The blue LED flashes slowly for approx. 1 minute	Communication connection is being established The product is establishing a connection to a local network or is establishing a direct connection to a smart device via Ethernet (e.g. smartphone, tablet or laptop).
The blue LED is flashing fast (0.25 s on and 0.25 s off)	A communication product requests identification of the inverter.
The blue LED is glowing	There is an active connection with a local network (LAN/Wi-Fi) or there is a direct connection (Ethernet/WPS function) with a smart end device (e.g. smartphone, tablet or laptop).
Blue LED is off	There is no active connection.
All 3 LEDs are on	Inverter update or booting procedure

5.5 System overview

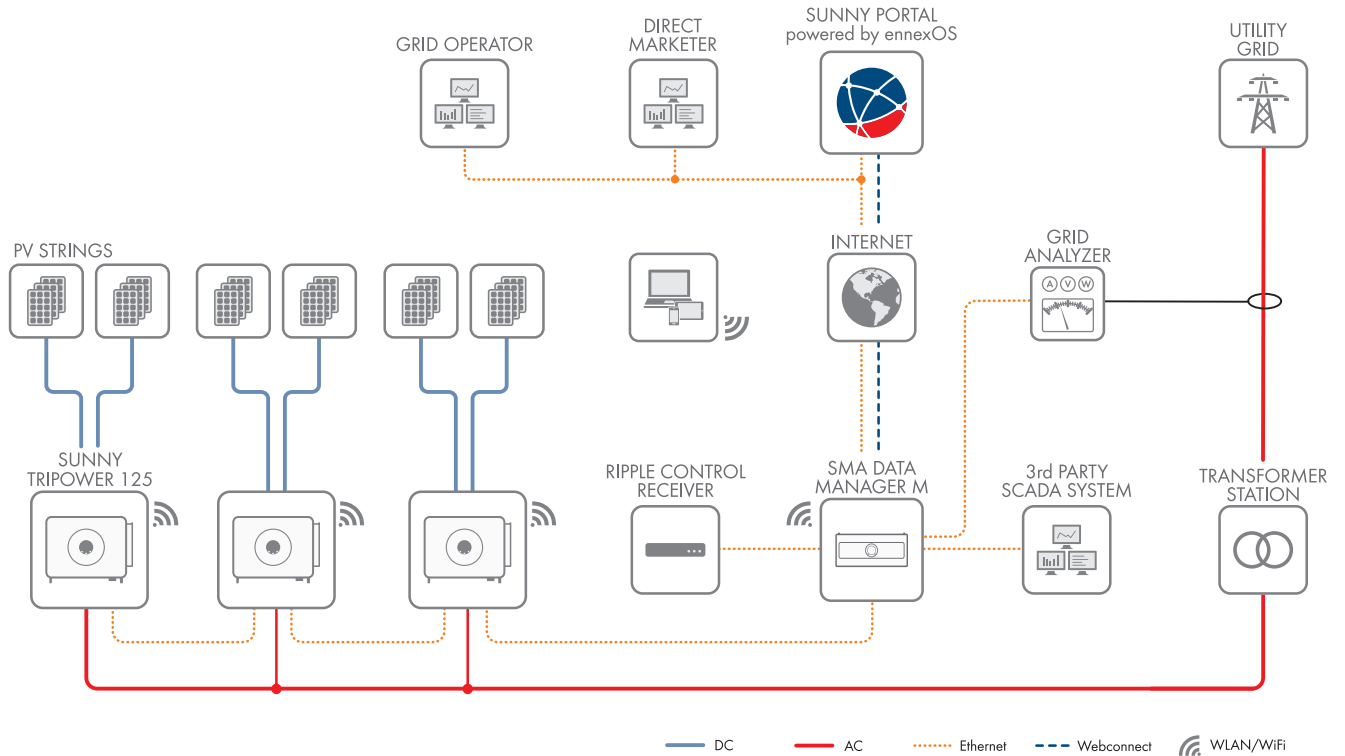

Figure 2: System design

5.6 Block circuit diagram of the inverter

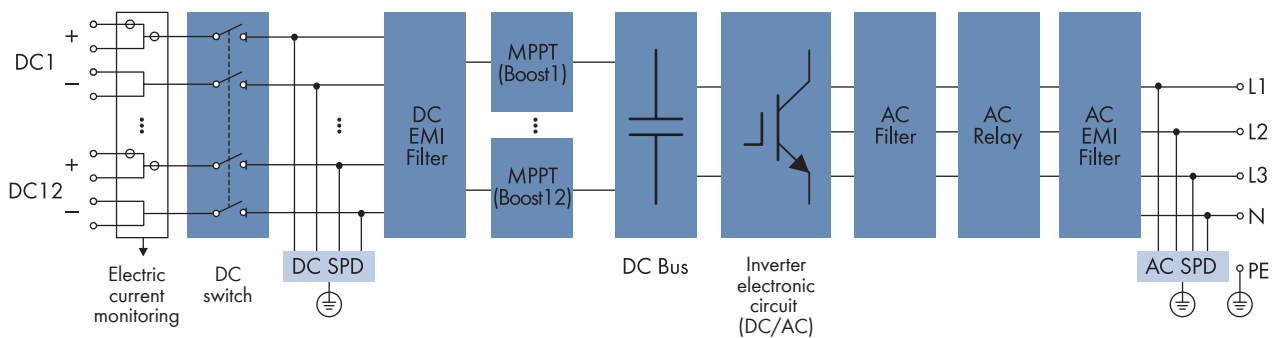

Figure 3: Block circuit diagram of the inverter

6 Mounting

6.1 Requirements for Mounting

6.1.1 Requirements for the Mounting Location

⚠ QUALIFIED PERSON

⚠ WARNING

Danger to life due to fire and deflagration

In rare cases, an explosive gas mixture can be generated inside the product under fault conditions. In this state, switching operations can cause a fire and, in very rare cases, a deflagration inside the product. Death or lethal injuries due to the spread of a fire can result.

- In the event of a fault, do not perform any direct actions on the product.
- In the event of a fault, ensure that unauthorized persons have no access to the product.
- In case of failure, disconnect the PV module via an external disconnection device. If there is no disconnection device present, wait until no more DC power is applied to the inverter.
- In the event of a fault, disconnect the AC circuit breaker, or keep it disconnected in case it has already tripped, and secure it against reconnection.

- Mounting the inverter in living areas is not permitted.
- Specialists must have exclusive access to the mounting location.
- A solid support surface must be available (e.g., concrete or masonry, free-standing constructions).
- The mounting location must be suitable for the weight and dimensions of the product.
- The mounting location must not be exposed to direct solar irradiation. If the product is exposed to direct solar irradiation, the exterior plastic parts might age prematurely and overheating might occur. When becoming too hot, the product reduces its power output to avoid overheating.
- The DC load-break switch of the product must always be freely accessible.
- All ambient conditions must be met.
- Installation in areas with aggressive ambient conditions such as chemically active substances or gases (e.g. ammonia or chlorine) is not permitted. Please refer to the corrosivity categories in the products' technical data. Additional information is available under the following links: [Manufacturer's Declaration "Coastal Installation of SMA Products"](#) and [Manufacturer's Declaration "Installation of Sunny Tripower inverters in locations with a moderate ammonia concentration"](#) and at www.SMA-Solar.com.

6.1.2 Permitted and prohibited mounting positions

⚠ QUALIFIED PERSON

- The product may only be mounted in a permitted position. This will ensure that no moisture can penetrate the product.
- The product should be mounted such that the LED signals can be read off without difficulty.

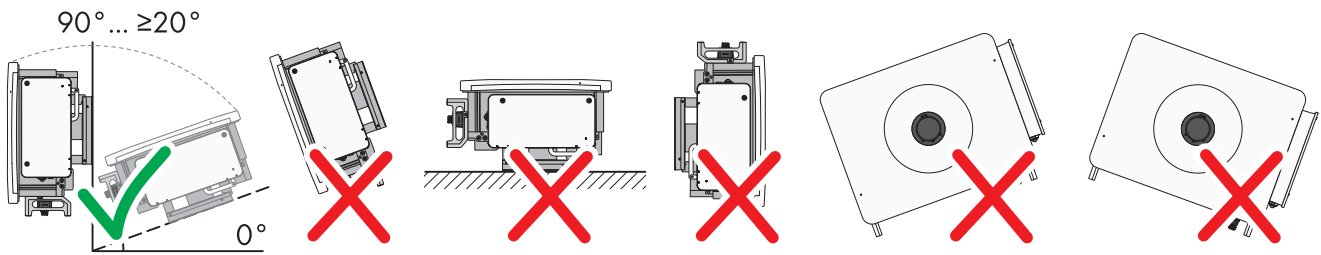
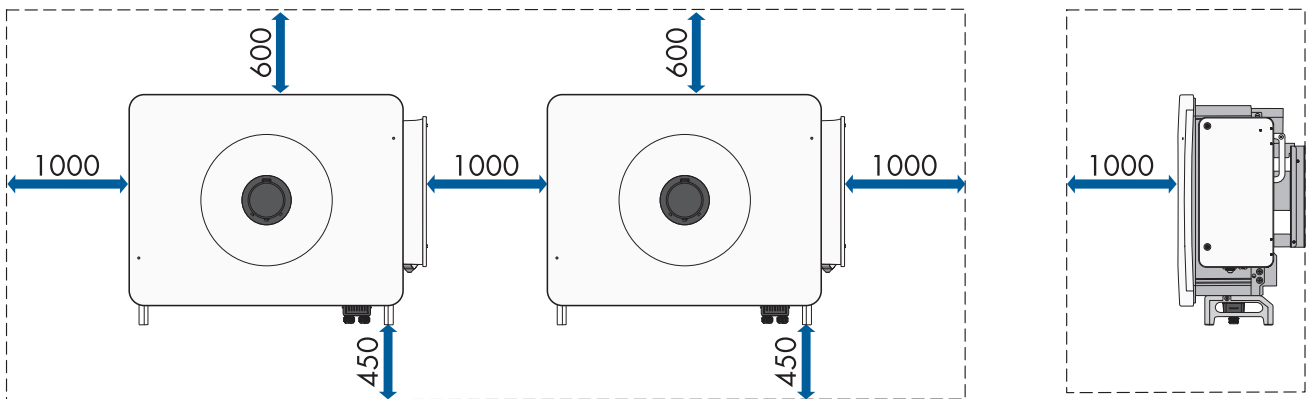

Figure 4: Permitted and prohibited mounting positions

6.1.3 Recommended clearances

⚠ QUALIFIED PERSON

- Recommended distances to walls, other devices and objects should be maintained.
- If multiple products are mounted in areas with high ambient temperatures, increase the clearances between the products and ensure sufficient fresh-air supply.



6.2 Mounting to Profile Rails

6.2.1 Requirements for mounting on profile rails

⚠ QUALIFIED PERSON

- At least 2 profile rails must be available for mounting.
- The support surface of the frame to which the profile rails are attached should be firm and level (e.g. concrete). Non-fulfillment of these criteria may restrict servicing.
- The profile rails must be designed for the load and orientation of the inverters in the PV system. The profile rails might need to be reinforced.
- The spacing of the profile rails must be designed for the spacing of the holes in the bracket parts for the mounting bracket.
- The profile rails must be designed for the clamping range of the mounting bracket.

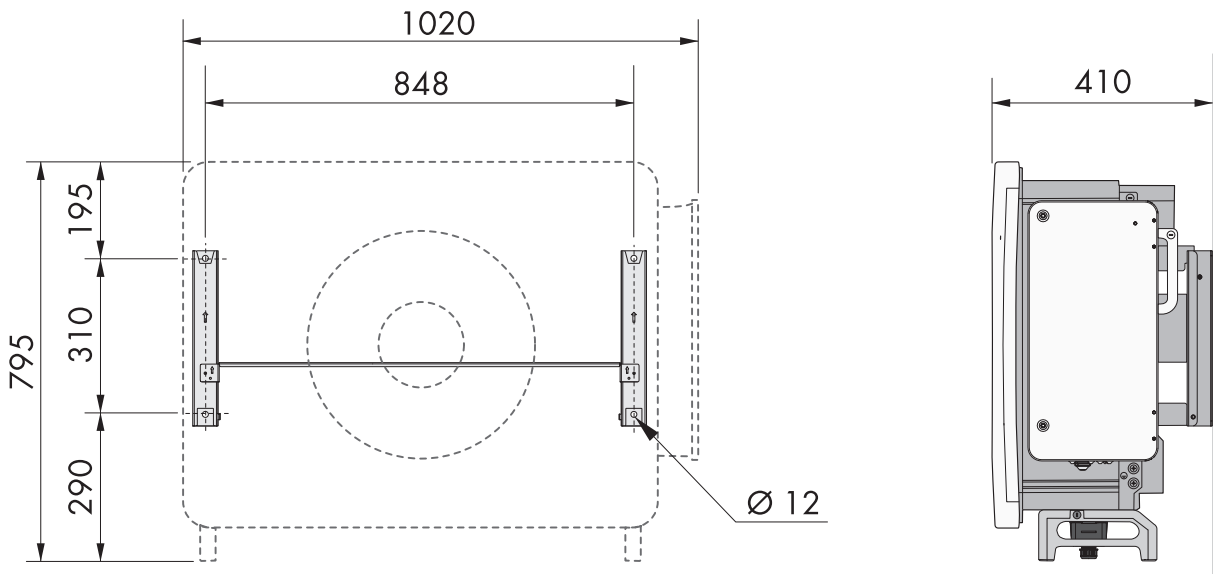

Figure 5: Dimensions of the mounting bracket (dimensions in mm)

6.2.2 Mounting the Product to Profile Rails

⚠ QUALIFIED PERSON

⚠ CAUTION

Risk of injury due to weight of product

Injuries may result if the product is lifted incorrectly or dropped while being transported or mounted.

- Always have two persons mount and disassemble the product.
- Wear suitable personal protective equipment for all work on the product.
- Transport the product using the carrying handles or hoist. Take the weight of the product into account.
- Use all carrying handles provided during transport with carrying handles.
- Do not use the carrying handles as attachment points for hoist equipment (e.g. straps, ropes, chains). Insert eye bolts into threads provided on top of the product to attach the hoist system.

Procedure:

1. Screw the bracket parts to the ends of the connecting rod (PH2, torque: 1.5 Nm) using the cheese head screws (M4x10) to mount the mounting bracket.

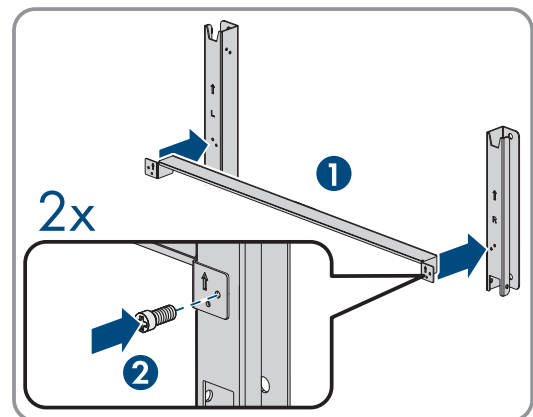

2. Align the mounting bracket using a spirit level and mark the drilling positions on the profile rails.
3. Drill the bore holes (Ø 12 mm) at the marked areas.

4. Attach the mounting bracket to the profile rails (AF16, tightening torque: 35 Nm) using 4 hexagon head screws (M10x45). In this process, use 1 washer, 1 spring washer and 1 hex nut each.

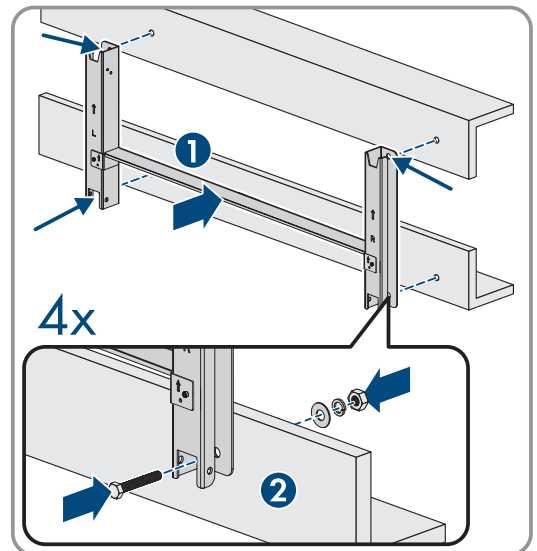

5. Remove the sealing screws on the sides of the inverter using a flat-blade screwdriver (4 mm).

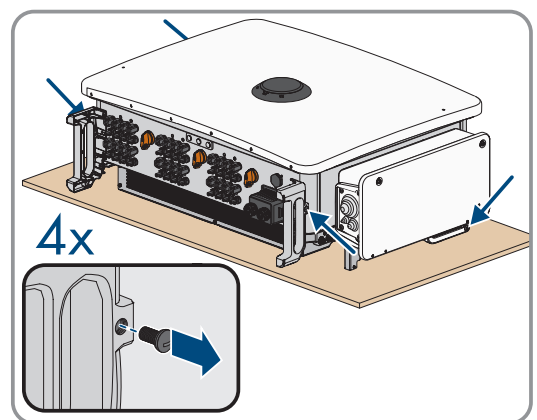

6. If the inverter is to be hooked into the mounting bracket using a lifting gear, screw the eye bolts into the 2 upper threaded holes on the right-hand and left-hand side of the inverter and attach the lifting gear to them. The lifting gear must be suitable to take the weight of the inverter.

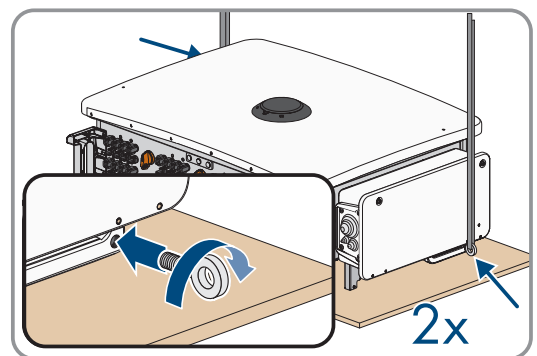

7. If the inverter is to be hooked into the mounting bracket without using a lifting gear, screw the carrying handles as far as they will go into the threaded holes on the right-hand and left-hand side until they lie flush with the enclosure. When doing so, ensure that the carrying handles are screwed into the threaded holes so that they are perfectly straight. If the carrying handles are not screwed in straight, this can make it more difficult or even impossible to unscrew them later on and can damage the threaded holes to the extent that carrying handles can no longer be screwed into them.

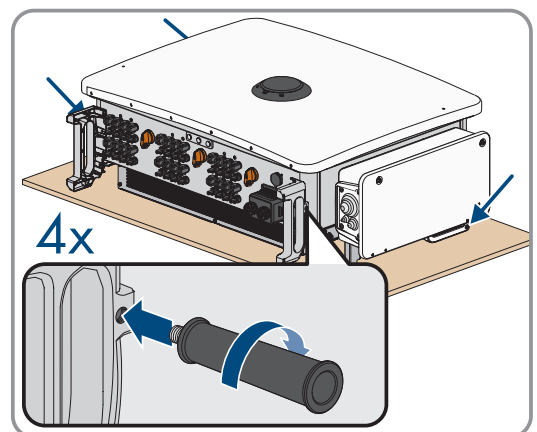

8. Hook the inverter into the mounting bracket.

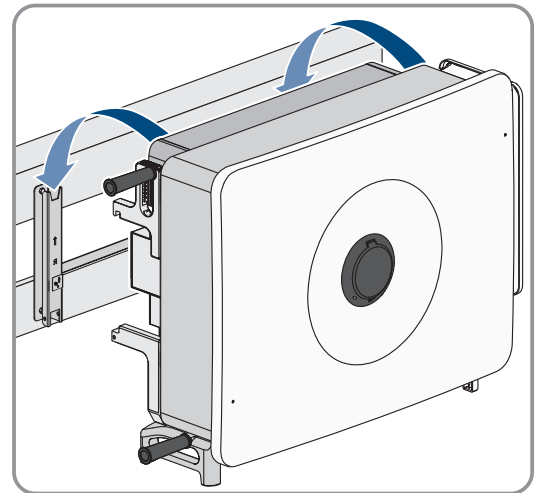

9. Remove all 4 carrying handles from the threaded holes or remove the eye bolts of the lifting gear and again screw in the sealing screws using a flat-blade screwdriver (4 mm, tightening torque: 2 Nm).

10. Use the hexagon head screws (M6x65) to attach the inverter to the mounting bracket (PH3, tightening torque: 4.5 Nm).

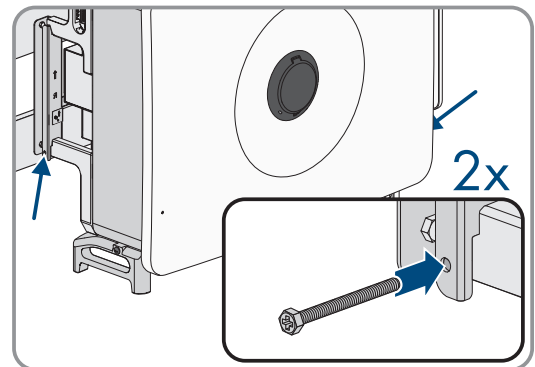

11. If the inverter was hooked into the mounting bracket without lifting gear, remove the carrying handles from the threaded holes on the right and left side.

6.3 Mounting the Product on a Wall

⚠ QUALIFIED PERSON

⚠ CAUTION

Risk of injury due to weight of product

Injuries may result if the product is lifted incorrectly or dropped while being transported or mounted.

- Always have two persons mount and disassemble the product.
- Wear suitable personal protective equipment for all work on the product.
- Transport the product using the carrying handles or hoist. Take the weight of the product into account.
- Use all carrying handles provided during transport with carrying handles.
- Do not use the carrying handles as attachment points for hoist equipment (e.g. straps, ropes, chains). Insert eye bolts into threads provided on top of the product to attach the hoist system.

Additionally required material (not included in the scope of delivery):

- 4 heavy-duty anchors

Procedure:

1. Screw the bracket parts to the ends of the connecting rod (PH2, tightening torque: 1.5 Nm) using the cheese head screws (M4x10) to mount the mounting bracket.

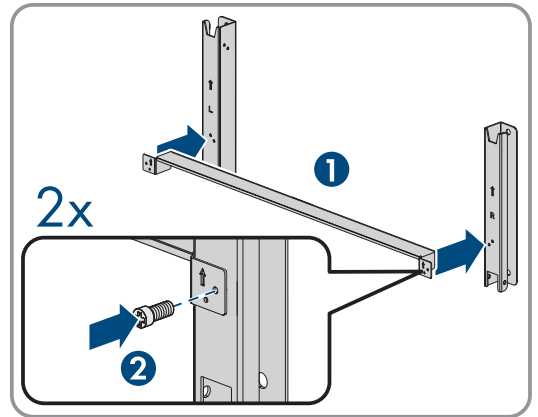

2. Align the mounting bracket using a spirit level and mark the drilling positions.
3. Drill the bore holes (\varnothing 12 mm) at the marked areas.
4. Attach the mounting bracket to the wall using the heavy-duty anchors.

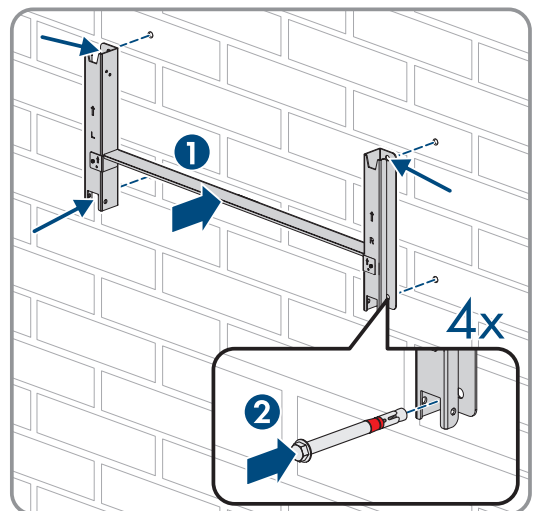

5. Remove the sealing screws on the sides of the inverter using a flat-blade screwdriver (4 mm).

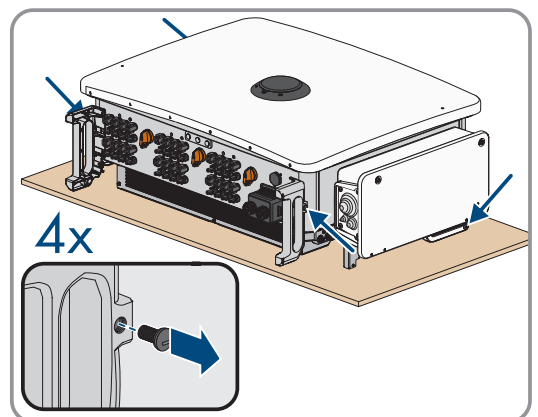

6. If the inverter is to be hooked into the mounting bracket using lifting gear, screw the eye bolts into the 2 upper threaded holes on the right-hand and left-hand side of the inverter and attach the lifting gear to them. The lifting gear and the eye bolts must be suitable to take the weight of the inverter.

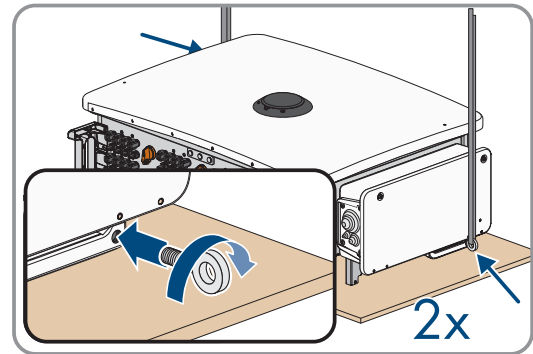

7. If the inverter is to be hooked into the mounting bracket without using a lifting gear, screw the carrying handles as far as they will go into the threaded holes on the right-hand and left-hand side until they lie flush with the enclosure. When doing so, ensure that the carrying handles are screwed into the threaded holes so that they are perfectly straight. If the carrying handles are not screwed in straight, this can make it more difficult or even impossible to unscrew them later on and can damage the threaded holes to the extent that carrying handles can no longer be screwed into them.

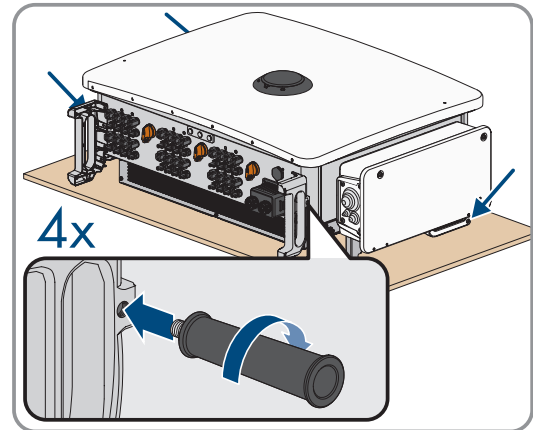

8. Hook the inverter into the mounting bracket.

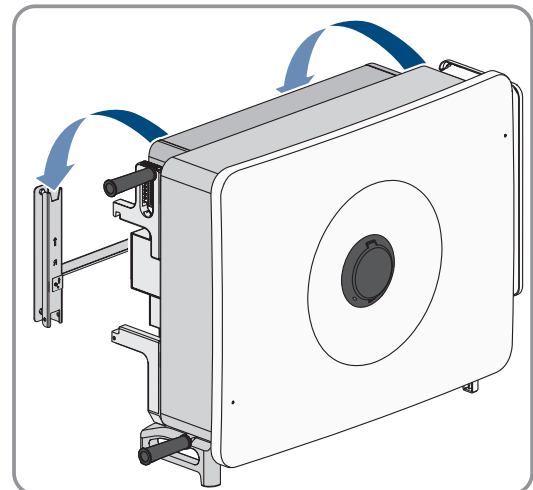

9. Remove all 4 carrying handles from the threaded holes or remove the eye bolts of the lifting gear and once again screw in the sealing screws (flat-blade screwdriver 4 mm, tightening torque: 2 Nm).
10. Use the hexagon head screws (M6x65) to attach the inverter to the mounting bracket (PH3, tightening torque: 4.5 Nm).

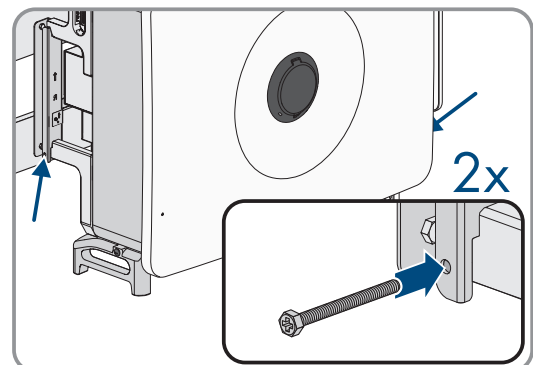

11. If the inverter was hooked into the mounting bracket without lifting gear, remove the carrying handles from the threaded holes on the right and left side.

7 Opening the Cable Compartment

⚠ QUALIFIED PERSON

For some of the actions described in this document, the cable compartment must be opened.

Procedure:

1. Disconnect the inverter from voltage sources and secure it against being switched on again (see Section 12, page 79).
2. Loosen the two screws (M6x20) on the cable compartment cover using the enclosed internal Allen key and open the cable compartment.

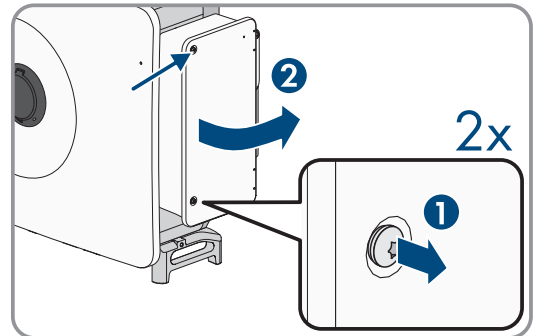

3. Lift the limiting lever on the inside of the cover on the right and remove from the thread.

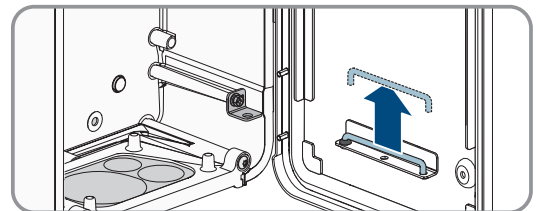

4. Engage the end of the limiting lever in the cable compartment with the thread.

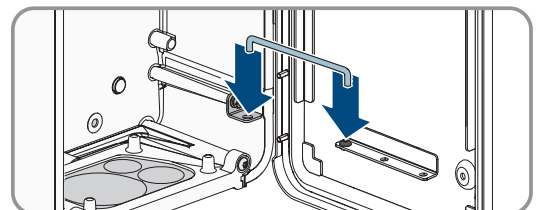

The cable compartment cover has been secured and remains open.

8 Installing Optional AC Sealing Plate

⚠ QUALIFIED PERSON

For the product, an optional AC sealing plate can be used for the connection with 5 insulated conductors. The optional AC sealing plate can be ordered as a set consisting of 8 individual AC sealing plates in the SMA online shop (www.sma-onlineshop.com) by indicating the material number 211813-00.01.

Additional AC cable requirements:

- \varnothing 14 mm² to 32 mm² per insulated conductor

Procedure:

1. Open the AC cable compartment (see Section 7, page 31).
2. Loosen the 2 screws (TX30) in the lower section of the cable compartment.

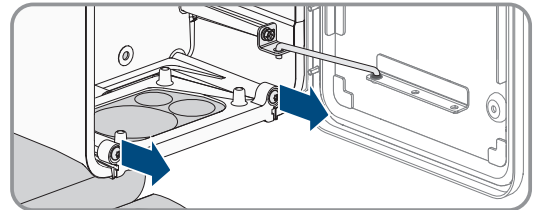

3. Pull the AC seal plate with cassette out of the guide.

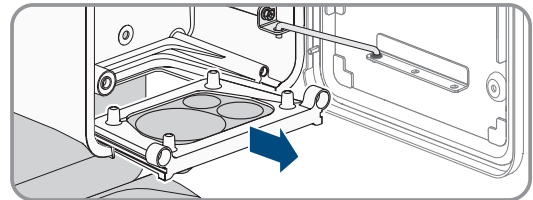

4. Loosen the 4 screws of the AC sealing plate attached to the inverter at delivery (TX30) and remove the AC sealing plate.

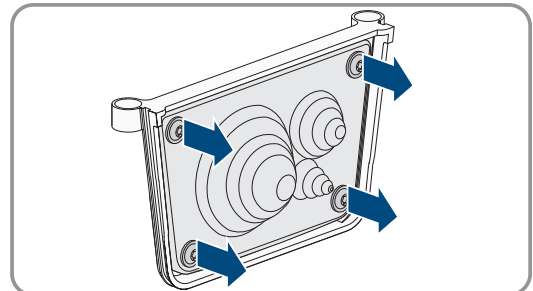

5. Ensure that the AC device opening is free of contamination.
6. Ensure that the seal of the optional AC sealing plate is undamaged and free of contamination.
7. Attach the optional AC sealing plate to the cassette using the 4 screws included in delivery (TX30, tightening torque: 4.3 Nm).

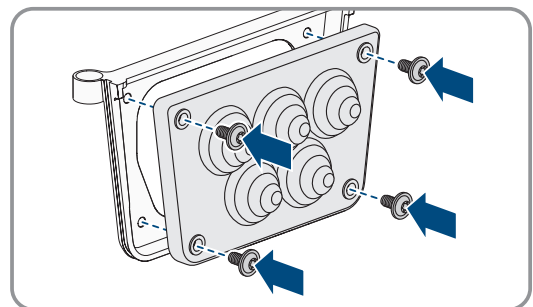

8. Slide the cassette into the inverter and secure it to the cable compartment with the 2 screws (TX30, tightening torque: 4.3 Nm).

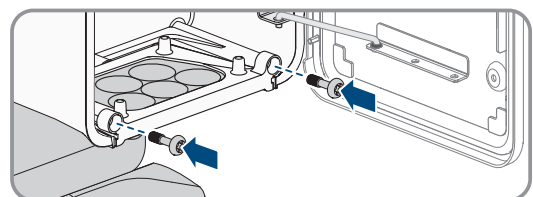

9 Electrical Connection

9.1 Requirements for the electrical connection

9.1.1 Permitted grid configurations

The inverter approved for operation in the following utility grids:

- TN-C
- TN-S
- TN-C-S
- TT (if $UN_{PE} < 20\text{ V}$)

Operation of the inverter in IT or Delta IT grids is not permitted. An N conductor is always required.

TN-C system

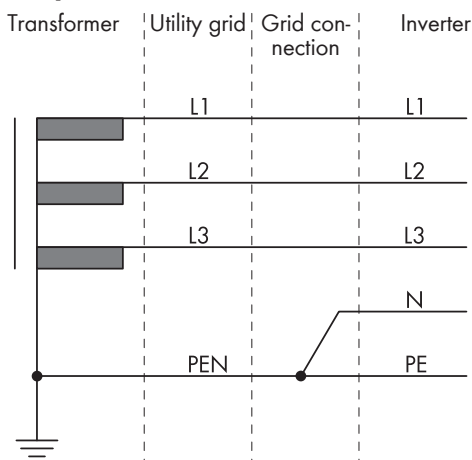

TN-S system

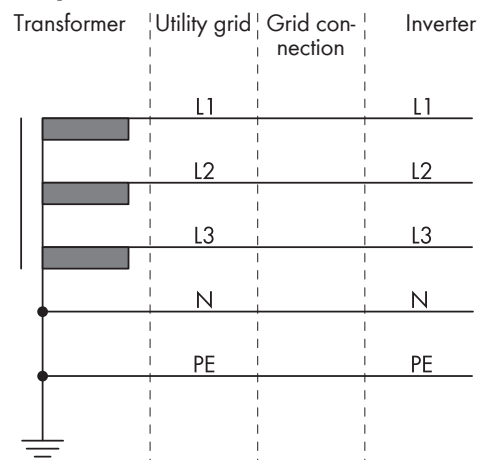

TN-C-S grid configuration

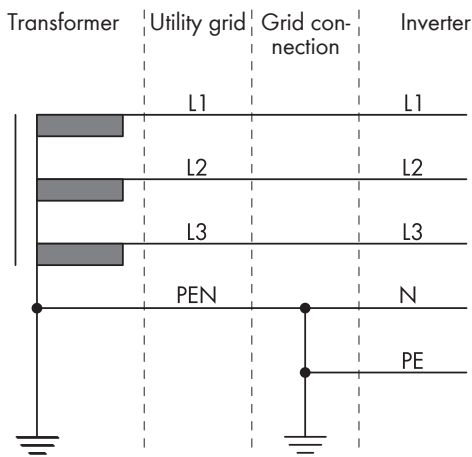

TT system

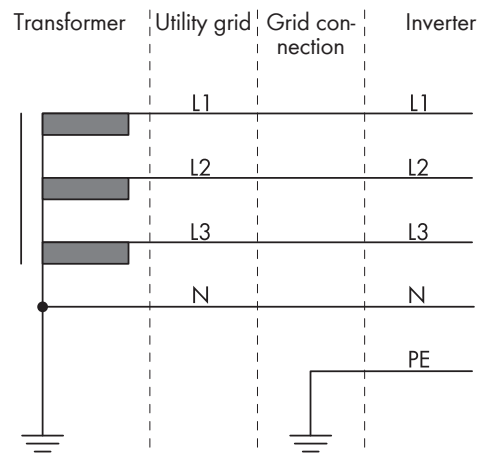

Figure 6: Overview of approved grid configurations

9.1.2 Residual-current monitoring unit

The inverter does not require an external residual-current device when operating. If local regulations require the use of a residual-current device, the following must be observed:

- The inverter is compatible with type B residual-current devices with a rated residual current of 1250 mA or higher (see Technical Information in www.SMA-Solar.com for information on how to select a residual-current device). Each inverter in the system must be connected to the utility grid via a separate residual-current device.

- When using residual-current devices with a lower rated residual current, there is a risk of false tripping of the residual-current device, depending on the system design.

9.1.3 Load-break switch and cable protection

NOTICE

Damage to the inverter due to the use of screw-type fuses as load-break switches

Screw-type fuses (e.g. DIAZED fuse or NEOZED fuse) are not load-break switches.

- Do not use screw-type fuses as load-break switches.
- Use a load-break switch or circuit breaker as a load disconnection unit (for information and design examples, see the Technical Information at www.SMA-Solar.com).

- In PV systems with multiple inverters, protect each inverter with a separate three-phase circuit breaker. Make sure to observe the maximum permissible fuse protection (see Section 17, page 111). This will prevent residual voltage from being present at the corresponding cable after disconnection.
- Loads installed between the inverter and the circuit breaker must be fused separately.

9.1.4 Equipotential Bonding

If components are used in the PV system that require equipotential bonding (e.g., mounting racks, module frames), these must be connected to a central equipotential panel provided for this purpose.

Observe the installation guidelines and regulations applicable in your country. The enclosure of the inverter is not suitable as equipotential bonding. Incorrect implementation of equipotential bonding can lead to an inverter defect that is not covered under warranty.

9.1.5 AC cable requirements

- Conductor type: copper wire or aluminum wire
- External diameter: 30 mm to 60 mm
- Conductor cross-section of grounding conductor:
 - For copper wire: 35 mm² to 150 mm²
 - For aluminum wire: 70 mm² to 240 mm²
- Conductor cross-section of line conductor and neutral conductor:
 - For copper wire: 70 mm² to 150 mm²
 - For aluminum wire: 120 mm² to 240 mm²
- Insulation stripping length: 18 mm to 20 mm
- Sheath stripping length: 120 mm to 150 mm
- The cable and conductor cross-sections must always be dimensioned according to the local and national directives and within the range specified by the manufacturer (I).¹ If the manufacturer (I) requires a higher conductor cross-section than the standard, the range of the manufacturer must be observed. Examples of factors influencing cable dimensioning are: nominal AC current, type of cable, routing method, cable bundling, ambient temperature and maximum desired line losses (for calculation of line losses, see the design software "Sunny Design" from software version 2.0 at www.SMA-Solar.com).

9.1.6 Network cable requirements

The cable length and quality affect the quality of the signal. Observe the following cable requirements:

- Cable type: 100BaseTx
- Cable category: minimum CAT5e
- Shielding: SF/UTP, S/UTP, SF/FTP or S/FTP
- Number of insulated conductor pairs and insulated conductor cross-section: at least

- Maximum cable length between two nodes when using patch cables:
- Maximum cable length between two nodes when using installation cables:
- UV-resistant if installed outdoors.

9.1.7 DC cable requirements

- Outer diameter: 5.5 mm to 8 mm
- Conductor cross-section: 2.5 mm² to 6 mm²
- Qty single wires: minimum 7
- Nominal voltage: minimum 1100 V
- Using bootlace ferrules is not allowed.

9.1.8 Signal cable requirements

The cable length and quality affect the quality of the signal. Observe the following cable requirements:

- Conductor cross-section: from 0.2 mm² to 1.5 mm²
- External outer diameter: max. 8 mm
- Maximum cable length: 200 m
- Insulation stripping length: 6 mm
- Sheath stripping length: 150 mm
- UV-resistant for outdoor use
- The cable type and cable-laying method must be appropriate for the application and location.

9.2 Overview of the Connection Area

9.2.1 View from Below

⚠ QUALIFIED PERSON

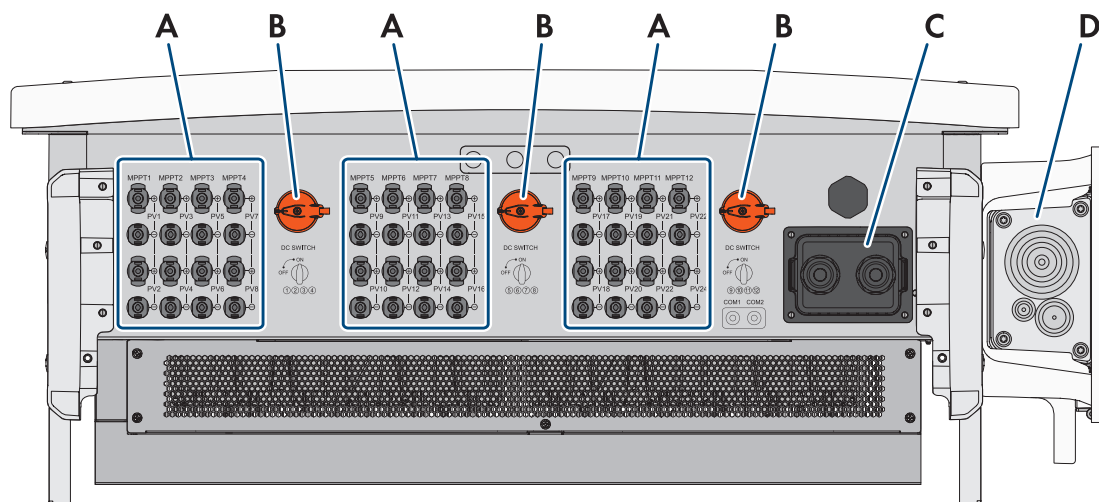

Figure 7: Enclosure openings at the bottom of the inverter

Position	Designation
A	Positive and negative connectors for DC connection
B	DC load-break switch

Position	Designation
C	Cable gland for connecting the communication
D	Sealing plate for the AC connection

9.2.2 Interior View

⚠ QUALIFIED PERSON

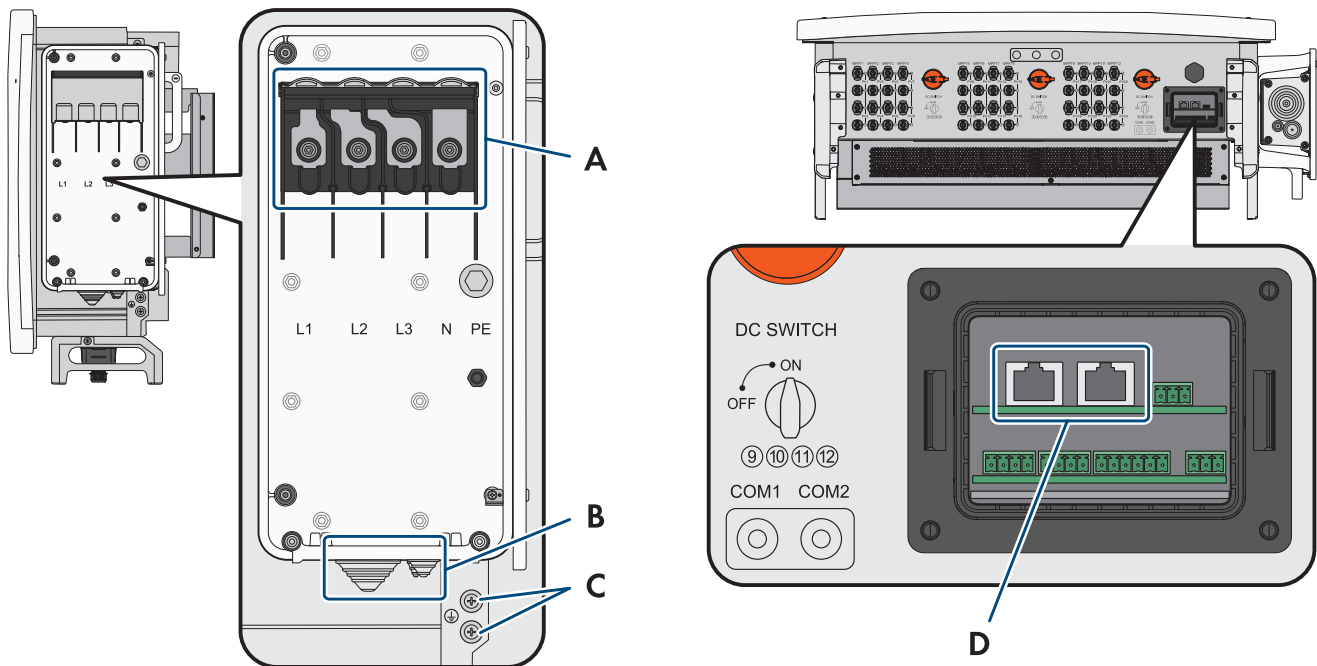

Figure 8: Connection area inside the inverter

Position	Designation
A	AC connection area
B	Sealing plate for the AC connection
C	Terminal for external grounding
D	Connection for Ethernet communication

9.2.3 Overview of the COM assembly connections

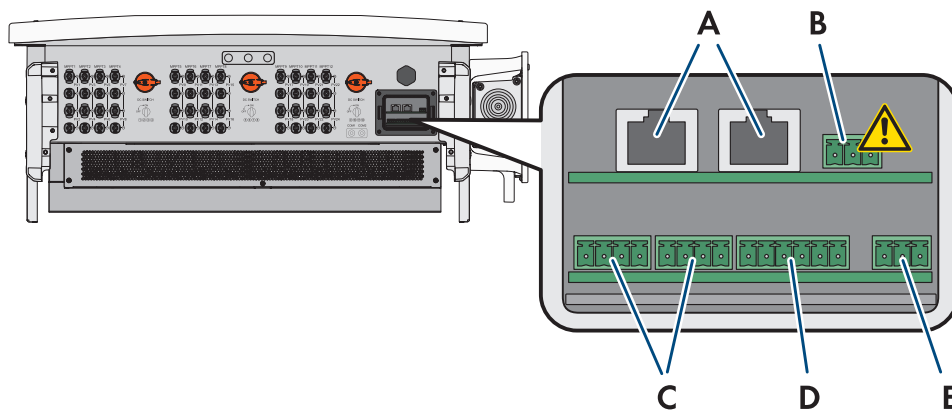

Figure 9: Digital inputs on the COM assembly

Position	Designation
A	Ethernet connections
B	Not allowed to be connected
C	Connections for digital fast-stop inputs
D	Terminal for digital inputs for curtailment
E	Connection for the multifunction relay

9.3 Electrical connection procedure

⚠ QUALIFIED PERSON

This section describes the procedure for the electrical connection of the product. It provides an overview of the steps, which must be performed in the prescribed sequence.

Procedure	See
1. Ensure that the requirements for the electrical connection are fulfilled.	Section 9.1, page 33
2. Connect the inverter to the utility grid.	Section 9.4, page 37
3. Connect protective grounding.	Section 9.5, page 40
4. Connect the network cables.	Section 9.6, page 40
5. Connect the PV modules.	Section 9.10.3, page 53

9.4 Connecting the Inverter to the Utility Grid

⚠ QUALIFIED PERSON

Required material (not included in the scope of delivery):

- Protective grease (only for conductors made of aluminum)
- 4 heat-shrink tubings
- 4 ring terminal lugs with hole diameter 12 mm (for conductors made of aluminum bimetal terminal lugs made of aluminum and copper)

Procedure:

1. Disconnect the AC miniature circuit breaker from all 3 line conductors and secure against reconnection.
2. Make sure that all 3 DC load-break switches have been switched off and secured against reconnection.

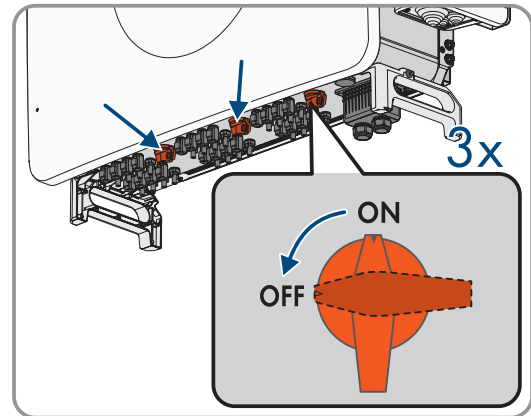

3. Open the cable compartment (see Section 7, page 31).
4. Dismantle the AC cable (≤ 375 mm).
If the optional AC sealing plate is used, dismantle all 4 cables.
5. Strip the insulation of L1, L2, L3, N and the grounding conductor ().
6. For conductors made of aluminum, remove the oxide film and apply protective grease to the conductors.

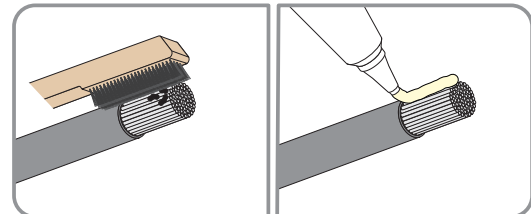

7. Cut the sealing plate of the AC connection at the bottom of the inverter according to the cable diameter.

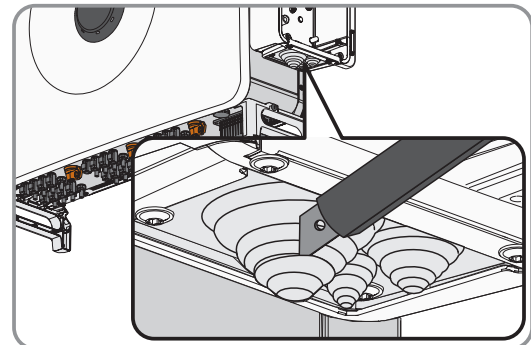

8. Route the cable through the sealing plate for the AC connection into the device.

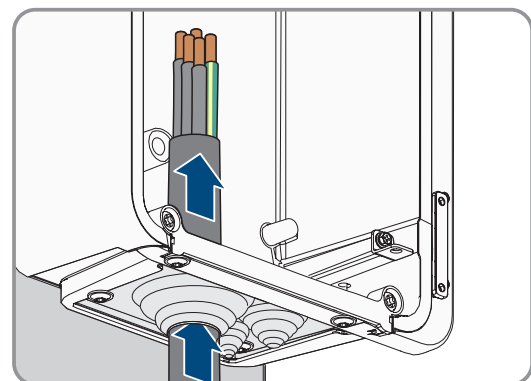

9. Open the protective cover.

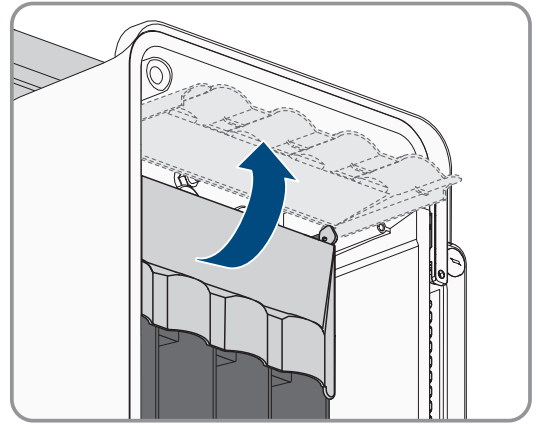

10. Pull 1 heat-shrink tubing each over conductors L1, L2, L3, N and the grounding conductor. The heat-shrink tubing must be below the stripped conductor section.

11. Place the conductors with ring terminal lugs as labeled for L1, L2, L3, N incl. 1 washer and hex nut each onto the stud bolts (M12, torque: 20 Nm to 30 Nm) at the top. Now tighten it all using a ratchet.

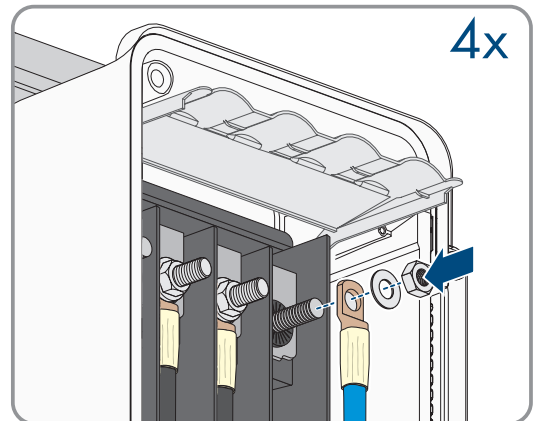

12. Place the grounding conductor incl. 1 washer and hex nut onto the stud bolt (M12, tightening torque: 20 Nm to 30 Nm) in the middle section. Now tighten it all using a ratchet.

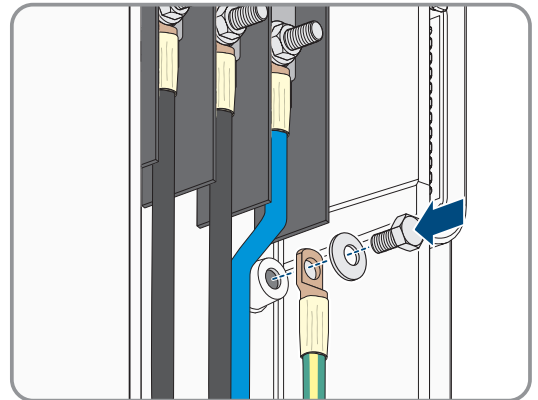

13. Ensure that the AC cable is not under tension.

14. Close the protective cover of the cable compartment.

15. Move the limiting lever back to its original position and close the cable compartment cover.

16. Tighten the 2 screws on the cable compartment cover (TX30, tightening torque: 4.2 Nm to 4.5 Nm).

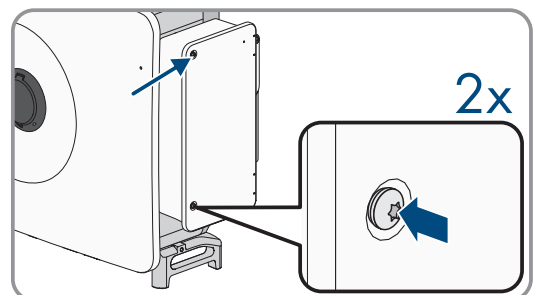

9.5 Connecting the external protective grounding

⚠ QUALIFIED PERSON

An additional grounding of the inverter is required to protect from touch current in case the grounding conductor fails at the terminal of the AC cable.

The inverter features a ground connection with 2 connection points for grounding (e.g., when using a grounding electrode).

The connection points have been labeled with the following symbol: ⊕

The required screw (M8) and washer are included in the inverter's scope of delivery (pre-assembled).

Additionally required material (not included in the scope of delivery):

- 1 heat-shrink tubing

Procedure:

1. Strip the grounding cable insulation.
2. Pull the heat-shrink tubing over the grounding cable. The heat-shrink tubing must be below of the stripped cable section Crimp the heat-shrink tubing.
3. Tighten the grounding cable to the ground connection with washer and screw (M8, tightening torque 7 Nm to 9 Nm) using a screwdriver.

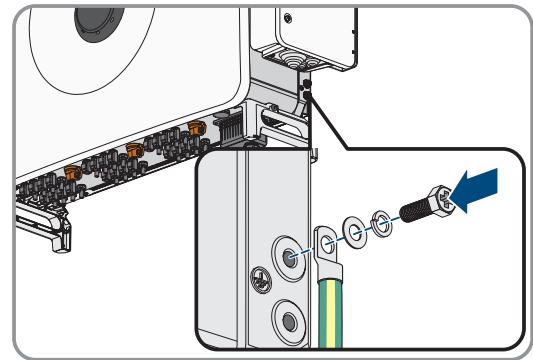

9.6 Connecting the Network Cables

⚠ QUALIFIED PERSON

⚠ DANGER

Danger to life due to electric shock in case of overvoltages and if surge protection is missing

Overvoltages (e.g., in the event of a flash of lightning) can be further conducted into the building and to other connected devices in the same network via the network cables or other data cables if there is no surge protection. Touching live parts and cables results in death or lethal injuries due to electric shock.

- Ensure that all devices in the same network are integrated in the existing overvoltage protection.
- When laying the network cable outdoors, ensure that there is suitable surge protection at the network cable transition from the product outdoors to the network inside the building.

i Refer to the additional installation information in the download area at www.SMA-Solar.com

Additionally required material (not included in the scope of delivery):

- Network cable
- Where required: Field-assembly RJ45 connector.

Procedure:

1. When using a self-assembly network cable, assemble the RJ45 connectors and connect them to the network cable (see connector documentation).
2. Remove the cover from the communication connection area.

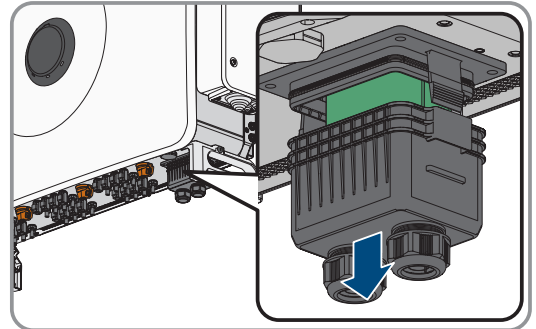

3. Remove the swivel nut from one of the cable glands for the communication cable.
4. Thread the swivel nut over the network cable.
5. Remove the two-hole cable support sleeve from the cable gland. As required, use the cable support sleeve for a cable diameter of between 4.5 mm to 6 mm or between 6 mm to 8 mm that is included in the scope of delivery.
6. Remove the sealing plug from one of the enclosure openings of the two-hole cable support sleeve and insert the network cable into the enclosure opening.

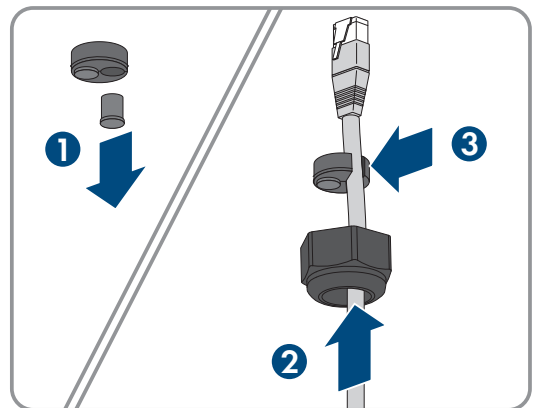

7. Press the two-hole cable support sleeve with the cable into the cable gland and route the network cable to the RJ45 connection at the bottom of the cable compartment. Ensure that any unused enclosure openings of the two-hole cable support sleeve are sealed with sealing plugs.
8. Put the RJ45 plug of the cable into one of the network jacks of the communication assembly.

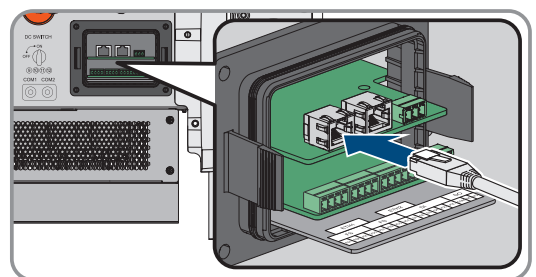

9. Ensure that the RJ45 connector is firmly seated and that there is no tension on the cable.
10. Press the cover of the communication connection area back into the inverter. Slightly pull the connected network cables back when closing the cover so that they are routed as straight as possible on the inside to the cable gland.
11. Tighten the union nut of the cable gland to the cover hand-tight. This will secure the network cable in place.
12. If the inverter is installed outdoors, install overvoltage protection for all components in the network.
13. To integrate the inverter into a local network, connect the other end of the network cable to the local network (e.g., via a router).

9.7 Connection for Active Power Limitation

9.7.1 Procedure for Connecting the Active Power Limitation

Procedure	See
1. Select the function depending on the application.	Section 5.3.4, page 20
2. Connect to the digital input.	Section 9.7.5, page 43
3. Configure the settings for each application during commissioning.	<ul style="list-style-type: none"> For systems with external setpoint specification (see Section 11.15, page 69) For systems with manual setpoint specification (see Section 11.16, page 70)

9.7.2 Digital input DI: D1-D4, Vcc

At the digital input DI: D1-D4, Vcc you can connect a ripple control receiver or a remote terminal unit with which the active power output of the inverter can be limited.

9.7.3 Pin assignment DI: D1-D4, Vcc

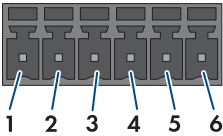
Digital input D1-4	Pin	Labeling on Inverter	Assignment
	1	D1	Digital input 1
	2	D2	Digital input 2
	3	D3	Digital input 3
	4	D4	Digital input 4
	5	Vcc (12 V)	Voltage supply output
	6	Vcc (12 V)	Voltage supply output

9.7.4 Circuitry overview DI: D1-D4, Vcc

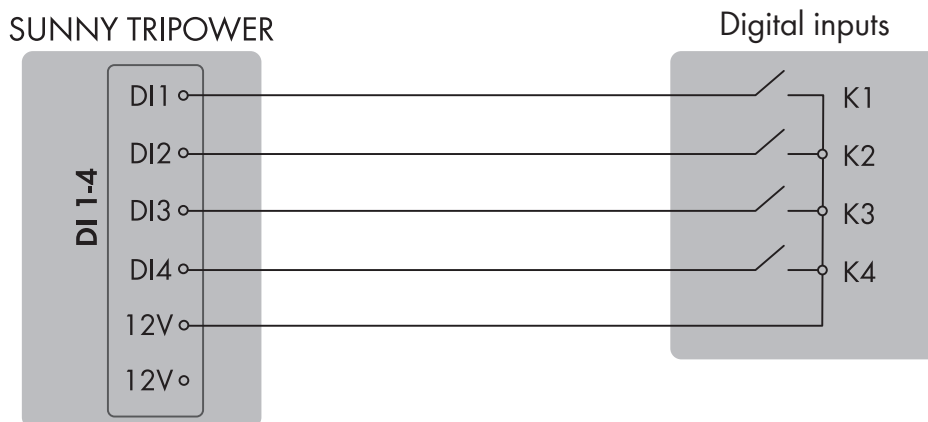
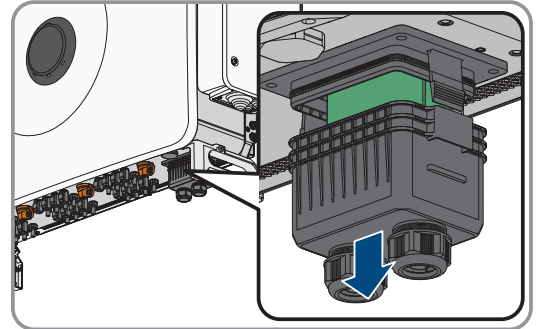

Figure 10: Connection of a remote terminal unit to the digital input DI D1-D4, Vcc of the Sunny Tripower.

9.7.5 Connecting the Digital Input DI: D1-D4, Vcc

⚠ QUALIFIED PERSON

1. Connect the connection cable to the ripple control receiver or the remote terminal unit (see the manual from manufacturer).
2. Disconnect the inverter from voltage sources and secure it against being switched on again (see Section 12, page 79).
3. Remove the cover from the communication connection area.



4. Remove the swivel nut from one of the cable glands for the communication cable.
5. Thread the union nut over the signal cable.
6. Remove the two-hole cable support sleeve from the cable gland. As required, use the cable support sleeve for a cable diameter of between 4.5 mm to 6 mm or between 6 mm to 8 mm that is included in the scope of delivery.
7. Remove the sealing plug from one of the enclosure openings of the two-hole cable support sleeve and insert the cable into the enclosure opening.
8. Strip off a maximum of 6 mm of the cable insulation.
9. Unlock the conductor inserts on the provided 6-pole connector by loosening the screw.
10. Connect the conductors of the connection cable to the supplied 6-pole connector. To do so, plug the conductors into the conductor entries and close the conductor entries by tightening the screws. Observe the connector assignment.
11. Plug the 6-pole connector into the port **DI: D1-D4, Vcc** on the product. Observe the pin assignment.
12. Ensure that the connector is securely in place.
13. Ensure that all conductors are correctly connected.
14. Ensure that the conductors sit securely in the terminal points.
15. Tighten the swivel nut on the cable gland hand-tight.

9.8 Connection for Digital Fast-Stop Inputs

9.8.1 Procedure for Connecting to the Fast-Stop Input

Procedure	See
1. Select the function depending on the application.	• Section 5.3.6, page 20

Procedure	See
2. Connect the contact for fast stop to the digital input.	<ul style="list-style-type: none"> Section 9.8.5, page 45
3. Activate the function either during commissioning in the Grid Management Service step of the inverter's installation assistant or subsequently via the settings in the inverter's user interface.	<ul style="list-style-type: none"> Configuration using the installation assistant (see Section 10.4, page 57) Fast-stop settings via the inverter's user interface (see Section 11.32, page 77) Grid and PV system protection settings via the inverter's user interface (see Section 11.33, page 77)

9.8.2 Pin assignment for fast stop

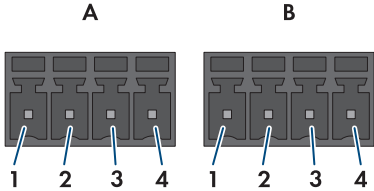
Digital input	Terminal	Pin	Assignment
	A	1	FS1
		2	FS2
		3	Vcc
		4	Vcc
	B	1	FS1
		2	FS2
		3	Vcc
		4	Vcc

Also see:

- Overview of the COM assembly connections ⇒ page 37

9.8.3 Fast stop circuitry overview to realize the grid and PV system protection

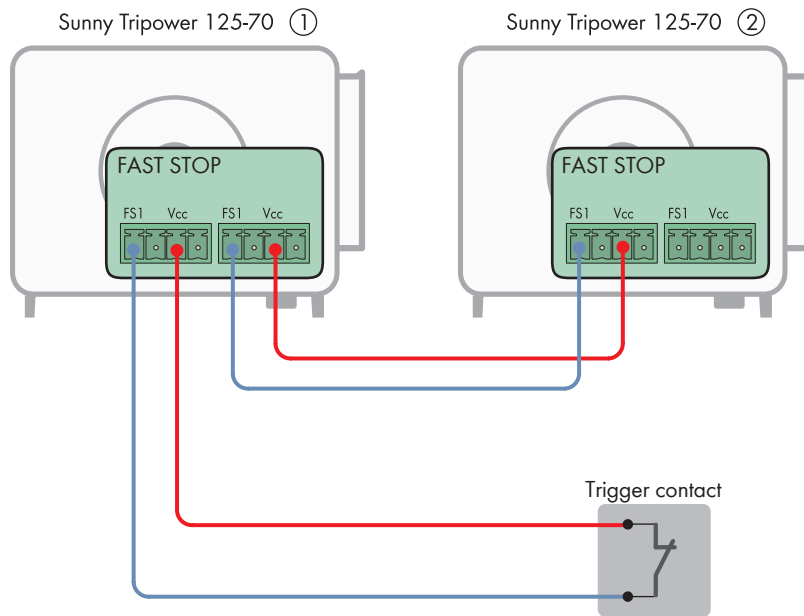

Figure 11: Example of the circuitry for connecting a trigger contact via an external monitoring unit for implementing grid and PV system protection and connecting several inverters (tripping time < 100 ms).

9.8.4 Fast stop circuitry overview for universal applications

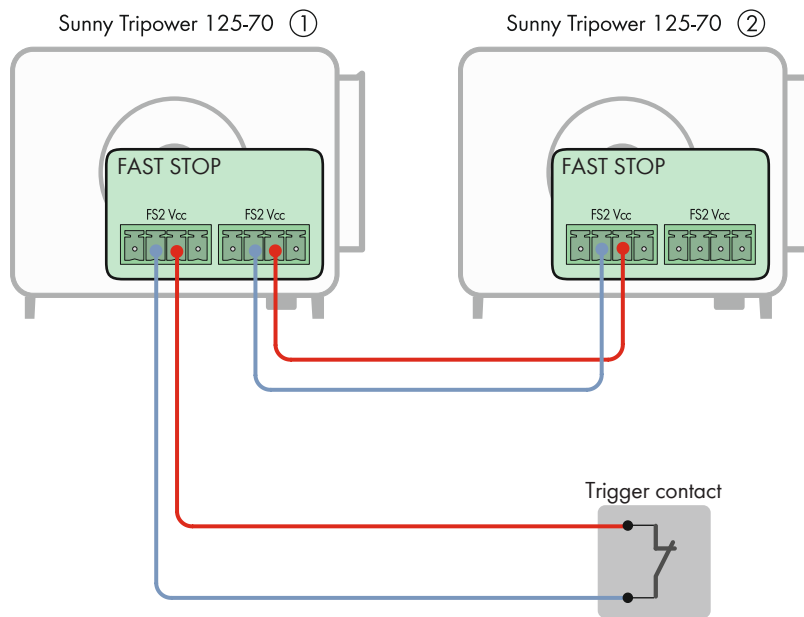

Figure 12: Example of the circuitry for connecting a trigger contact via an external switch for the fast stop and linking multiple inverters (tripping time < 1 s).

9.8.5 Connecting contact for fast stop to digital input

⚠ QUALIFIED PERSON

i Observe pin assignment for grid and PV system protection

Note that when connecting the grid and PV system protection required by VDE-AR-N-4105, the connection must be made to the pin with the **FS1** assignment. The pin with the **FS2** assignment is considered a universal connection and is unsuitable for implementing grid and PV system protection. It is used for the connection of an external switch, for example.

The inputs are provided twice and allow the parallel connection of several inverters. To guarantee a reliable function through parallel connection of several devices, only inverters of the same type may be used.

Additional required material (not included in the scope of delivery):

- External disconnecting device with potential-free contact to trigger the fast stop function

Procedure:

1. Connect the connection cable to the contact for the fast stop (see the manual from manufacturer).
2. Disconnect the inverter from voltage sources and secure it against being switched on again (see Section 12, page 79).
3. Open the cable compartment (see Section 7, page 31).
4. Strip off 7 mm of the conductor insulation from each of the connection cable conductors.
5. Remove the cover from the communication connection area.

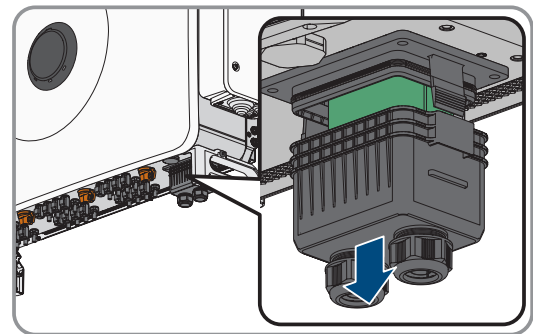

6. Remove the swivel nut from an unused cable gland for communication cables.
7. Thread the swivel nut over the connection cable.
8. Remove the two-hole cable support sleeve from the cable gland. As required, use the cable support sleeve for a cable diameter of between 4.5 mm to 6 mm or between 6 mm to 8 mm that is included in the scope of delivery.
9. Remove the sealing plug from one of the enclosure openings of the two-hole cable support sleeve and insert the connection cable into the enclosure opening. Ensure that the connection cable is located about 15 cm within the cover so as not to damage the cable connection when pulling off the cover.
10. Press the two-hole cable support sleeve with the cable into the cable gland and route the connection cable to the COM assembly at the bottom of the cable compartment. Ensure that any unused enclosure openings of the two-hole cable support sleeve are sealed with sealing plugs.
11. Remove the terminal block incl. connection area **FS** from the COM assembly.
12. Insert the stripped conductors up to the stop into the terminal points **FS1** or **FS2** and **Vcc** and fasten with a flat-blade screwdriver (tightening torque: 0.2 Nm).
13. Ensure that the conductors are plugged into the terminal points tightly by pulling slightly on the conductors.
14. Plug the terminal block onto the COM assembly according to labeling.
15. Tighten the swivel nut on the cable gland hand-tight. This will secure the connection cable in place.
16. For the fast stop connection: configure function Activating the fast stop function.
17. For the grid and PV system protection connection: configure function (see Section 11.33, page 77).

Also see:

- [Fast stop circuitry overview to realize the grid and PV system protection](#) ⇒ page 45
- [Fast stop circuitry overview for universal applications](#) ⇒ page 45

9.9 Connection to the Multifunction Relay

9.9.1 Procedure for Connecting the Multifunction Relay

Procedure	See
1. Select the operating mode of the multifunction relay according to the application.	Section 11.30, page 76
2. Connect to the multifunction relay according to the operating mode and the associated connection variant.	Section 9.9.4, page 50
3. Change the operating mode after commissioning the inverter via the settings in the inverter user interface.	Section 11.31, page 77

9.9.2 Pin assignment for multifunction relay

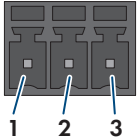
Digital input	Pin	Assignment
	1	NC
	2	COM
	3	NO

Also see:

- [Overview of the COM assembly connections](#) ⇒ page 37

9.9.3 Application Examples

9.9.3.1 Using the Multifunction Relay as a Fault Indicator Contact

You can use the multifunction relay as a fault indicator contact and have an error or smooth operation of the inverter displayed or signaled via a suitable display device. You can connect multiple inverters to a single fault indicator or operation indicator if necessary.

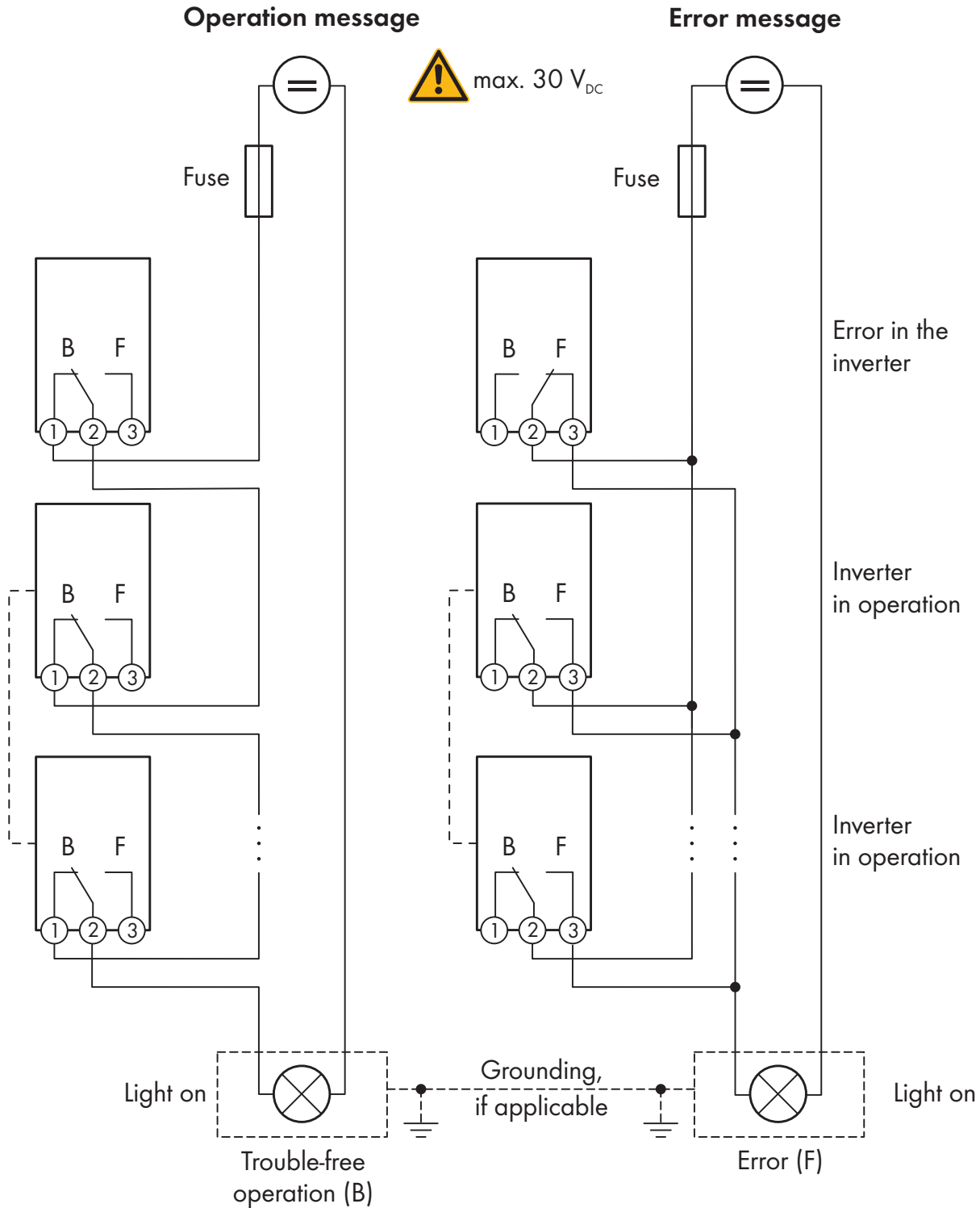

Figure 13: Circuit diagram with multiple inverters for connection to an operation indicator and circuit diagram for connection to a fault indicator (example)

9.9.3.2 Controlling loads via the multifunction relay or charging batteries depending on the power production of the PV system

The multifunction relay can control loads or charge batteries power-dependently. To enable this function, you must connect a contactor (K1) to the multifunction relay. The contactor (K1) switches the operating current for the load on or off. If you want batteries to be charged depending on the available power, the contactor activates or deactivates the charging of the batteries.

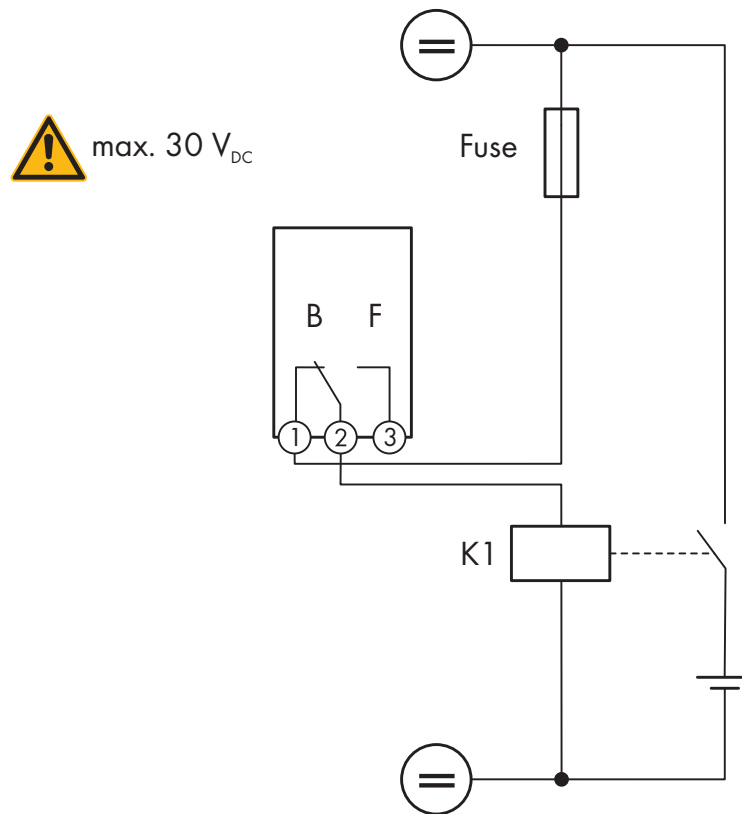

Figure 14: Wiring diagram for connection for controlling a load or for the power-dependent charging of the batteries

9.9.3.3 Reporting the switching status of the grid relay

The multifunction relay can trip a signal to the grid operator as soon as the inverter connects to the utility grid. To enable this function, the multifunction relays of all inverters must be connected in parallel.

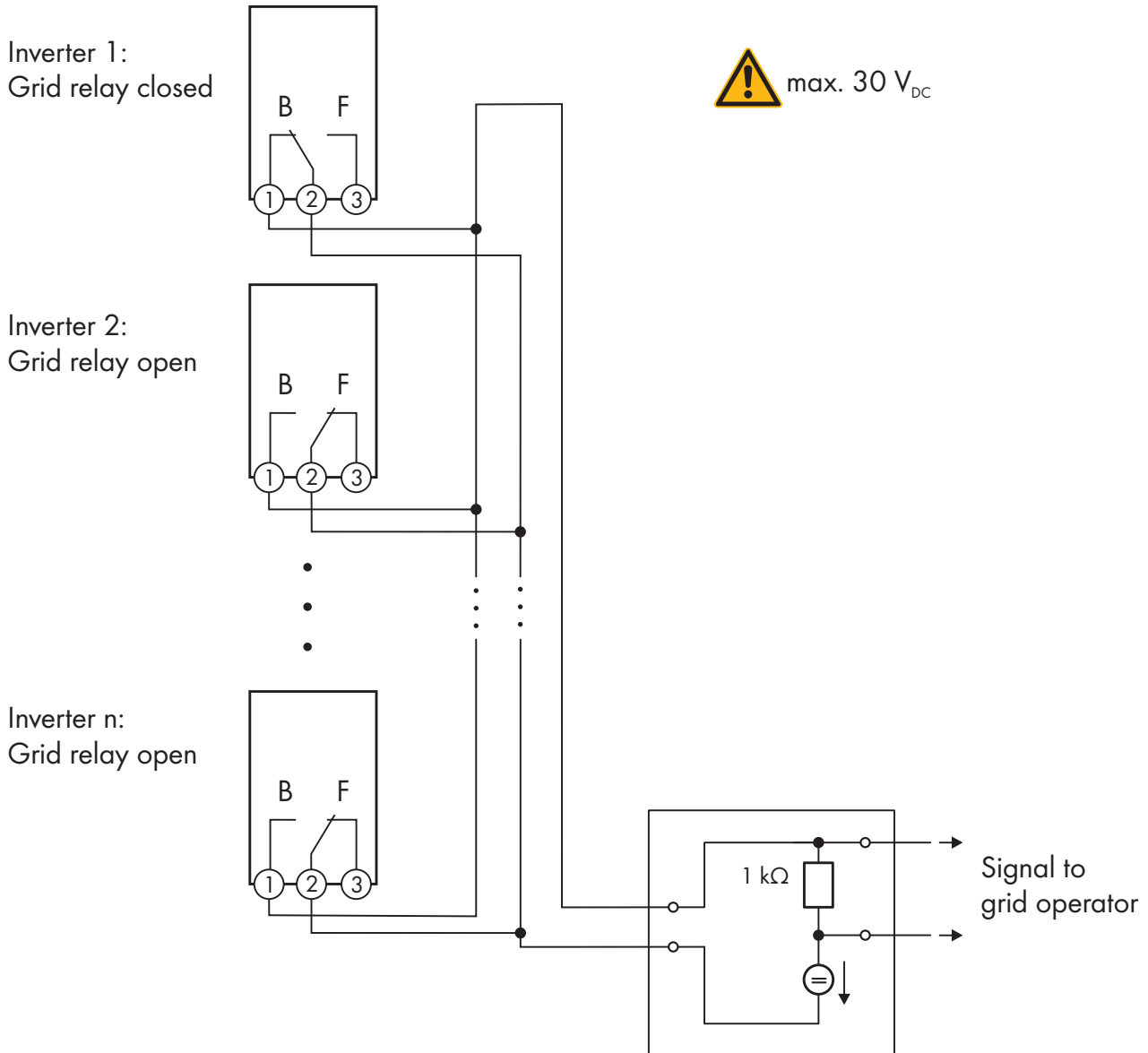

Figure 15: Wiring diagram for signaling the switching status of the grid relay (example)

9.9.4 Connecting the Multifunction Relay

The multifunction relay of the inverter is designed as a potential-free change-over contact (NO / NC / COM). Various status messages can be displayed depending on the configuration of the operating mode Operating Modes of the Multifunction Relay.

Cable requirements:

- The cable type and cable-laying method must be appropriate for the application and location.

Procedure:

1. Remove the cover from the communication connection area.

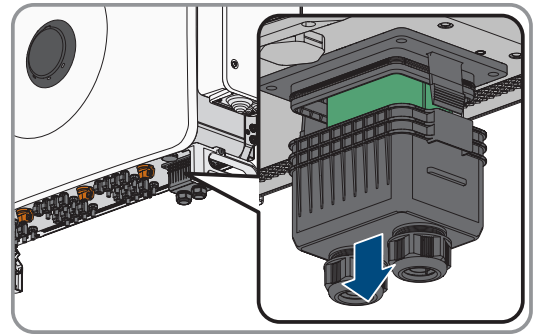

2. Remove the swivel nut from one of the cable glands for the communication cable.
3. Thread the swivel nut over the cable.
4. Remove the two-hole cable support sleeve from the cable gland. As required, use the cable support sleeve for a cable diameter of between 4.5 mm to 6 mm or between 6 mm to 8 mm that is included in the scope of delivery.
5. Remove the sealing plug from one of the enclosure openings of the two-hole cable support sleeve and insert the cable into the enclosure opening.
6. Strip off a maximum of 6 mm of the cable insulation.
7. Unlock the conductor inserts on the provided 3-pole connector by loosening the screw.
8. Connect the conductors of the connection cable to the supplied 3-pole connector. To do so, plug the conductors into the conductor entries and close the conductor entries by tightening the screws. Observe the connector assignment.
9. Plug the 3-pole connector into the socket **D0: COM, NC, NO** on the product. Observe the pin assignment.
10. Ensure that the connector is securely in place.
11. Ensure that all conductors are correctly connected.
12. Ensure that the conductors sit securely in the terminal points.
13. Tighten the swivel nut on the cable gland hand-tight.

9.10 DC connection

9.10.1 Overview of DC connectors

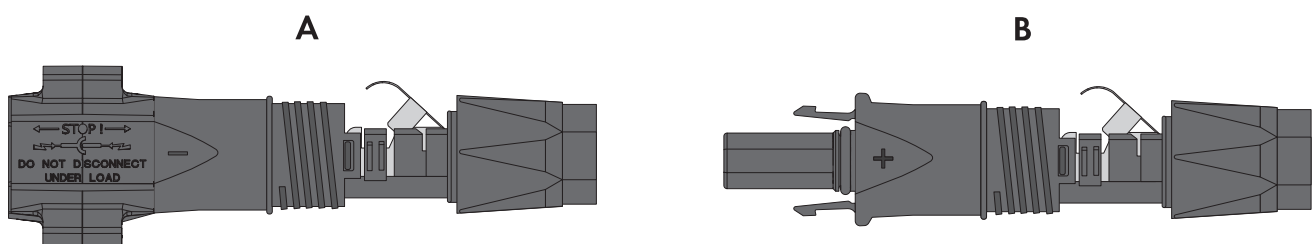

Figure 16: Negative (A) and positive (B) DC connectors

9.10.2 Assembling the DC Connectors

⚠ QUALIFIED PERSON

For connection to the inverter, all PV module connection cables must be fitted with the DC connectors provided. Assemble the DC connectors as described in the following. The procedure is identical for both connectors (+ and -). The graphics for the procedure are shown for only the positive connector as an example. Pay attention to the correct polarity when assembling the DC connectors. The DC connectors are marked with the symbols "+" and "-".

⚠ DANGER

Danger to life due to electric shock when live components or DC cables are touched

When exposed to light, the PV modules generate high DC voltage which is present in the DC cables. Touching live DC cables results in death or lethal injuries due to electric shock.

- Do not touch non-insulated parts or cables.
- Disconnect the product from voltage sources and ensure it cannot be reconnected before working on the device.
- Do not disconnect the DC connectors under load.
- Wear suitable personal protective equipment for all work on the product.

NOTICE

Destruction of the inverter due to overvoltage

If the open-circuit voltage of the PV modules exceeds the maximum input voltage of the inverter, the inverter can be destroyed due to overvoltage.

- If the open-circuit voltage of the PV modules exceeds the maximum input voltage of the inverter, do not connect any strings to the inverter and check the design of the PV system.

Procedure:

1. Strip approx. 15 mm of the cable insulation.
2. Insert the stripped cable into the DC connector up to the stop. When doing so, ensure that the stripped cable and the DC connector are of the same polarity.
3. Press the clamping bracket down until it audibly snaps into place.

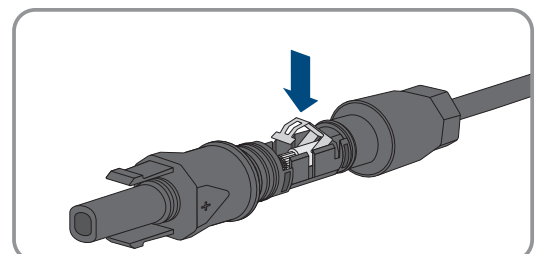
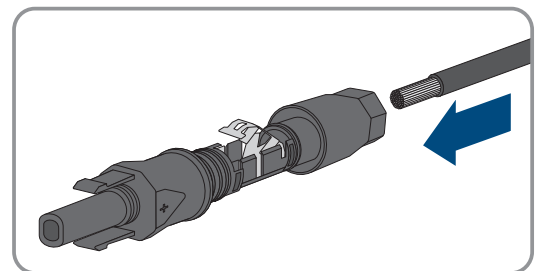

- ☑ The stranded wire can be seen inside the clamping bracket chamber.

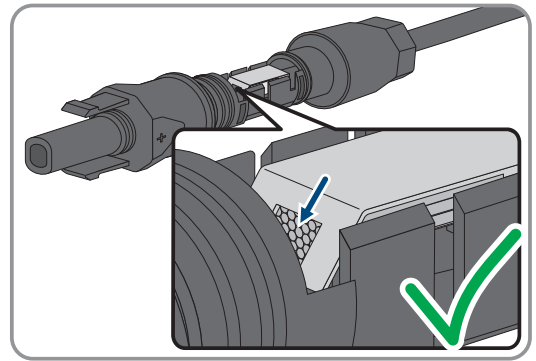

4. If the stranded wire is not visible in the chamber, the cable is not correctly inserted and the connector must be reassembled. To do this, the cable must be removed from the connector.
5. To take out the cable, loosen the clamping bracket. To do so, insert a screwdriver (blade width: 3.5 mm) into the clamping bracket and pry the clamping bracket open.

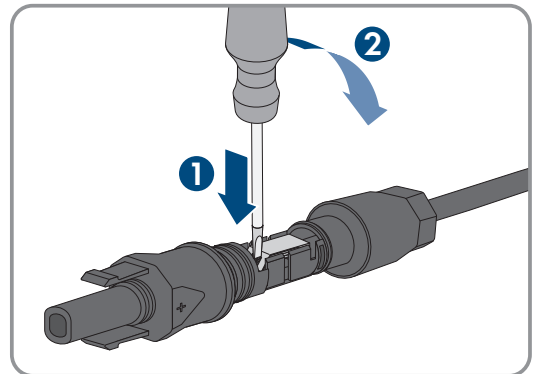

6. Remove the cable and go back to step 2.
7. Push the swivel nut up to the thread and tighten (torque: 2 Nm).

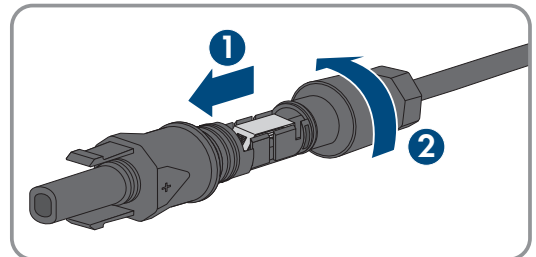

9.10.3 Connecting the PV Array

⚠ QUALIFIED PERSON

⚠ DANGER

Danger to life due to electric shock when live components or DC cables are touched

When exposed to light, the PV modules generate high DC voltage which is present in the DC cables. Touching live DC cables results in death or lethal injuries due to electric shock.

- Do not touch non-insulated parts or cables.
- Disconnect the product from voltage sources and ensure it cannot be reconnected before working on the device.
- Do not disconnect the DC connectors under load.
- Wear suitable personal protective equipment for all work on the product.

⚠ WARNING**Danger to life due to electric shock from destruction of the measuring device due to overvoltage**

Overvoltage can damage a measuring device and result in voltage being present in the enclosure of the measuring device. Touching the live enclosure of the measuring device results in death or lethal injuries due to electric shock.

- Only use measuring devices with a measurement ranges designed for the maximum AC and DC voltage of the inverter.

NOTICE**Destruction of the inverter due to overvoltage**

If the open-circuit voltage of the PV modules exceeds the maximum input voltage of the inverter, the inverter can be destroyed due to overvoltage.

- If the open-circuit voltage of the PV modules exceeds the maximum input voltage of the inverter, do not connect any strings to the inverter and check the design of the PV system.

NOTICE**Damage to the product due to sand, dust and moisture ingress if the DC inputs are not closed**

The product is only properly sealed when all unused DC inputs are closed with DC connectors or sealing plugs. Sand, dust and moisture penetration can damage the product and impair its functionality.

- Do not remove the sealing plugs from DC inputs that are not required.

Procedure:

1. Ensure that the AC miniature circuit breaker is switched off and that it cannot be reconnected.
2. Switch off the 3 DC load-break switches of the inverter.

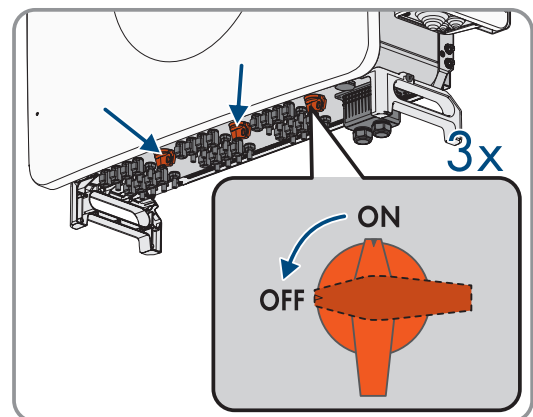

3. Measure the PV array voltage. Ensure that the maximum input voltage of the inverter is adhered to and that there is no ground fault in the PV array.
4. Check whether the DC connectors have the correct polarity. If the DC connector is equipped with a DC cable of the wrong polarity, the DC connector must be reassembled. When this is done, the respective DC cable must always have the same polarity as the DC connector.
5. Ensure that the open-circuit voltage of the PV array does not exceed the maximum input voltage of the inverter.

6. Connect the assembled DC connectors to the inverter.

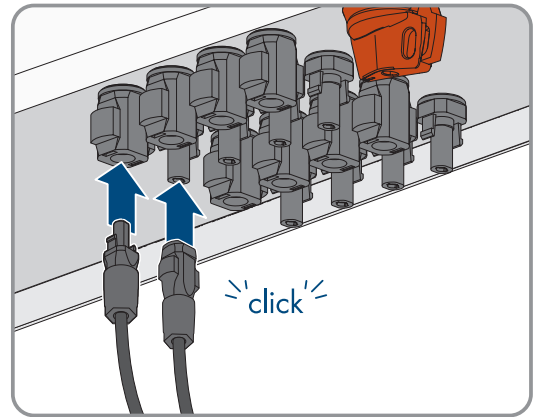

☑ The DC connectors snap into place.

7. For unused DC connectors, push down the clamping bracket and push the swivel nut up to the thread.

8. Insert the sealing plug into the DC plug connector.

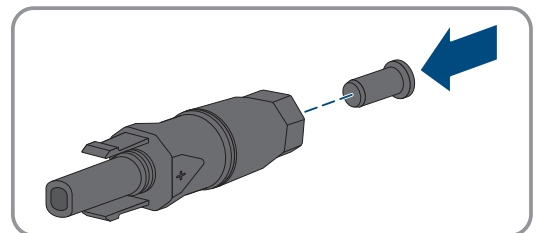

9. Insert the DC connectors with sealing plugs into the corresponding DC inputs of the inverter.

☑ The DC connectors snap into place.

10. Ensure that all DC connectors are securely in place.

10 Commissioning

10.1 Procedure for commissioning in systems without System Manager

⚠ QUALIFIED PERSON

This section describes the commissioning procedure for an inverter used in systems without a System Manager (e.g., SMA Data Manager M). The commissioning is carried out via the inverter's user interface.

It provides an overview of the steps, which must be performed in the prescribed sequence.

Procedure	See
1. Commission the inverter.	Section 10.3, page 57
2. Establish a connection to the user interface of the inverter. There are various connection options to choose from for this: <ul style="list-style-type: none"> • Direct connection via Wi-Fi • Connection via Wi-Fi in the local network • Connection via Ethernet in the local network 	Section 11.1, page 59
3. Log into the user interface.	Section 11.8, page 67
4. Update the firmware.	Section 11.29, page 76
5. Carry out the configuration using the installation assistant and set the country data set. Then the product will begin operation.	Section 11.10, page 68
6. Make further inverter settings as needed.	Section 11, page 59

10.2 Procedure for commissioning in systems with System Manager

This section describes the commissioning procedure for an inverter used in systems with a System Manager (e.g., SMA Data Manager M). In this case, the inverter is controlled or regulated by the System Manager.

It provides an overview of the steps, which must be performed in the prescribed sequence.

Procedure	See
1. Commission the inverter.	Section 10.3, page 57
2. Commission the System Manager.	Manual of the System Manager
3. Register the inverter as an SMA Speedwire device in the System Manager and make the initial configuration of the inverter via the System Manager. The configuration is transferred to the inverter and the settings of the inverter are overwritten.	Commissioning Assistant of the System Manager
4. Establish a connection to the user interface of the inverter. There are various connection options to choose from for this: <ul style="list-style-type: none"> • Direct connection via Wi-Fi • Connection via Wi-Fi in the local network • Connection via Ethernet in the local network 	Section 11.1, page 59
5. Log into the user interface.	Section 11.8, page 67
6. Update the firmware.	Section 11.29, page 76

Procedure	See
7. Ensure that the country data set has been configured correctly.	Section 11.27, page 75
8. Make further inverter settings as needed.	Section 11, page 59

10.3 Switching the Inverter On

Requirements:

- The AC circuit breaker must be correctly rated and mounted.
- The product must be correctly mounted.
- All cables for the AC connection, DC connection, and communication must be correctly connected.
- Unused enclosure openings must be sealed tightly with sealing plugs.

Procedure:

1. Make sure that the AC cable compartment is closed.
2. Switch on all 3 DC load-break switches.

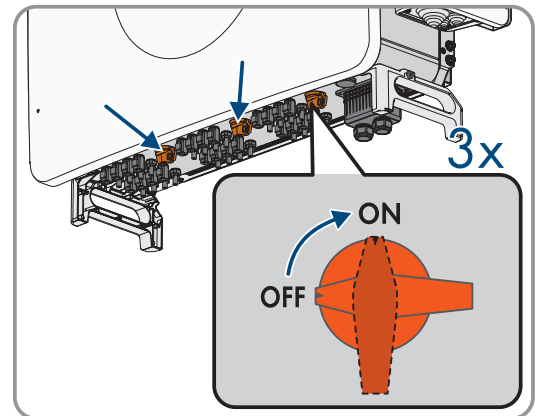

3. Switch the AC voltage supply on.
 - Green LED is flashing. The inverter is waiting for the input conditions.
4. Perform the configuration of the inverter (see Section 10.4, page 57).
 - After approx. 90 seconds, the green LED is permanently on. The inverter is feeding in.
5. Ensure that the inverter feeds in correctly.

10.4 Carry out the configuration using the installation assistant

⚠ QUALIFIED PERSON

The installation assistant helps you to configure the inverter and guides you to the most important settings.

Requirements:

- You are logged in as **Installer**, and the user interface is open on the **Configuring the Inverter** page.

Procedure:

1. Select the configuration option **Configuration with Installation Assistant**.
 - The installation assistant will open.
2. Follow the installation assistant steps and make the settings appropriate for your system.
3. For every setting made in a step, select [**Save and next**].
 - In the last step, all made settings are listed in a summary.

4. To correct settings you made, select [**Back**], navigate to the desired step, correct settings and select [**Save and continue**].
 5. To export all parameters and their settings, select [**Export all parameters**]. This exports all parameters and their settings into an HTML file.
 6. Once all settings are correct, select [**Next**] in the summary.
 7. To save the settings to a file, select [**Export a summary**] and save the file on your smart device.
- The start page of the user interface opens.

Also see:

- [Logging Into the User Interface](#) ⇒ page 67
- [Layout of the installation assistant](#) ⇒ page 63

10.5 Adopting the Configuration from a File

QUALIFIED PERSON

You can adopt the inverter configuration from a file. To do this, there must be an inverter configuration saved to a file.

Requirements:

- You are logged in as **Installer**, and the user interface is open on the **Configuring the Inverter** page.

Procedure:

1. Select the configuration option **Adopt the configuration from a file**.
2. Select [**Browse...**] and select the desired file.
3. Select [**Import file**].

10.6 Carry out the configuration manually

QUALIFIED PERSON

You can configure the inverter manually by setting the desired parameters.

Requirements:

- You are logged in as **Installer**, and the user interface is open on the **Configuring the Inverter** page.

Procedure:

1. Select the configuration option **Manual Configuration**.
 - The **Device Parameters** menu on the user interface will open and all available parameter groups of the inverter will be displayed.
 2. Click on [**Edit parameters**].
 3. Select the desired parameter group.
 - All available parameters of the parameter group will be displayed.
 4. Set the desired parameters.
 5. Select [**Save all**].
- The inverter parameters are set.

Also see:

- [Logging Into the User Interface](#) ⇒ page 67

11 Operation

11.1 Establishing a Connection to the User Interface

11.1.1 Establishing a Direct Connection via Ethernet

i IP address of the product

- Default IP address of the product for direct connection via Ethernet: **169.254.12.3**

i Usage of cookies

For the correct display of the user interface, cookies are required. The cookies are used for convenience only. By using this user interface you agree to the placement of cookies.

Requirements:

- An end device (e.g. laptop) with an Ethernet interface must be available.
- The product must be connected directly to the end device.

Procedure:

1. Open the web browser of your end device.
 2. Enter the IP address **169.254.12.3** into the address bar and press the enter key.
 3. **i** **Web browser displays warning**
After the access address of the product has been entered, a message might appear indicating that the connection to the user interface of the product is not secure.
 - Continue loading the user interface (scroll to bottom and click proceed/advance).
- The login page of the user interface opens.

Also see:

- [Logging Into the User Interface](#) ⇒ page 67

11.1.2 Direct connection via Wi-Fi

11.1.2.1 Connection options for Wi-Fi direct connection

You have several options to connect the product to a smart device. The procedure can be different depending on the devices. If the procedures described do not apply to your end device, establish the direct connection via Wi-Fi as described in the manual of your end device.

The following connection options are available:

- Direct Wi-Fi connection with WPS Establishing a direct Wi-Fi connection with WPS
- Direct Wi-Fi connection with Wi-Fi network search Establishing direct Wi-Fi connection with Wi-Fi network search

11.1.2.2 Requirements for Direct Connection via Wi-Fi

- The product must be commissioned.
- A smart device (e.g., smartphone, tablet or laptop) must be available.
- The respective latest version of one of the following web browsers must be installed on the smart terminal device: Chrome, Edge, Firefox or Safari.
- JavaScript must be enabled in the web browser of the smart device.

11.1.2.3 Access information for direct Wi-Fi connection

i Communication disturbances in the local network

The IP address range 192.168.12.0 to 192.168.12.255 is reserved for the SMA-internal data exchange and cannot be used for system communication within the local network.

Communication problems might occur if this IP address range is used in the local network.

- Do not use the IP address range 192.168.12.0 to 192.168.12.255 in the local network.

Access information for the direct WiFi connection can be found below:

- SSID: **https://SMA[serial number]** (e.g. SMA0123456789)
- Device-specific Wi-Fi password: WPA2-PSK (see type label of the product)
- Default access address: **https://smalogin.net** or **https://192.168.12.3**

11.1.2.4 Establishing a direct Wi-Fi connection with the 360° app

Requirements:

- A smart device with camera (e.g. smartphone or tablet) must be available.
- The SMA 360° App must be installed on the smart device.
- An user account for Sunny Portal must already exist.

Procedure:

1. Open the SMA 360° App and login with the Sunny Portal account details.
2. Select **Setup** in the menu.
3. Select **Access user interface** in the menu.
4. Select **Enable scanner** in the menu.
5. Scan the QR Code on you product via the SMA 360° App.
 - The smart device automatically connects to the product. The web browser of your smart device opens and the login page of the user interface is displayed.
6. If the web browser of the smart end device does not open automatically and the login page of the user interface is not displayed, open the web browser and enter **http://smalogin.net** in the address bar.

11.1.2.5 Establishing direct Wi-Fi connection with Wi-Fi network search

1. Search for Wi-Fi networks with your smart device.
2. Select the SSID of the product **SMA[serial number]** in the list with the detected Wi-Fi networks.
3. Enter the device-specific Wi-Fi password (see WPA2-PSK on the type label).
4. Open the web browser of your smart end device and enter **http://smalogin.net** in the address bar.
 - The login page of the user interface is displayed.
5. If the login page of the user interface does not open, enter the IP address **192.168.12.3** or, if your smart device supports mDNS services, **SMA[serial number].local** or **http://SMA[serial number]** in the address bar of the web browser.

11.1.3 Connection in the local network

11.1.3.1 Access addresses for the product in the local network

i Communication disturbances in the local network

The IP address range 192.168.12.0 to 192.168.12.255 is reserved for internal communication and direct access between SMA products and cannot be used for system communication within the local network.

Communication problems might occur if this IP address range is used in the local network.

- Do not use the IP address range 192.168.12.0 to 192.168.12.255 in the local network.

If the product is connected to a local network (e.g. via an Internet router or Wi-Fi), the product will receive a new IP address. Depending on the type of configuration, the new IP address will be assigned automatically by the DHCP server (Internet router) or manually by you.

Upon completion of the configuration, the product can only be reached via the listed access addresses in the local network:

- Generally applicable access address: IP address manually assigned or assigned by the DHCP server (Internet router) (identification via network scanner software or network configuration of the Internet router).
- Access address: **https://SMA[serial number]** (e.g. **https://SMA0123456789**)

11.1.3.2 Establishing a Connection via Ethernet in the local network

i Usage of cookies

For the correct display of the user interface, cookies are required. The cookies are used for convenience only. By using this user interface you agree to the placement of cookies.

Requirements:

- The product must be connected to the local network via a network cable (e.g. via a router).
- The product must be integrated into the local network. Tip: There are various methods of integrating the product into the local network with the aid of the installation assistant.
- The end device (e.g. laptop or tablet) must be in the same local network as the product.

Procedure:

1. Open the web browser of your end device.
2. Enter the IP address of the product into the address bar and press the enter key.

3. **i** Web browser displays warning

After the access address of the product has been entered, a message might appear indicating that the connection to the user interface of the product is not secure.

- Continue loading the user interface (scroll to bottom and click proceed/advance).

- The login page of the user interface opens.

Also see:

- [Logging Into the User Interface](#) ⇒ page 67

11.1.3.3 Establishing a Connection via Wi-Fi in the Local Network

Requirements:

- The product must be commissioned.
- The product must be integrated into the local network.
- A smart terminal device (e.g. laptop) must be available.
- The smart terminal device must be in the same local network as the product.

- The respective latest version of one of the following web browsers must be installed on the smart terminal device: Chrome, Edge, Firefox or Safari.

Procedure:

1. Open the web browser of your smart terminal device.
 2. Enter the access address of the product in the address bar of the web browser.
 3. **i Web browser displays warning**
After the access address of the product has been entered, a message might appear indicating that the connection to the user interface of the product is not secure.
 - Continue loading the user interface (scroll to bottom and click proceed/advance).
- The login page of the user interface is displayed.

11.2 Layout of the 'Configuring the Inverter' page

⚠ QUALIFIED PERSON

After you have assigned the password for the user groups **Installer** and **User** and logged in as **Installer**, the **Configuring the Inverter** page opens.

On the **Configuring the Inverter** page, different configuration options for the first configuration of the device are available to choose from. recommends carrying out the configuration with the installation assistant. This way, you ensure that all relevant parameters are set for optimal inverter operation.

- Adopting the Configuration from a File
- Configuring the Installation Assistant (Recommended)
- Manual configuration

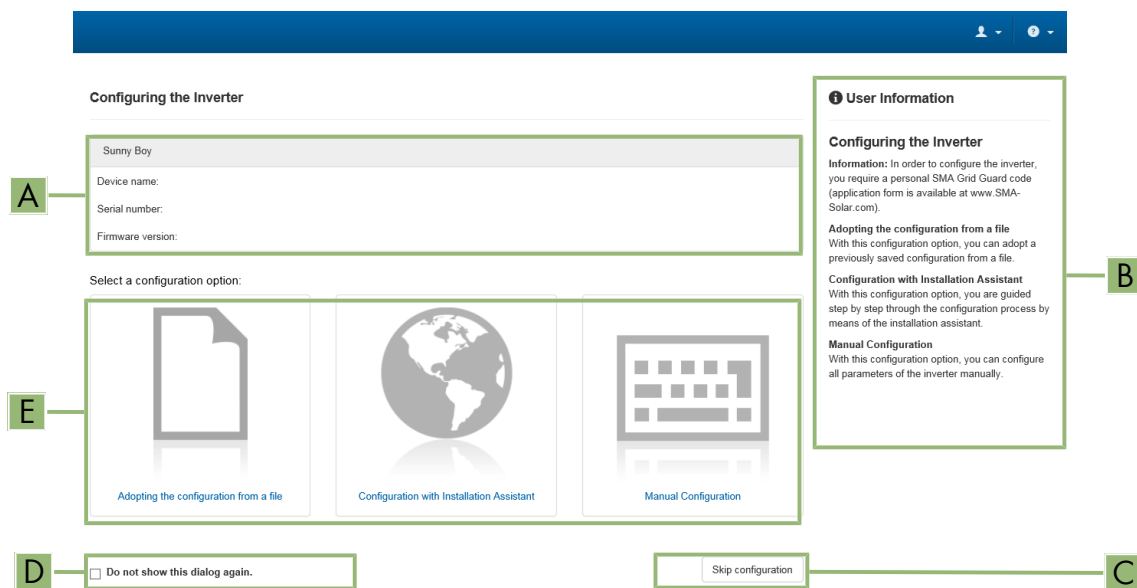

Figure 17: Layout of the **Configuring the Inverter** page

Position	Designation	Description
A	Device information	Provides the following information: <ul style="list-style-type: none"> • Device name • Inverter serial number • Inverter firmware version

Position	Designation	Description
B	User information	Provides brief information on the listed configuration options
C	Skip configuration	Offers the option of skipping the inverter configuration and go directly to the user interface (not recommended)
D	Checkbox	Allows you to choose not to have the displayed page displayed again when the user interface is called up again
E	Configuration options	Provides a selection of the various configuration options

Also see:

- Carry out the configuration using the installation assistant ⇒ page 57
- Adopting the Configuration from a File ⇒ page 58
- Carry out the configuration manually ⇒ page 58

11.3 Layout of the installation assistant

⚠ QUALIFIED PERSON

The installation assistant guides you step-by-step through the steps required for initial configuration of the product.

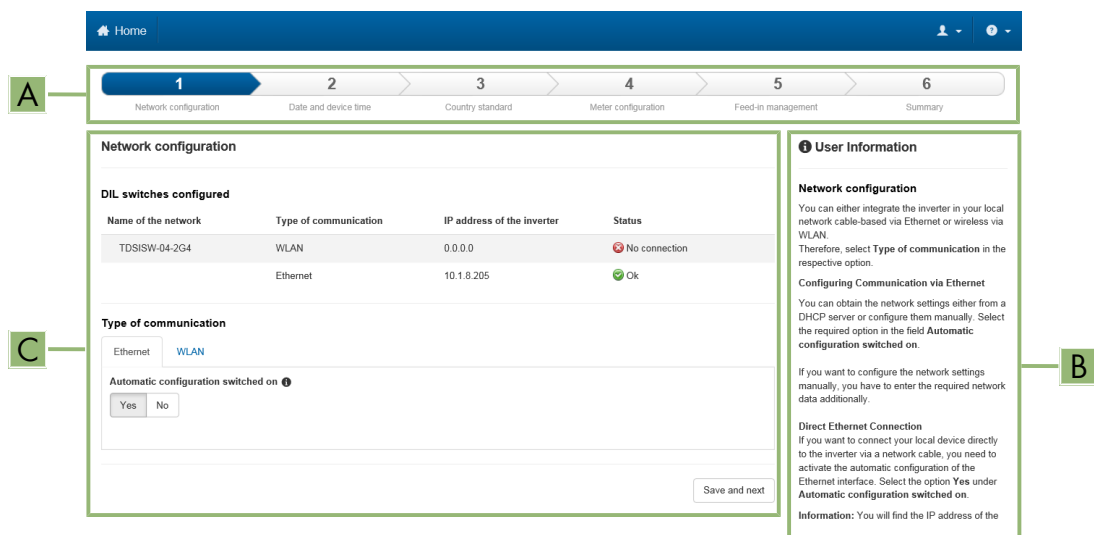

Figure 18: Layout of the installation assistant (example)

Position	Designation	Description
A	Configuration steps	Overview of the installation assistant steps. The number of steps depends on the type of device and the additionally installed modules. The current step is highlighted in blue.
B	User information	Information about the current configuration step and the setting options of the configuration step.
C	Configuration field	You can make settings in this field.

Also see:

- Establishing a Connection to the User Interface ⇒ page 59
- Starting the Installation Assistant ⇒ page 68

11.4 Start Page Design of the User Interface

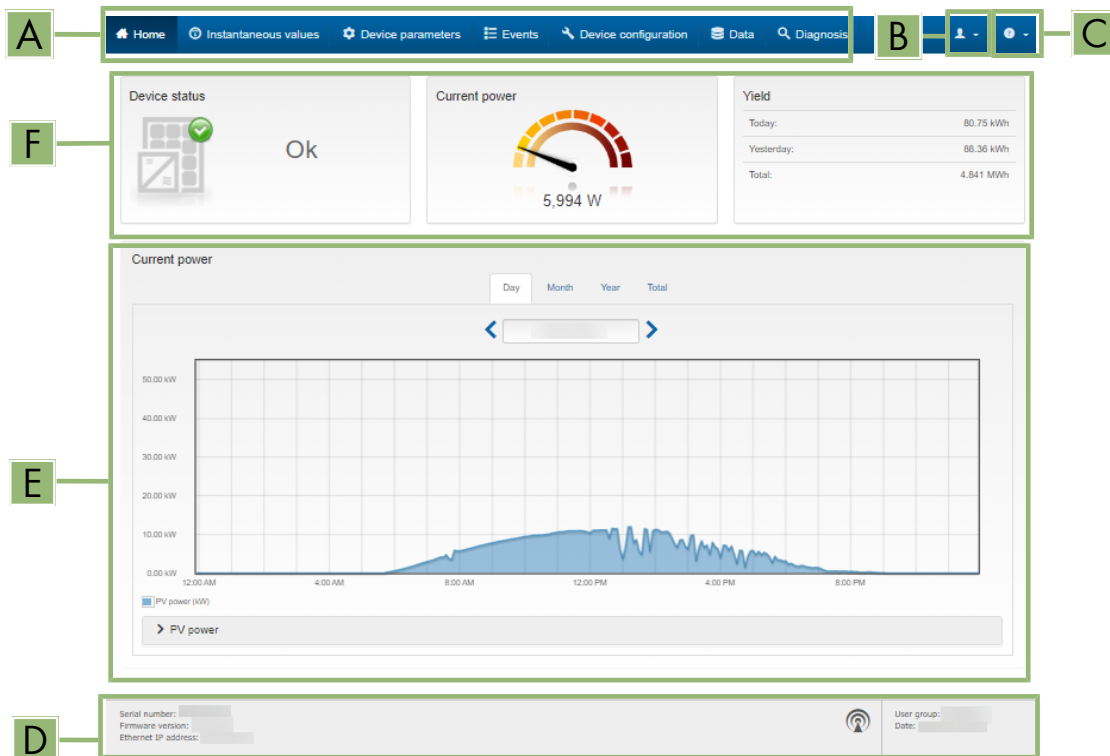

Figure 19: Design of the user interface's home page (example)

Position	Designation	Description
A	Menu	<p>Provides the following functions:</p> <ul style="list-style-type: none"> • Home Opens the user interface home page • Instantaneous Values Current measured values of the inverter • Device Parameters The various operating parameters of the inverter can be viewed and configured here depending on the user group. • Events All events that have occurred in the selected time period are displayed here. The event types are Information, Warning and Error. Currently existing events of the types Error and Warning will be additionally displayed in the Device status viewlet. However, only the higher-priority event is displayed. If, for example, there is a Warning and an Error present at the same time, only the error will be displayed. • Device Configuration Various settings for the inverter can be made here. The selection available is dependent on which user group you are logged in as and the operating system of the device with which the user interface has been called up. • Data You will find all data that is saved in the internal memory of the inverter on this page. • Diagnosis Here, an I-V characteristic curve of the PV array per MPP tracker can be created and exported.
B	User settings	<p>Provides the following functions, depending on the user group logged in:</p> <ul style="list-style-type: none"> • Starting the Installation Assistant • Set access rights • Activating and Deactivating the Smart Inverter Screen • Show eManual • Link to SMA Online Service Center (www.my.sma-service.com) • Logout
C	Help	<p>Provides the following functions:</p> <ul style="list-style-type: none"> • Displaying information on Open Source licenses used • Link to the website of

Position	Designation	Description
D	Status bar	<p>Displays the following information:</p> <ul style="list-style-type: none"> • Serial number of the inverter • Inverter firmware version • IP address of the inverter in the local network • User group logged in • Date and device time of the inverter
E	Current power and current consumption	<p>Temporal progression of the PV power and the power consumption of the household over the selected time period. Please note, the power consumption will only be displayed if an energy meter is installed in the PV system.</p>
F	Status display	<p>The various areas display information on the current status of the PV system.</p> <ul style="list-style-type: none"> • Device status Displays whether the inverter is currently in a fault-free operating state or whether there is an Error or Warning present. • Current power Displays the power currently being generated by the inverter. • Yield Displays the energy yield of the inverter. • Grid supply Displays the energy supply from the utility grid. • Power at the grid connection point Indicates which power is currently fed in or obtained at the grid-connection point.

11.5 Access rights to the user interface

An installer is created during registration. As an installer, you can add additional users to the system by defining and sharing a user password.

This gives users access to the system and to the devices recorded in the system.

The following rights are available on the user interface:

- User
- Installer
- Service

11.6 Logging into the user interface for the first time

i Installer password for inverters registered in a System Manager or in Sunny Portal

To be able to register the inverter in a System Manager (e.g. SMA Data Manager) or in a Sunny Portal system, the password for the user group **Installer** must match the system password. If you assign a password for the user group **Installer** via the user interface of the inverter, the same password must also be used as the system password.

- Assign a uniform installer password to all SMA devices in the system.

Procedure:

1. In the drop-down list **Language**, select the desired language.
 2. In the **Password** field, enter a password for the **User** user group.
 3. In the **Repeat password** field, enter the password again.
 4. Click on **Save**.
 5. In the **New password** field, enter a password for the **Installer** user group. Assign a uniform password to all SMA devices to be registered in a system. The installer password is also the system password.
 6. In the **Repeat password** field, enter the password again.
 7. Click on **Save and log in**.
- The **Configuring the Inverter** page opens.

Also see:

- [Establishing a Direct Connection via Ethernet](#) ⇒ page 59
- [Establishing a Connection via Ethernet in the local network](#) ⇒ page 61

11.7 Creating a user password

1. Follow the procedure for changing the parameters.
2. In the parameter group **User rights > Access control**, select the parameter **Set user password**.
3. Create a user password.
4. Select [**Save all**] to save the changes.

Also see:

- [Changing parameters](#) ⇒ page 68

11.8 Logging Into the User Interface

Requirement:

- A connection to the user interface of the inverter has been established and the login page is open.

Procedure:

1. In the drop-down list **Language**, select the desired language.
 2. Select the desired user group in the drop-down list **User group**.
 3. Enter the password in the field **Password**.
 4. Select **Login**.
- The start page of the user interface opens.

11.9 Logging out of the user interface

Requirement:

- You are logged in on the user interface as **User** or **Installer**.

Procedure:

1. On the right-hand side of the menu bar, select the menu **User Settings**.
 2. In the subsequent context menu, select [**Logout**].
- The login page of the user interface opens. The logout was successful.

11.10 Starting the Installation Assistant

QUALIFIED PERSON

The installation assistant guides you step-by-step through the initial configuration of the product.

Requirements:

- You must be logged in on the user interface as **Installer**.
- The inverter must be updated to the latest firmware version.

Procedure:

1. Select the menu **User settings** on the home page of the user interface.
 2. In the context menu, select [**Starting the installation assistant**].
- The installation assistant will open.

Also see:

- [Layout of the installation assistant](#) ⇒ page 63

11.11 Changing parameters

The parameters of the product are set to certain values by default. You can change the parameters to optimize the performance of the product.

This section describes the basic procedure for changing parameters. Always change parameters as described in this section.

Accepting the settings

Saving the made settings is indicated by an hourglass symbol on the user interface. If the DC voltage is sufficient, the data is transferred directly to the inverter and accepted. If the DC voltage is too low (e. g. in the evening), the settings are saved, but they cannot be directly transferred to or accepted by the inverter. As long as the inverter has not yet received and accepted the settings, the hourglass symbol will continue to be displayed on the user interface. The settings will be accepted when there is sufficient DC voltage applied and the inverter restarts. As soon as the hourglass symbol appears on the user interface, the settings have been saved. The settings will not be lost. You can log off of the user interface and leave the system.

Requirements:

- You are logged in on the user interface.
- Changes to grid-relevant parameters must be approved by the responsible grid operator.

Procedure:

1. Call up the menu **Device parameters**.
 2. Click on [**Edit parameters**].
 3. Expand the parameter group that contains the parameter which is to be configured.
 4. Change the required parameters.
 5. Select [**Save all**] to save the changes.
- The parameters are set.

Also see:

- [Establishing a Connection to the User Interface](#) ⇒ page 59

11.12 Activating the WPS Function

Requirements:

- WLAN must be activated in the product.
- WPS must be activated on the router.

Procedure:

1. Open the user interface (see Section 11.1, page 59).
 2. Log in as **Installer**.
 3. Start the installation assistant **Starting the Installation Assistant**.
 4. Select **Network configuration**.
 5. Select **WPS for WLAN network** button in the **WLAN** tab.
 6. Select **Activate WPS**.
 7. Select **Save and next** and exit the installation assistant.
- The WPS function is activated and the automatic connection to the network can be established.

11.13 Switching WLAN Off

If you would like to switch the WLAN function off completely, you must switch off both the direct connection and the connection in the local network.

Procedure:

- To switch off the direct connection in the parameter group **PV system communication > Wi-Fi**, select the parameter **Soft-access-point is turned on** and set this to **No**.
- To switch off the connection in the local network in the parameter group **PV system communication > WLAN**, select the parameter **WLAN is turned on** and set this to **No**.

11.14 Switching WLAN On

If you have switched the WLAN function for direct connection or for connection in the local network off, you can switch the WLAN function back on in accordance with the following procedure.

Requirements:

- If the WLAN function was previously switched off completely, the inverter must be connected to a computer or router via Ethernet.

Procedure:

- To switch on the WLAN direct connection, in the parameter group **PV system communication > WLAN**, select the parameter **Soft-access-point is turned on** and set this to **Yes**.
- To switch on the WLAN connection in the local network, in the parameter group **System communication > WLAN**, select the parameter **WLAN is turned on** and set this to **Yes**.

11.15 Configuring the active power mode for systems with external setpoint

QUALIFIED PERSON

Requirement:

- Installation assistant has been started.

Procedure:

1. Select [**Save and continue**] after each step up until the step **Grid management service**.
2. In the tab **Active power mode** set the switch **Active power setpoint** to [**On**].

3. In the drop-down list **Operating mode active power setpoint**, select the entry **External setpoint**.
4. In the drop-down list **Fallback behavior**, select the entry **Apply fallback values**.
5. In the **Fallback value of maximum active power** field, enter the value to which the product should limit its nominal power if communication to the higher-level control unit fails after the timeout time has elapsed.
6. In the **Timeout** field, enter the time that the product should wait until it limits its nominal power to the set fallback value.
7. If, in the event of a 0% or 0 W specification, the inverter is not permitted to feed small amounts of active power into the utility grid, select the entry **Yes** in the drop-down list **Grid disconnection for 0% active power setting**. This ensures that in the event of a 0% or 0 W specification, the inverter disconnects from the utility grid and does not feed in active power.

11.16 Configuring the active power mode for systems with manual setpoint

QUALIFIED PERSON

Requirement:

- Installation assistant has been started.

Procedure:

1. Select [**Save and continue**] after each step up until the step **Grid management service**.
2. In the tab **Active power mode** set the switch **Grid connection point regulation** to [**On**].
3. Enter the total power of the PV array in the field **Nominal system power**.
4. In the drop-down list **Operating mode of active power limitation at the point of interconnection**, select whether active power limitation is to be performed via a fixed specification in percent or in watts.
5. In the field **Set active power limit at the grid-connection point**, enter the value to which the active power at the grid-connection point is to be limited. The value must be set to **0** for zero power output.
6. Set the **Active power setpoint** to [**On**].
 - You can manually specify the active power or have the active power controlled by the inverter.
7. Manual preset: In the **Operating mode active power setting** drop-down list, select **Manual setting in %** or **Manual setting in W**.
8. Manual preset: Enter the default value in the **Active power** field.
9. Preset by inverter: In the drop-down list **Operating mode active power setpoint**, select the entry **External setting**.
10. Preset by inverter: In the drop-down list **Fallback behavior**, select the entry **Apply fallback values**.
11. Preset by inverter: In the drop-down list **Grid disconnection for 0% active power setting** select the entry **No**.

11.17 Arc-Fault Circuit Interrupter (AFCI)

QUALIFIED PERSON

The arc fault circuit interrupter (AFCI) can be activated with immediate operation inhibition, activated without operation inhibition or activated with operation inhibition after 5 detections within 24 hours.

You can set the arc-fault circuit interrupter using the following parameters.

Name	Group	Settings
AFCI	Device > Inverter	Yes No

You can use the following parameters to set the manual restart after an arc fault detection.

Name	Group	Settings	Explanation
Manual restart after arc detection	AC Side > Operation > Manual restart	On	After detecting an electric arc, the inverter interrupts the grid feed-in. The inverter remains in this state (operation inhibited) until the operating mode is manually set to Start .
		Off	After detecting an electric arc, the inverter interrupts the feed-in operation, disconnects from the utility grid, and automatically resumes operation after approximately 10 minutes. If an electric arc is still detected, the inverter disconnects again, and the process restarts.
		Yes, after 5 electric arc detections within 24 hrs (recommended)	After detecting an electric arc, the inverter interrupts the feed-in operation, disconnects from the utility grid, and automatically resumes operation after approximately 10 minutes. If an electric arc is still detected, the inverter disconnects again, and the process restarts. After 5 electric arc detections within 24 hours, the inverter remains in operation inhibition and must be manually reset to Start .

Inverters with arc-fault circuit interrupter (AFCI) without operation inhibition should be monitored regularly. Recurring electric arcs should promptly be inspected and rectified by qualified persons. If it is not possible to inspect and rectify the fault immediately, the inverter should be decommissioned until the cause of the fault has been clarified and rectified. Recurring electric arcs can damage the connection cables and the system components. Failures can occur. Uncontrolled electric arcs can also cause a fire.

You can use the following parameters to resume operation after an operating interruption.

Name	Group	Settings
General operating mode	Device > Operation	Start Stop

Also see:

- [Arc-Fault Circuit Interrupter \(AFCI\) ⇒ page 20](#)
- [Changing parameters ⇒ page 68](#)

11.18 Generating a product key for the first time

If you have forgotten the product's password, you can use the product key to create a new one. The product key is stored only on the device. A lost product key cannot be recovered, it can only be recreated.

Creating a product key is not mandatory, but is recommended by because the product key significantly increases the security of the system. A product key must be generated for each of the user groups **User** and **Installer**.

Requirements:

- The user interface is open and you are logged in as **User** or **Installer**.

Procedure:

1. Select the menu **User settings**.
2. Select [**Access rights**].
3. Select [**Product key**].
4. Enter the specific device secret of the product. Which specific device secret is used and where you can find the specific device secret is indicated on the user interface.
5. Click on [**Generate**].
 - A string representing the product key is generated.
6. Write down the product key immediately and keep it safe. After leaving this page, the newly generated product key can no longer be displayed. The copy of the product key must be accessible only to you.

Also see:

- [Establishing a Connection to the User Interface ⇒ page 59](#)
- [Logging Into the User Interface ⇒ page 67](#)

11.19 Generate new product key

If the product key has become accessible to unauthorized persons, you can generate a new product key at any time.

Requirements:

- The currently valid product key must be available.
- The user interface is open and you are logged in as **User** or **Installer**.

Procedure:

1. Select the menu **User settings**.
2. Select [**Access rights**].
3. Select [**Product key**].
4. Enter the currently valid product key.
5. Click on [**Generate**].
 - A string representing the new product key is generated.
6. Write down the new product key immediately and keep it safe. After leaving this page, the newly generated product key can no longer be displayed. The previously valid product key is invalid after a new product key is generated. The copy of the product key must be accessible only to you.

Also see:

- [Establishing a Connection to the User Interface ⇒ page 59](#)
- [Logging Into the User Interface ⇒ page 67](#)

11.20 Activate Service access

In the event of a malfunction of the product, it may be necessary for a service user authorized by to access the user interface of the product.

Service access must be activated to execute warranty services. If a quick and uncomplicated service intervention is to be enabled in an emergency, the service access must be permanently activated.

You have the option of activating the service access permanently or for a certain period of time.

Requirements:

- The user interface is open and you are logged in as **User** or **Installer**.

Procedure:

1. Select the menu **User settings**.
2. Select [**Access rights**].
3. Select [**Service**].
4. To activate service access permanently, click on [**Yes, permanently**] in the drop-down list.
5. To enable service access for a specific time, click on [**Yes, temporary**] in the drop-down list and adjust the expiration date if necessary.
6. Click on [**Save**].

Also see:

- [Establishing a Connection to the User Interface](#) ⇒ page 59
- [Logging Into the User Interface](#) ⇒ page 67

11.21 Deactivate Service access

Requirements:

- The user interface is open and you are logged in as **User** or **Installer**.

Procedure:

1. Select the menu **User settings**.
2. Select [**Access rights**].
3. Select [**Service**].
4. In the drop-down list select the entry [**No**].
5. Click on [**Save**].

Also see:

- [Establishing a Connection to the User Interface](#) ⇒ page 59
- [Logging Into the User Interface](#) ⇒ page 67

11.22 Password

The password for the product can be changed for both user groups. Furthermore, the user group **Installer** can change the password for the user group **User** as well as their own password.

Channel	Name	Group	Settings
Acs.Pwdlstl	Set user password	User Rights > Access Control	<ul style="list-style-type: none"> • Random password according to password guideline
Acs.Pwdlstl	Set installer password	User Rights > Access Control	<ul style="list-style-type: none"> • Random password according to password guideline

11.23 Dynamic power display (green LED)

As standard, the product signals its power dynamically via the pulsing of the green LED. When doing so, the LED flashes on and off uniformly or is permanently lit at full power. The various gradations are related here to the set active power limit of the product.

You can deactivate the dynamic power display. In this case, the green LED is lit permanently in feed-in operation.

Channel	Name	Group	Settings
Operation.GrnlEdWInd	Dynamic power display via green LED	Device > Operation	<ul style="list-style-type: none"> • On (standard) • Off

Also see:

- [Logging Into the User Interface](#) ⇒ page 67

11.24 Q on Demand 24/7

The general setting of the grid management services (e.g. cos phi setpoint or Q(V) characteristic curve) can not be fully set independently of the "Q on Demand 24/7" function via the relevant parameters - "Q on Demand 24/7" only permits Q specifications. It is to be noted here that certain settings can have an influence on other grid-support settings and functions.

This means that if the "Q on Demand 24/7" function" is active, no other grid-supporting functions (e.g., cos phi) are possible between day and night operation of the inverter. Should an independent reactive power provision be desired between day- and night operation, the reactive power provision must be communicated to the inverter via a superordinate control unit.

The function "Q on Demand 24/7" is not compatible with the reactive power modes **cos φ(P) charac. curve** or **cos φ(V) charac. curve**.

Currently, the provision of reactive power can only be read off via the phase currents and phase voltages in the instantaneous values (**Realtime values > AC Side > Phase currents / Phase voltage**) or requested via Modbus.

You can set the reactive power mode using the following parameters.

Channel	Name	Group	Settings
Inverter.VAr-ModCfg.VAr-ModOutFlb	Reactive power fallback process in case of active power output	System and device control > Inverter > Reactive power mode	Selection of various reactive power modes
Inverter.VAr-ModCfg.VAr-ModZerW	Reactive power for zero active power	System and device control > Inverter > Reactive power mode	Selection of various reactive power modes

11.25 Saving the Configuration in a File

You can save the current configuration of the product to a file. To configure the products, you can use this file as a backup of this product and then import the file back into this product or other products of the same type or device family. When saving, only the device parameters will be saved, not any passwords.

Prerequisite:

- You are logged in on the user interface.

Procedure:

1. Select the menu **Device Configuration**.
2. Select [**Settings**].
3. In the context menu, select [**Saving the configuration in a file**].
4. Follow the instructions in the dialog.

Also see:

- [Adopting a Configuration from a File](#) ⇒ page 75

11.26 Adopting a Configuration from a File

QUALIFIED PERSON

To configure the product, you can transfer the configuration from a file. To do this, you must first save the configuration of another product of the same type or the same device family to a file. When saving, only the device parameters will be adopted, not any passwords.

Requirements:

- Changes to grid-relevant parameters must be approved by the responsible grid operator.
- You are logged in on the user interface as **Installer**.

Procedure:

1. Select the menu **Device Configuration**.
2. Select [**Settings**].
3. In the context menu, select [**Adopting the configuration from a file**].
4. Follow the instructions in the dialog.

Also see:

- [Saving the Configuration in a File ⇒ page 74](#)

11.27 Configuring the Country Data Set

For the product to begin operation, a country data set must be set (for instance via the installation assistant on the user interface of the product, or via a communication product). As long as no country data set is set, operation of the product will remain stopped. This state is signaled by the green and red LEDs flashing simultaneously. Once configuration of the product is completed, the product will start operating automatically.

The country data set must be set correctly.

If you select a country data set which is not valid for your country and purpose, it can cause a disturbance in the PV system and lead to problems with the grid operator. When selecting the country data set, you must always observe the locally applicable standards and directives as well as the properties of the PV system (e.g. PV system size, grid-connection point).

- If you are not sure which standards and directives are valid for your country or purpose, contact the grid operator.

Procedure:

1. Follow the procedure for changing the parameters.
2. In the parameter group **Grid monitoring > Grid monitoring**, select the parameter **Set country data set**.
3. Configure the required country data set.
4. Select [**Save all**] to save the changes.

11.28 Automatic firmware update

The product can automatically download and install a firmware update. You can activate the automatic firmware update either via the user interface of the product or the System Manager (e.g. SMA Data Manager) or via the Sunny Portal.

If the automatic firmware updated is deactivated, you can manually search and install new firmware versions.

You can activate or deactivate the automatic firmware update using the following parameter.

Channel	Name	Group	Settings
Upd.AutoUpd- sOn	Automatic updates activated	Device > Update	<ul style="list-style-type: none"> • Yes • No (standard)

Also see:

- [Updating firmware via the user interface ⇒ page 76](#)

11.29 Updating firmware via the user interface

QUALIFIED PERSON

Requirements:

- The product must be connected to the Internet.
- You are logged in on the user interface as **Installer**.

Procedure:

1. Select the menu **Device Parameters**.
 2. Click on **[Edit parameters]**.
 3. Select **Device > Update**.
 4. Select the parameter **Check for update and install it** and set it to **Execute**.
 5. Click on **[Save all]**.
- The firmware is updated in the background.

11.30 Operating Modes of the Multifunction Relay

You can use the following parameters to set the operating mode of the multifunction relay.

Name	Group	Settings
Operating mode of multifunction relay	Device>Multifunction relay	<ul style="list-style-type: none"> • Off • Fan control • Switching status grid relay • Control via communication • Fault indication

The setting values for the operating mode of the multifunction relay are to be understood as follows:

Settings	Description
Fan control	The multifunction relay controls an external fan, depending on the temperature of the inverter.
Switching status grid relay	The local grid operator may require that a signal is transmitted as soon as the inverter connects to the utility grid. The multifunction relay can be used to trigger this signal.

Settings	Description
Control via communication	The multifunction relay switches loads on or off according to commands transmitted by a communication product.
Fault indication	The multifunction relay controls a display device (e.g. a warning light) which, depending on the type of connection, signals either an error or the undisturbed operation of the inverter.

Also see:

- [Changing the Operating Mode of the Multifunction Relay](#) ⇒ page 77

11.31 Changing the Operating Mode of the Multifunction Relay

The default operating mode of the multifunction relay is **Fault indication**. If you decide to use another operating mode and have established the correct electrical connection for this operating mode and the associated connection variant, you will have to change the operating mode of the multifunction relay and make other settings, if necessary.

Procedure:

1. Follow the procedure for changing the parameters.
2. In the parameter group **Device>Multifunction relay**, select the parameter **Operating mode of multifunction relay** and set the required operating mode.
3. Select [**Save all**] to save the changes.

Also see:

- [Establishing a Connection to the User Interface](#) ⇒ page 59

11.32 Setting the fast-stop function with external switch

After selecting a function and completing the necessary electrical connection, you must activate the fast-stop parameters and, if required, configure additional settings.

The setting can be activated in the installation assistant under the step **Grid management services > Enable fast-stop function**.

Procedure:

1. Follow the procedure for changing the parameters.
2. In the parameter group **Device > Inputs/outputs > Digital input**, select the parameter **Fast shutdown via the digital input** and set it to **Yes**.
3. Select [**Save all**] to save the changes.

Also see:

- [Changing parameters](#) ⇒ page 68
- [Starting the Installation Assistant](#) ⇒ page 68

11.33 Configuring the fast stop for the external grid and PV system protection function

After selecting a function and completing the appropriate electrical connection, you must activate the parameters for grid and PV system protection and, if required, configure additional settings.

The setting can be activated in the installation assistant under the step **Grid management services > Enable grid and PV system protection via I/O modules**.

Procedure:

1. Follow the procedure for changing the parameters.

2. In the parameter group **Device > Power control module**, select the parameter **Grid and system protection** and set it to **On**.
3. Select [**Save all**] to save the changes.

Also see:

- [Changing parameters](#) ⇒ page 68
- [Starting the Installation Assistant](#) ⇒ page 68

11.34 Setting SMA ShadeFix

You can set the time interval in which the inverter has to determine the optimum operating point and to optimize the MPP of the PV system. In battery-backup operation mode, SMA ShadeFix is automatically deactivated.

Procedure:

1. Follow the procedure for changing the parameters [Changing parameters](#).
2. In the parameter group **DC-side > DC settings > SMA ShadeFix**, set the parameter **Time interval of SMA ShadeFix** and set the required time interval.
3. Set the desired time interval. The ideal time interval is usually six minutes. This value should only be increased if the shading situation changes extremely slowly.

12 Disconnecting the Inverter from Voltage Sources

⚠ QUALIFIED PERSON

Prior to performing any work on the inverter, always disconnect it from all voltage sources as described in this section. Adhere to the prescribed sequence.

⚠ WARNING

Danger to life due to electric shock from destruction of the measuring device due to overvoltage

Overvoltage can damage a measuring device and result in voltage being present in the enclosure of the measuring device. Touching the live enclosure of the measuring device results in death or lethal injuries due to electric shock.

- Only use measuring devices with a measurement ranges designed for the maximum AC and DC voltage of the inverter.

Procedure:

1. Shut down the AC voltage supply and secure against unintentional reconnection.
2. Switch off all 3 DC load-break switches of the inverter and secure against reconnection.

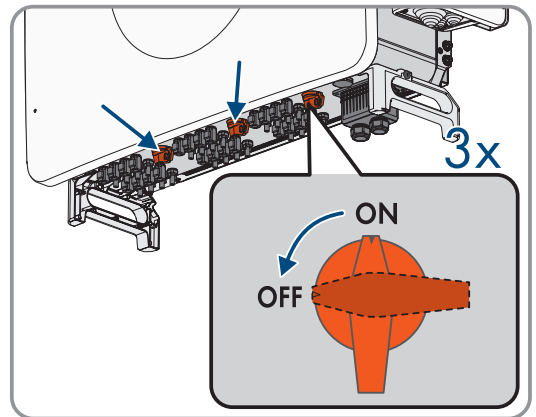

3. Wait until the LEDs have gone out.
4. Use a current clamp to ensure that no current is present in the DC cables.

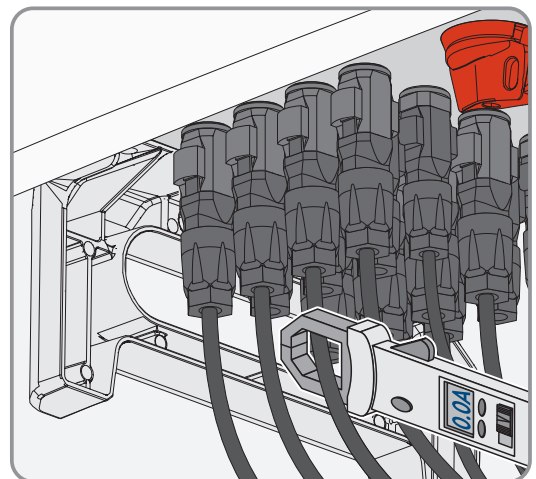

5. Note the position of the DC connectors.

6.

⚠ DANGER**Danger to life due to electric shock when touching exposed DC conductors or DC plug contacts if the DC connectors are damaged or loose**

The DC connectors can break or become damaged, become free of the DC cables, or no longer be connected correctly if the DC connectors are released and disconnected incorrectly. This can result in the DC conductors or DC plug contacts being exposed. Touching live DC conductors or DC plug connectors will result in death or serious injury due to electric shock.

- Wear insulated gloves and use insulated tools when working on the DC connectors.
- Ensure that the DC connectors are in perfect condition and that none of the DC conductors or DC plug contacts are exposed.
- Carefully release and remove the DC connectors as described in the following.

7. Unlock the DC connector using the corresponding unlocking tool and remove (refer to the manufacturer manual for further information).

8. Ensure that the DC connectors on the product and those that are equipped with DC conductors are in perfect condition and that none of the DC conductors or DC plug contacts are exposed.

9. Ensure that no voltage is present at the DC inputs on the inverter using a suitable voltage detector.

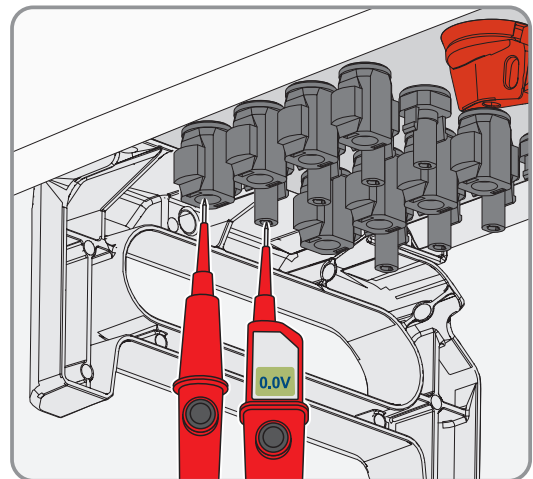

10.

⚠ DANGER**Danger to life due to high voltages**

Even after disconnection, there are residual voltages on the product that must be removed.

- Wait 5 minutes before proceeding.

11. Check that there is no voltage at the AC connection between L1 and L2, L2 and L3, L1 and L3 and L1 and grounding conductor, L2 and grounding conductor, L3 and grounding conductor and between L1 and N, L2 and N and L3 and N using a suitable voltage detector. For this purpose, hold the test prods to the conductors' ring terminal lugs.

13 Troubleshooting

13.1 Overview of the designations for MPP trackers

The designations of the MPP trackers on the product user interface differ from the labeling on the product. In case of failure, observe the following table for troubleshooting:

Designation on the product	Designations on the user interface
MPPT-1	MPPT-A
MPPT-2	MPPT-B
MPPT-3	MPPT-C
MPPT-4	MPPT-D
MPPT-5	MPPT-E
MPPT-6	MPPT-F
MPPT-7	MPPT-G
MPPT-8	MPPT-H
MPPT-9	MPPT-I
MPPT-10	MPPT-J
MPPT-11	MPPT-K
MPPT-12	MPPT-L

13.2 Event messages

13.2.1 Event 102

QUALIFIED PERSON

Event message:

- Grid incident

Explanation:

The grid voltage or grid impedance at the connection point of the inverter is too high. The inverter has disconnected from the utility grid.

Corrective measures:

- Check whether the grid voltage at the connection point of the inverter is permanently in the permissible range. If the grid voltage is outside the permissible range due to local grid conditions, contact the grid operator. The grid operator must agree with an adjustment of the voltage at the feed-in point or with a change of the monitored operating limits.
If the grid voltage is permanently within the permissible range and this message is still displayed, contact the Service.

13.2.2 Event 103

QUALIFIED PERSON

Event message:

- **Grid incident**

Explanation:

The grid voltage or grid impedance at the connection point of the inverter is too high. The inverter has disconnected from the utility grid.

Corrective measures:

- Check whether the grid voltage at the connection point of the inverter is permanently in the permissible range. If the grid voltage is outside the permissible range due to local grid conditions, contact the grid operator. The grid operator must agree with an adjustment of the voltage at the feed-in point or with a change of the monitored operating limits.
If the grid voltage is permanently within the permissible range and this message is still displayed, contact the Service.

13.2.3 Event 203

QUALIFIED PERSON

Event message:

- **Grid incident**

Explanation:

The utility grid has been disconnected, the AC cable is damaged or the grid voltage at the connection point of the inverter is too low. The inverter has disconnected from the utility grid.

Corrective measures:

- Ensure that the miniature circuit breaker is switched on.
- Ensure that the AC cable is not damaged and that it is connected correctly.
- Ensure that the country data set has been configured correctly.
- Check whether the grid voltage at the connection point of the inverter is permanently in the permissible range. If the grid voltage is outside the permissible range due to local grid conditions, contact the grid operator. The grid operator must agree with an adjustment of the voltage at the feed-in point or with a change of the monitored operating limits.
If the grid voltage is permanently within the permissible range and this message is still displayed, contact the Service.

13.2.4 Event 502

QUALIFIED PERSON

Event message:

- **Grid incident**

Explanation:

The grid frequency is not within the permissible range. The inverter has disconnected from the utility grid.

Corrective measures:

- If possible, check the grid frequency and observe how often fluctuations occur.
If fluctuations occur frequently and this message is displayed often, contact the grid operator and request approval to change the operating parameters of the inverter.
If the grid operator gives approval, discuss any changes to the operating parameters with the Service.

13.2.5 Event 503**⚠ QUALIFIED PERSON****Event message:**

- **Grid incident**

Explanation:

The grid frequency is not within the permissible range. The inverter has disconnected from the utility grid.

Corrective measures:

- If possible, check the grid frequency and observe how often fluctuations occur.
If fluctuations occur frequently and this message is displayed often, contact the grid operator and request approval to change the operating parameters of the inverter.
If the grid operator gives approval, discuss any changes to the operating parameters with the Service.

13.2.6 Event 601**⚠ QUALIFIED PERSON****Event message:**

- **Grid incident**

Explanation:

The inverter has detected an excessively high proportion of direct current in the grid current.

Corrective measures:

- Check the grid connection for direct current.
- If this message is displayed frequently, contact the grid operator and check whether the monitoring threshold on the inverter can be raised.

13.2.7 Event 901**⚠ QUALIFIED PERSON****Event message:**

- **PE connection missing**
- **Check connection**

Explanation:

The grounding conductor is not correctly connected.

Corrective measures:

- Ensure that the grounding conductor is correctly connected.

13.2.8 Event 1302

QUALIFIED PERSON

Event message:

- **Waiting for grid voltage**
- **Grid connection installation failure**
- **Check grid and fuses**

Explanation:

Either L or N is not connected, or the utility grid has failed.

Corrective measures:

- Ensure that there is no utility grid failure.
- Ensure that the line conductors are connected.
- Ensure that the miniature circuit breaker is switched on.
- Ensure that the AC cable is not damaged and that it is connected correctly.

13.2.9 Event 1416

QUALIFIED PERSON

Event message:

- Grid incident

Explanation:

Due to a voltage imbalance between the line conductors, the system disconnects from the utility grid.

Corrective measures:

- Eliminate any faults in the installation.

13.2.10 Event 1501

QUALIFIED PERSON

Event message:

- **Reconnection fault grid**

Explanation:

The changed country standard or the value of a parameter you have set does not correspond to the local requirements. The inverter cannot connect to the utility grid.

Corrective measures:

- Ensure that the country data set has been configured correctly. To do this, select the parameter **Set country standard** and check the value.

13.2.11 Event 3401

QUALIFIED PERSON

Event message:

- **DC overvoltage**
- **Disconnect generator**

Explanation:

Overvoltage at the DC input. This can destroy the inverter.

This message is signaled additionally by rapid flashing of the LEDs.

Corrective measures:

- **Immediately** disconnect the inverter from voltage sources and secure it against being switched on again.
- Check whether the DC voltage is below the maximum input voltage of the inverter. If the DC voltage is below the maximum input voltage of the inverter, reconnect the DC cables to the inverter.
- If the DC voltage exceeds the maximum input voltage of the inverter, ensure that the PV array has been correctly rated or contact the installer of the PV array.
- If this message is repeated frequently, contact the Service.

13.2.12 Event 3402**⚠ QUALIFIED PERSON****Event message:**

- **DC overvoltage**
- **Disconnect generator**

Explanation:

Overvoltage at the DC input. This can destroy the inverter.

This message is signaled additionally by rapid flashing of the LEDs.

Corrective measures:

- **Immediately** disconnect the inverter from voltage sources and secure it against being switched on again.
- Check whether the DC voltage is below the maximum input voltage of the inverter. If the DC voltage is below the maximum input voltage of the inverter, reconnect the DC cables to the inverter.
- If the DC voltage exceeds the maximum input voltage of the inverter, ensure that the PV array has been correctly rated or contact the installer of the PV array.
- If this message is repeated frequently, contact the Service.

13.2.13 Event 3407**⚠ QUALIFIED PERSON****Event message:**

- **DC overvoltage**
- **Disconnect generator**

Explanation:

Overvoltage at the DC input. This can destroy the inverter.

This message is signaled additionally by rapid flashing of the LEDs.

Corrective measures:

- **Immediately** disconnect the inverter from voltage sources and secure it against being switched on again.
- Check whether the DC voltage is below the maximum input voltage of the inverter. If the DC voltage is below the maximum input voltage of the inverter, reconnect the DC cables to the inverter.
- If the DC voltage exceeds the maximum input voltage of the inverter, ensure that the PV array has been correctly rated or contact the installer of the PV array.

- If this message is repeated frequently, contact the Service.

13.2.14 Event 3410

QUALIFIED PERSON

Event message:

- **DC overvoltage**
- **Disconnect generator**

Explanation:

Overvoltage at the DC input. This can destroy the inverter.

This message is signalized additionally by rapid flashing of the LEDs.

Corrective measures:

- **Immediately** disconnect the inverter from voltage sources and secure it against being switched on again.
- Check whether the DC voltage is below the maximum input voltage of the inverter. If the DC voltage is below the maximum input voltage of the inverter, reconnect the DC cables to the inverter.
- If the DC voltage exceeds the maximum input voltage of the inverter, ensure that the PV array has been correctly rated or contact the installer of the PV array.
- If this message is repeated frequently, contact the Service.

13.2.15 Event 3411

QUALIFIED PERSON

Event message:

- **DC overvoltage**
- **Disconnect generator**

Explanation:

Overvoltage at the DC input. This can destroy the inverter.

This message is signalized additionally by rapid flashing of the LEDs.

Corrective measures:

- **Immediately** disconnect the inverter from voltage sources and secure it against being switched on again.
- Check whether the DC voltage is below the maximum input voltage of the inverter. If the DC voltage is below the maximum input voltage of the inverter, reconnect the DC cables to the inverter.
- If the DC voltage exceeds the maximum input voltage of the inverter, ensure that the PV array has been correctly rated or contact the installer of the PV array.
- If this message is repeated frequently, contact the Service.

13.2.16 Event 3412

QUALIFIED PERSON

Event message:

- DC overvoltage
- Disconnecting generator

Explanation:

Overvoltage at the DC input. This can destroy the inverter.

This message is signaled additionally by rapid flashing of the LEDs.

Corrective measures:

- **Immediately** disconnect the inverter from voltage sources and secure it against being switched on again.
- Check whether the DC voltage is below the maximum input voltage of the inverter. If the DC voltage is below the maximum input voltage of the inverter, reconnect the DC cables to the inverter.
- If the DC voltage exceeds the maximum input voltage of the inverter, ensure that the PV array has been correctly rated or contact the installer of the PV array.
- If this message is repeated frequently, contact the Service.

13.2.17 Event 3413**⚠ QUALIFIED PERSON****Event message:**

- DC overvoltage
- Disconnecting generator

Explanation:

Overvoltage at the DC input. This can destroy the inverter.

This message is signaled additionally by rapid flashing of the LEDs.

Corrective measures:

- **Immediately** disconnect the inverter from voltage sources and secure it against being switched on again.
- Check whether the DC voltage is below the maximum input voltage of the inverter. If the DC voltage is below the maximum input voltage of the inverter, reconnect the DC cables to the inverter.
- If the DC voltage exceeds the maximum input voltage of the inverter, ensure that the PV array has been correctly rated or contact the installer of the PV array.
- If this message is repeated frequently, contact the Service.

13.2.18 Event 3414**⚠ QUALIFIED PERSON****Event message:**

- DC overvoltage
- Disconnecting generator

Explanation:

Overvoltage at the DC input. This can destroy the inverter.

This message is signaled additionally by rapid flashing of the LEDs.

Corrective measures:

- **Immediately** disconnect the inverter from voltage sources and secure it against being switched on again.
- Check whether the DC voltage is below the maximum input voltage of the inverter. If the DC voltage is below the maximum input voltage of the inverter, reconnect the DC cables to the inverter.
- If the DC voltage exceeds the maximum input voltage of the inverter, ensure that the PV array has been correctly rated or contact the installer of the PV array.

- If this message is repeated frequently, contact the Service.

13.2.19 Event 3415

QUALIFIED PERSON

Event message:

- DC overvoltage
- Disconnecting generator

Explanation:

Overvoltage at the DC input. This can destroy the inverter.

This message is signalized additionally by rapid flashing of the LEDs.

Corrective measures:

- **Immediately** disconnect the inverter from voltage sources and secure it against being switched on again.
- Check whether the DC voltage is below the maximum input voltage of the inverter. If the DC voltage is below the maximum input voltage of the inverter, reconnect the DC cables to the inverter.
- If the DC voltage exceeds the maximum input voltage of the inverter, ensure that the PV array has been correctly rated or contact the installer of the PV array.
- If this message is repeated frequently, contact the Service.

13.2.20 Event 3416

QUALIFIED PERSON

Event message:

- DC overvoltage
- Disconnecting generator

Explanation:

Overvoltage at the DC input. This can destroy the inverter.

This message is signalized additionally by rapid flashing of the LEDs.

Corrective measures:

- **Immediately** disconnect the inverter from voltage sources and secure it against being switched on again.
- Check whether the DC voltage is below the maximum input voltage of the inverter. If the DC voltage is below the maximum input voltage of the inverter, reconnect the DC cables to the inverter.
- If the DC voltage exceeds the maximum input voltage of the inverter, ensure that the PV array has been correctly rated or contact the installer of the PV array.
- If this message is repeated frequently, contact the Service.

13.2.21 Event 3417

QUALIFIED PERSON

Event message:

- DC overvoltage
- Disconnecting generator

Explanation:

Overvoltage at the DC input. This can destroy the inverter.

This message is signaled additionally by rapid flashing of the LEDs.

Corrective measures:

- **Immediately** disconnect the inverter from voltage sources and secure it against being switched on again.
- Check whether the DC voltage is below the maximum input voltage of the inverter. If the DC voltage is below the maximum input voltage of the inverter, reconnect the DC cables to the inverter.
- If the DC voltage exceeds the maximum input voltage of the inverter, ensure that the PV array has been correctly rated or contact the installer of the PV array.
- If this message is repeated frequently, contact the Service.

13.2.22 Event 3418**⚠ QUALIFIED PERSON****Event message:**

- DC overvoltage
- Disconnecting generator

Explanation:

Overvoltage at the DC input. This can destroy the inverter.

This message is signaled additionally by rapid flashing of the LEDs.

Corrective measures:

- **Immediately** disconnect the inverter from voltage sources and secure it against being switched on again.
- Check whether the DC voltage is below the maximum input voltage of the inverter. If the DC voltage is below the maximum input voltage of the inverter, reconnect the DC cables to the inverter.
- If the DC voltage exceeds the maximum input voltage of the inverter, ensure that the PV array has been correctly rated or contact the installer of the PV array.
- If this message is repeated frequently, contact the Service.

13.2.23 Event 3501**⚠ QUALIFIED PERSON****Event message:**

- **Insulation failure**
- **Check generator**

Explanation:

The inverter has detected a ground fault in the PV module.

Corrective measures:

- Check the PV system for ground faults.

13.2.24 Event 3601

QUALIFIED PERSON

Event message:

- High discharge current
- Check generator

Explanation:

The leakage current of the inverter and the PV module is too high. There is a ground fault, a residual current or a malfunction.

The inverter interrupts feed-in operation immediately after exceeding a threshold. When the fault is eliminated, the inverter automatically reconnects to the utility grid.

Corrective measures:

- Check the PV system for ground faults.

13.2.25 Event 3800

QUALIFIED PERSON

Event message:

- Residual current too high
- Check generator

Explanation:

Overcurrent at the DC input. The inverter briefly interrupts feed-in operation.

Corrective measures:

- If this message is displayed frequently, ensure that the PV module has been correctly rated and wired.

13.2.26 Event 3804

QUALIFIED PERSON

Event message:

- Residual current too high
- Check generator

Explanation:

Overcurrent at the DC input. The inverter briefly interrupts feed-in operation.

Corrective measures:

- If this message is displayed frequently, ensure that the PV module has been correctly rated and wired.

13.2.27 Event 3901

QUALIFIED PERSON

Event message:

- Waiting for DC start conditions
- Start conditions not met

Explanation:

The feed-in conditions for the utility grid are not yet fulfilled.

Corrective measures:

- Ensure that the PV module is not covered by snow or otherwise shaded.
- Wait for higher irradiation.
- If this message is displayed frequently in the morning, increase the voltage limit for starting grid feed-in. Change the parameter **Critical voltage to start feed-in**.
- If this message is displayed frequently with medium irradiation, ensure that the PV module is correctly rated and wired.

13.2.28 Event 4002**⚠ QUALIFIED PERSON****Event message:**

- String [#] disturbance of the output current

Corrective measures:

- Check whether individual PV modules are heavily soiled or covered with snow.
- Ensure that the PV module shows no signs of abnormal aging.
- If the fault cannot be rectified using the indicated corrective measures, contact Service.

13.2.29 Event 4013**⚠ QUALIFIED PERSON****Event message:**

- Reverse currents or input X polarity reversed
- Check generator

Explanation:

The displayed input is in reverse polarity or reverse current has been detected in the input.

Corrective measures:

- Check the correct polarity of the connected PV modules.
- Ensure correct design and circuitry of the PV array.
- If solar irradiation is sufficient, check whether the same voltage is present at the DC inputs.
- Ensure that no PV module is defective.

13.2.30 Event 4014**⚠ QUALIFIED PERSON****Event message:**

- Reverse currents or input X polarity reversed
- Check generator

Explanation:

The displayed input is in reverse polarity or reverse current has been detected in the input.

Corrective measures:

- Check the correct polarity of the connected PV modules.
- Ensure correct design and circuitry of the PV array.
- If solar irradiation is sufficient, check whether the same voltage is present at the DC inputs.
- Ensure that no PV module is defective.

13.2.31 Event 4015**⚠ QUALIFIED PERSON****Event message:**

- Reverse currents or input X polarity reversed
- Check generator

Explanation:

The displayed input is in reverse polarity or reverse current has been detected in the input.

Corrective measures:

- Check the correct polarity of the connected PV modules.
- Ensure correct design and circuitry of the PV array.
- If solar irradiation is sufficient, check whether the same voltage is present at the DC inputs.
- Ensure that no PV module is defective.

13.2.32 Event 4016**⚠ QUALIFIED PERSON****Event message:**

- Reverse currents or input X polarity reversed
- Check generator

Explanation:

The displayed input is in reverse polarity or reverse current has been detected in the input.

Corrective measures:

- Check the correct polarity of the connected PV modules.
- Ensure correct design and circuitry of the PV array.
- If solar irradiation is sufficient, check whether the same voltage is present at the DC inputs.
- Ensure that no PV module is defective.

13.2.33 Event 4017**⚠ QUALIFIED PERSON****Event message:**

- Reverse currents or input X polarity reversed
- Check generator

Explanation:

The displayed input is in reverse polarity or reverse current has been detected in the input.

Corrective measures:

- Check the correct polarity of the connected PV modules.
- Ensure correct design and circuitry of the PV array.
- If solar irradiation is sufficient, check whether the same voltage is present at the DC inputs.
- Ensure that no PV module is defective.

13.2.34 Event 4018**⚠ QUALIFIED PERSON****Event message:**

- Reverse currents or input X polarity reversed
- Check generator

Explanation:

The displayed input is in reverse polarity or reverse current has been detected in the input.

Corrective measures:

- Check the correct polarity of the connected PV modules.
- Ensure correct design and circuitry of the PV array.
- If solar irradiation is sufficient, check whether the same voltage is present at the DC inputs.
- Ensure that no PV module is defective.

13.2.35 Event 4019**⚠ QUALIFIED PERSON****Event message:**

- Reverse currents or input X polarity reversed
- Check generator

Explanation:

The displayed input is in reverse polarity or reverse current has been detected in the input.

Corrective measures:

- Check the correct polarity of the connected PV modules.
- Ensure correct design and circuitry of the PV array.
- If solar irradiation is sufficient, check whether the same voltage is present at the DC inputs.
- Ensure that no PV module is defective.

13.2.36 Event 4020**⚠ QUALIFIED PERSON****Event message:**

- Reverse currents or input X polarity reversed
- Check generator

Explanation:

The displayed input is in reverse polarity or reverse current has been detected in the input.

Corrective measures:

- Check the correct polarity of the connected PV modules.
- Ensure correct design and circuitry of the PV array.
- If solar irradiation is sufficient, check whether the same voltage is present at the DC inputs.
- Ensure that no PV module is defective.

13.2.37 Event 4021**⚠ QUALIFIED PERSON****Event message:**

- Reverse currents or input X polarity reversed
- Check generator

Explanation:

The displayed input is in reverse polarity or reverse current has been detected in the input.

Corrective measures:

- Check the correct polarity of the connected PV modules.
- Ensure correct design and circuitry of the PV array.
- If solar irradiation is sufficient, check whether the same voltage is present at the DC inputs.
- Ensure that no PV module is defective.

13.2.38 Event 4022**⚠ QUALIFIED PERSON****Event message:**

- Reverse currents or input X polarity reversed
- Check generator

Explanation:

The displayed input is in reverse polarity or reverse current has been detected in the input.

Corrective measures:

- Check the correct polarity of the connected PV modules.
- Ensure correct design and circuitry of the PV array.
- If solar irradiation is sufficient, check whether the same voltage is present at the DC inputs.
- Ensure that no PV module is defective.

13.2.39 Event 4023**⚠ QUALIFIED PERSON****Event message:**

- Reverse currents or input X polarity reversed
- Check generator

Explanation:

The displayed input is in reverse polarity or reverse current has been detected in the input.

Corrective measures:

- Check the correct polarity of the connected PV modules.
- Ensure correct design and circuitry of the PV array.
- If solar irradiation is sufficient, check whether the same voltage is present at the DC inputs.
- Ensure that no PV module is defective.

13.2.40 Event 4024**⚠ QUALIFIED PERSON****Event message:**

- Reverse currents or input X polarity reversed
- Check generator

Explanation:

The displayed input is in reverse polarity or reverse current has been detected in the input.

Corrective measures:

- Check the correct polarity of the connected PV modules.
- Ensure correct design and circuitry of the PV array.
- If solar irradiation is sufficient, check whether the same voltage is present at the DC inputs.
- Ensure that no PV module is defective.

13.2.41 Event 4301**⚠ QUALIFIED PERSON****Event message:**

- **Serial el.arc in String |s0| detected by AFCI mod.**

Explanation:

The inverter has detected an electric arc in the displayed string. If "String N/A" is displayed, the string could not be uniquely assigned.

The inverter stops feeding into the utility grid.

Corrective measures:

- Disconnect the inverter from voltage sources and secure it against being switched on again.
- Check the PV modules and the cabling in the affected string or, if the string was not displayed, in all strings for damage.
- Ensure that the DC connection in the inverter is correct.
- Repair or replace defective PV modules, DC cables or the DC connection in the inverter.
- Start manual restart (if necessary).

13.2.42 Event 6001-6499**⚠ QUALIFIED PERSON****Event message:**

- **Self-diagnosis**
- **Interference device**

Explanation:

The cause must be determined by the Service.

Corrective measures:

- Contact Service.

13.2.43 Event 6501**⚠ QUALIFIED PERSON****Event message:**

- **Self-diagnosis**
- **Overtemperature**

Explanation:

The inverter has switched off due to excessive temperature.

Corrective measures:

- Clean the cooling fins on the rear of the enclosure and the air ducts on the top using a soft brush.
- Ensure that the inverter has sufficient ventilation.
- Ensure the maximum ambient temperature is not exceeded.

13.2.44 Event 6502**⚠ QUALIFIED PERSON****Event message:**

- **Self-diagnosis**
- **Overtemperature**

Explanation:

The inverter has switched off due to excessive temperature.

Corrective measures:

- Clean the cooling fins on the rear of the enclosure and the air ducts on the top using a soft brush.
- Ensure that the inverter has sufficient ventilation.
- Ensure that the maximum permissible ambient temperature is complied with.

13.2.45 Event 6509**⚠ QUALIFIED PERSON****Event message:**

- **Self-diagnosis**
- **Overtemperature**

Explanation:

The inverter has switched off due to excessive temperature.

Corrective measures:

- Clean the cooling fins on the rear of the enclosure and the air ducts on the top using a soft brush.
- Ensure that the inverter has sufficient ventilation.

- Ensure the maximum ambient temperature is not exceeded.

13.2.46 Event 6512

Event message:

- **Minimum operating temperature not reached**

Explanation:

The inverter will only recommence grid feed-in once the temperature has reached at least -25°C .

13.2.47 Event 6513

Event message:

- **Self-diagnosis**
- **Overtemperature**

Explanation:

The inverter has switched off due to excessive temperature.

Corrective measures:

- Ensure that the airflow is free of dirt.
- Ensure that the ambient temperature does not exceed the maximum permissible temperatures.
- If the maximum permissible temperature is met at all times and this message is displayed again, contact the Service.

13.2.48 Event 6603

QUALIFIED PERSON

Event message:

- **Self-diagnosis**
- **Overcurrent grid (HW)**

Explanation:

The cause must be determined by the Service.

Corrective measures:

- Contact Service.

13.2.49 Event 6604

QUALIFIED PERSON

Event message:

- **Self-diagnosis**
- **Overvoltage intermediate circuit (SW)**

Explanation:

The cause must be determined by the Service.

Corrective measures:

- Contact Service.

13.2.50 Event 6802

QUALIFIED PERSON

Event message:

- Self-diagnosis
- Input A defective

Explanation:

Polarity error on the inverter.

Corrective measures:

- Check whether a string is connected to input A.
- Contact Service.

13.2.51 Event 6902

QUALIFIED PERSON

Event message:

- Self-diagnosis
- Input B defective

Explanation:

Polarity error on the inverter.

Corrective measures:

- Check whether a string is connected to input B.
- Contact Service.

13.2.52 Event 7001

QUALIFIED PERSON

Event message:

- Fault sensor interior temperature

Explanation:

A temperature sensor in the inverter is defective and the inverter interrupts the feed-in operation. The cause must be determined by the Service.

Corrective measures:

- Contact Service.

13.2.53 Event 7002

QUALIFIED PERSON

Event message:

- Fault sensor interior temperature

Explanation:

A temperature sensor in the inverter is defective and the inverter interrupts the feed-in operation. The cause must be determined by the Service.

Corrective measures:

- Contact Service.

13.2.54 Event 7007**⚠ QUALIFIED PERSON****Event message:**

- Fault sensor interior temperature

Explanation:

A temperature sensor in the inverter is defective and the inverter interrupts the feed-in operation. The cause must be determined by the Service.

Corrective measures:

- Contact Service.

13.2.55 Event 7500**⚠ QUALIFIED PERSON****Event message:**

- Sensor error

Explanation:

Measurement error

Corrective measures:

- Contact Service.

13.2.56 Event 7600**⚠ QUALIFIED PERSON****Event message:**

- Self-diagnosis > Communication error

Explanation:

The cause must be determined by the Service.

Corrective measures:

- Contact Service.

13.2.57 Event 7701**⚠ QUALIFIED PERSON****Event message:**

- Self-diagnosis
- Interference device

Explanation:

The cause must be determined by the Service.

Corrective measures:

- Contact Service.

13.2.58 Event 7702**⚠ QUALIFIED PERSON****Event message:**

- Self-diagnosis
- Interference device

Explanation:

The cause must be determined by the Service.

Corrective measures:

- Contact Service.

13.2.59 Event 7712**⚠ QUALIFIED PERSON****Event message:**

- Self-diagnosis
- Interference device

Explanation:

The cause must be determined by the Service.

Corrective measures:

- Contact Service.

13.2.60 Event 7729**⚠ QUALIFIED PERSON****Event message:**

- Self-diagnosis > Device disturbance
- Backup bypass relay fault

Explanation:

The cause must be determined by the Service.

Corrective measures:

- Contact Service.

13.2.61 Event 8204**⚠ QUALIFIED PERSON****Event message:**

- AFCI self-test failed

Explanation:

An error occurred during the self-test of the arc-fault circuit interrupter (AFCI). It is not guaranteed that the arc-fault circuit interrupter (AFCI) will function correctly. The device does not feed in.

Corrective measures:

- Contact Service.

13.2.62 Event 8903**⚠ QUALIFIED PERSON****Event message:**

- Self-diagnosis
- Interference device

Explanation:

The cause must be determined by the Service.

Corrective measures:

- Contact Service.

13.2.63 Event 29253**Event message:**

- Input power for backup too low

Explanation:

The input power is too low. The battery-backup operation cannot be started. As soon as the minimum input power for the battery-backup operation is reached, the battery-backup operation starts.

Corrective measures:

- Switch off or disconnect backup loads that are not required.

13.2.64 Event 29255**Event message:**

- AC overcurrent backup (fast/slow)

Explanation:

The loads connected to the terminal for backup loads exceed the permissible current.

Corrective measures:

- Check electric circuits of backup loads and the loads connected.
- Disconnect the loads from the electric circuit.

13.2.65 Event 29256**Event message:**

- AC overcurrent backup (fast)

Explanation:

The loads connected to the terminal for backup loads exceed the permissible current.

Corrective measures:

- Check electric circuits of backup loads and the loads connected.
- Disconnect the loads from the electric circuit.

14 Maintenance

14.1 Safety during Maintenance

⚠ DANGER

Danger to life due to electric shock when live components or cables are touched

High voltages are present in the conductive components or cables of the product. Touching live parts and cables results in death or lethal injuries due to electric shock.

- Do not touch non-insulated parts or cables.
- Disconnect the product from voltage sources and ensure it cannot be reconnected before working on the device.
- Wear suitable personal protective equipment for all work on the product.

⚠ DANGER

Danger to life due to electric shock when live components or DC cables are touched

When exposed to light, the PV modules generate high DC voltage which is present in the DC cables. Touching live DC cables results in death or lethal injuries due to electric shock.

- Do not touch non-insulated parts or cables.
- Disconnect the product from voltage sources and ensure it cannot be reconnected before working on the device.
- Do not disconnect the DC connectors under load.
- Wear suitable personal protective equipment for all work on the product.

⚠ WARNING

Danger to life due to electric shock when touching live components or cables while the device is exposed to sunlight

In the event of a fault, a high voltage may be present at the DC terminals on the inverter. Touching live components can result in death or serious injury due to electric shock.

- **Immediately** disconnect the inverter from voltage sources and secure it against being switched on again.
- Stop all work on the inverter until nightfall.
- Wear suitable personal protective equipment of the corresponding hazard risk category for all work.

NOTICE

Damage to the inverter due to unapproved spare parts

If accessories and spare parts not approved by are used for maintenance, the product may be damaged.

- Only use spare parts approved by .

14.2 Servicing Schedule

⚠ QUALIFIED PERSON

Task	Interval
Check the temperature of the inverter and check the inverter for dust contamination. Clean the enclosure if necessary.	Every 6 to 12 months, depending on the environment's dust content

Task	Interval
Check the condition of the air inlet and air outlet and check for dirt and blockages. If necessary, remove dirt and blockages so that the ventilation of the device is ensured again.	Every 6 to 12 months, depending on the environment's dust content
Check if there is a fan event message or if there are unusual noises when the fan is rotating. Clean or replace the external fans if necessary.	Every 12 months
Ensure that all cable glands are sufficiently sealed. Seal the cable glands again if necessary.	Every 12 months
Ensure that all cables are connected correctly and are not damaged. If necessary, correct the connection and replace damaged cables.	Every 6 to 12 months

Also see:

- [Removing the Fan Assembly](#) ⇒ page 104
- [Installing the External Fan Assembly](#) ⇒ page 105
- [Cleaning](#) ⇒ page 104

14.3 Cleaning

The product must be cleaned regularly to ensure that the product is free of dust, leaves and other dirt.

NOTICE

Damage to the product due to cleaning agents

The use of cleaning agents may cause damage to the product and its components.

14.4 Removing the Fan Assembly

⚠ QUALIFIED PERSON

1. Disconnect the inverter from voltage sources and secure it against being switched on again Disconnecting the Inverter from Voltage Sources.

2.

⚠ CAUTION

Risk of burns due to hot enclosure parts

- Wait 30 minutes for the enclosure to cool down.

3. Loosen the spring-loaded cross-head screw (M4).

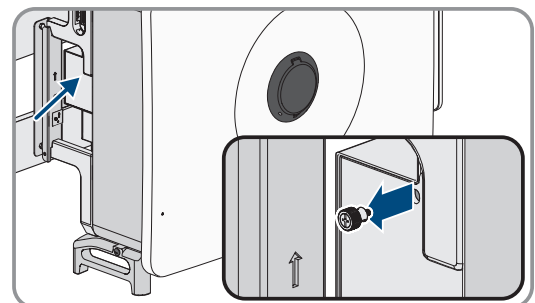

4. Remove the sealing plate of the fan cassette.

5. To release the cable connection, press the clamping bracket together to unlock and pull the cable connection apart.

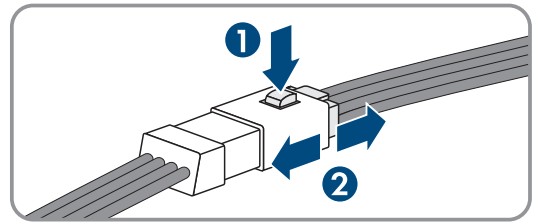

6. Loosen the 2 cross-head screws (M4) on the fan cassette.

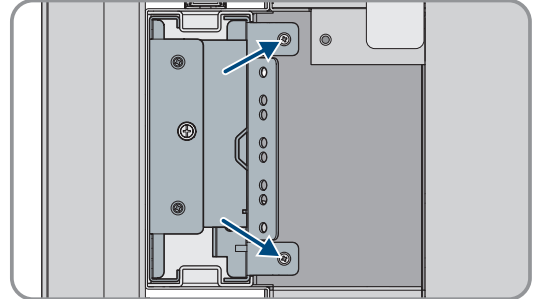

7. Pull the fan cassette out of the inverter.

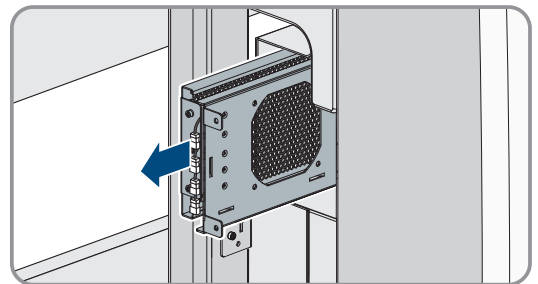

8. Clean Cleaning or replace the fan cassette if necessary.

14.5 Installing the External Fan Assembly

⚠ QUALIFIED PERSON

1. Insert the fan cassette into the inverter.
2. Screw the 2 cross-head screws (M4) to the fan cassette.
3. Plug the cable connectors together and ensure that they are locked.

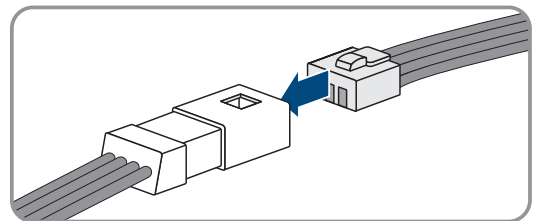

4. Position the sealing plate of the fan cassette.
5. Screw down the spring-loaded cross-head screw (M4).
6. Commission the inverter Commissioning the Inverter.

15 Decommissioning

15.1 Disconnecting the Terminals from the Inverter

To decommission the inverter completely upon completion of its service life, proceed as described in this Section.

Procedure:

1. Disconnect the inverter from voltage sources and secure it against being switched on again. Disconnecting the Inverter from Voltage Sources.

2. **CAUTION**

Risk of burns due to hot enclosure parts

- Wait 30 minutes for the enclosure to cool down.

3. Open the cable compartment (see Section 7, page 31).
4. Open the protective cover.
5. Loosen the conductors L1, L2, L3, N with the ring terminal lugs from the threads at the top using a ratchet.

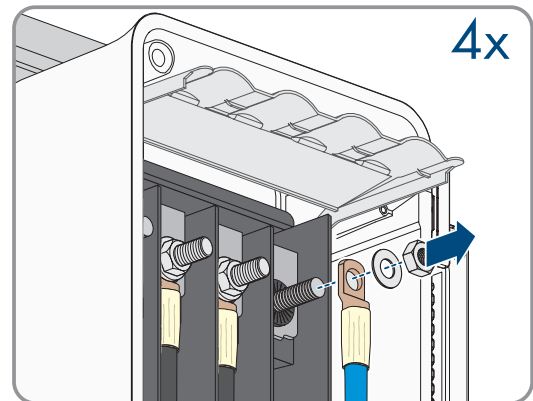

6. Loosen the grounding conductor and the ring terminal lug using a ratchet.
7. Close the protective cover of the cable compartment.
8. Move the limiting lever back to its original position and close the cable compartment cover.
9. Tighten the 2 screws on the cable compartment cover (TX30, tightening torque: 4.2 Nm to 4.5 Nm).

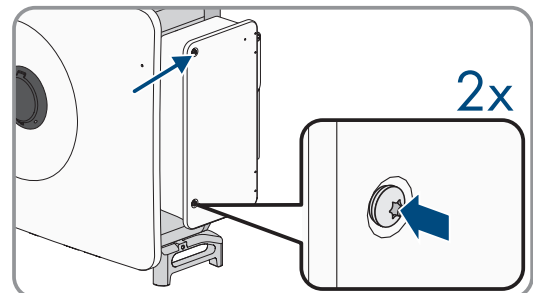

10. Remove the union nut of the cable glands for the communication cable.
11. Remove the cover from the communication connection area.

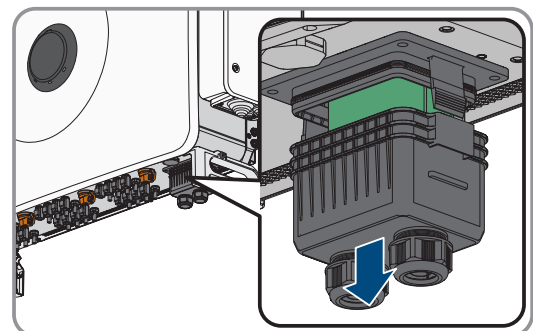

12. Remove all connection cables from the communication assembly.

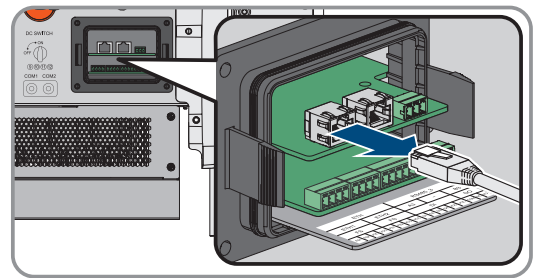

13. Remove the connection cable from the cable gland.

14. Tighten the union nut of the cable gland to the cover hand-tight.

15. Press the cover of the communication connection area back into the inverter.

16. Remove the DC connectors from the inputs.

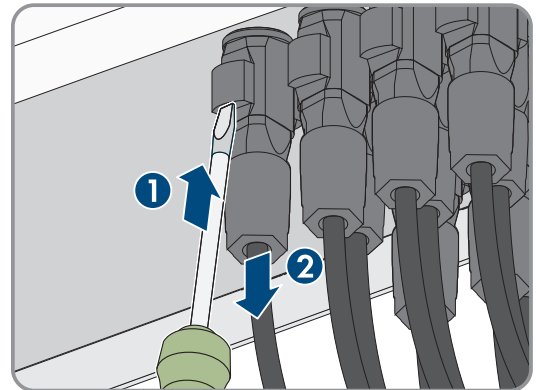

17. Insert sealing plugs onto the DC inputs.

15.2 Disassembling the DC Connectors

⚠ QUALIFIED PERSON

To disassemble the DC connectors for connection to the pv modules (e.g. due to faulty assembly), proceed as follows.

⚠ DANGER

Danger to life due to electric shock when touching exposed DC conductors or DC plug contacts if the DC connectors are damaged or loose

The DC connectors can break or become damaged, become free of the DC cables, or no longer be connected correctly if the DC connectors are released and disconnected incorrectly. This can result in the DC conductors or DC plug contacts being exposed. Touching live DC conductors or DC plug connectors will result in death or serious injury due to electric shock.

- Wear insulated gloves and use insulated tools when working on the DC connectors.
- Ensure that the DC connectors are in perfect condition and that none of the DC conductors or DC plug contacts are exposed.
- Carefully release and remove the DC connectors as described in the following.

Procedure:

1. Release and remove the DC connectors. To do so, insert a flat-blade screwdriver or an angled screwdriver (blade width: 3.5 mm) into one of the side slots and pull the DC connectors out. When doing so, do not lever the DC connectors out, but insert the tool into one of the side slots only to release the locking mechanism, and do not pull on the cable.
2. Remove the DC connector swivel nut.
3. Unlock the DC connector. To do this, insert a flat-blade screwdriver (blade width: 3.5 mm) into the side catch mechanism and pry the catch mechanism open.

4. Carefully pull the DC connector apart.
5. Release the clamping bracket. To do so, insert a flat-blade screwdriver (blade width: 3.5 mm) into the clamping bracket and pry the clamping bracket open.

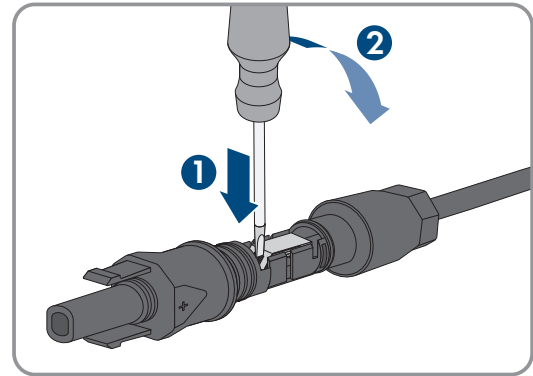

6. Remove the cable.

15.3 Disassembling the Inverter

Requirements:

- Original packaging or packaging suitable for the weight and dimensions of the product must be available.
- A pallet must be available.
- Mounting material for attaching the packaging on the pallet must be available (e.g. tie-down straps).
- All transport handles must be in place.

Procedure:

1. Remove the sealing screws on the sides of the inverter using a flat-blade screwdriver (4 mm).

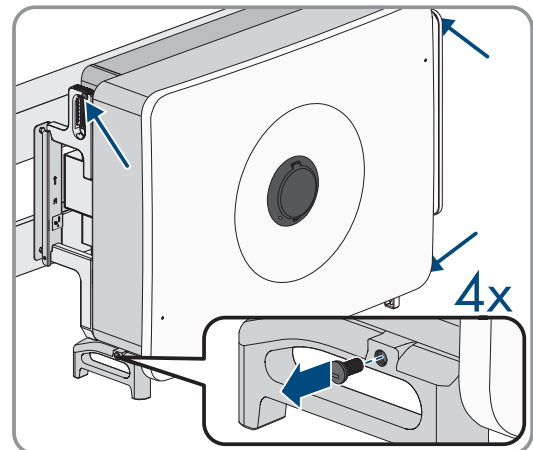

2. Screw all 4 carrying handles or the eye bolts of the lifting gear into the threaded holes.
3. If the inverter is to be unhooked from the mounting bracket using lifting gear, screw the eye bolts into the 2 upper threaded holes on the right-hand and left-hand side of the inverter and attach the lifting gear to them. The lifting gear must be suitable to take the weight of the inverter.
4. If the inverter is to be lifted out of the mounting bracket without using lifting gear, screw the carrying handles as far as they will go into the threaded holes on the right-hand and left-hand side until they lie flush with the enclosure. When doing so, ensure that the carrying handles are screwed into the threaded holes so that they are perfectly straight. If the carrying handles are not screwed in straight, this can make it more difficult or even impossible to unscrew them later on and can damage the threaded holes to the extent that carrying handles can no longer be screwed into them.

5. Remove the hexagon head screws (M6xM65) from the mounting bracket.

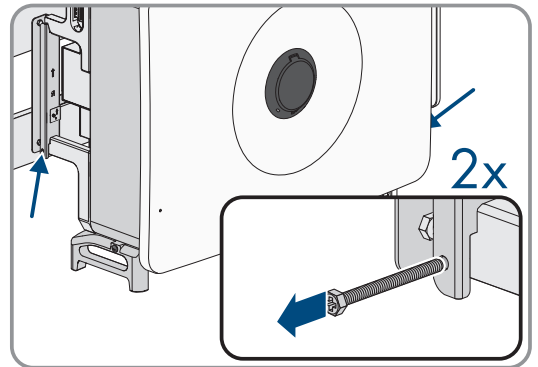

6. Unhook the inverter from the mounting bracket.

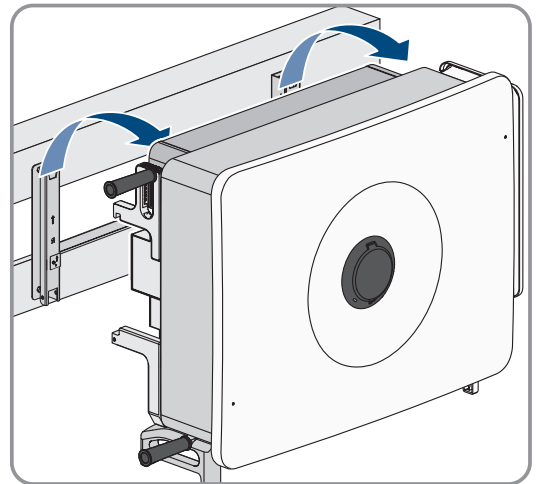

7. If the inverter is to be shipped, pack the inverter according to its size and weight.
8. Dispose of the inverter in accordance with the locally applicable disposal regulations for electronic waste.

16 Disposal

The product must be disposed of in accordance with the locally applicable disposal regulations for waste electrical and electronic equipment.



17 Technical Data

17.1 General Data

Width x height x depth	1020 mm x 795 mm x 410 mm
Weight	96 kg
Way of attaching	Wall mounting bracket
Operating temperature range	-30°C to +60°C
Max. permissible value for relative humidity (condensing)	100%
Maximum operating altitude above mean sea level (MSL)	4000 m
Typical noise emission	< 71 dB(A)
Power loss in night mode	< 6.5 W
Topology	Without transformers
Cooling method	Active cooling
Degree of protection for electronics in accordance with IEC 60529	IP65
Corrosivity classification according to IEC 61701 (at a minimum distance of 0.5 km (0.3 mile) from the coast)	C5
Protection class in accordance with IEC 62109-1	I
Radio technology	Wi-Fi 802.11 b/g/n or Ethernet
Radio spectrum	2.4 GHz
Maximum transmission power	100 mW
Wi-Fi range in free-field conditions	10 m (33 ft)
Quantity maximum detectable Wi-Fi networks	32
Grid conformity ¹⁾	IEC 62109-1/-2, EN50549-1/-2/-10, G99/1, C10/11, VDE-AR-N 4105/4110/4120:2018, AS/NZS4777.2
Grid Support	LVRT, HVRT, active and reactive power control and power ramp rate control
Power control / Demand response (DRED)	Communication via Modbus interface
Demand response mode in accordance with AS/NZS 4777.2	DRM0
Decisive Voltage Class (DVC) in accordance with AS/NZS 4777.2	C

¹⁾ The version currently valid is available in the download area at www.SMA-Solar.com.

17.2 DC Input

Maximum PV array power	187500 W _p STC
Maximum input voltage	1100 V
Minimum input voltage	180 V
Starting voltage	200 V
Rated input voltage	600 V
MPP voltage range	180 V to 800 V ²⁾
MPP Voltage Range for rated power	450 V to 800 V ³⁾
Number of independent MPP inputs	12
Strings per MPP input	2
Maximum usable input current	360 A (30 A * 12)
Maximum short-circuit current per input	480 A (40 A * 12) ⁴⁾
Maximum reverse current into the PV array	0 A ⁵⁾
Overvoltage category as per IEC 62109-1	AC: III, DC: II
Maximum PV module coupling capacity to ground according to IEC 63112	18.75 μF

17.3 AC Output

Rated power (at 230 V, 50 Hz)	125000 W
Maximum output power	125 kW
Maximum apparent power	125 kVA
Maximum output current	181.1 A
Grid output current at 230 V	181.1 A
Rated AC voltage	3 / N / PE, 230 V / 400 V
Voltage range	320 V to 480 V* as per IEC 62109-2: ISC PV
Maximum active power of the generation unit at 0.9 V _n	112.5 kW ⁶⁾
Inrush current	< 10% of the nominal AC current for a max. of 10 ms
Total harmonic distortion	< 3%
Grid frequency	50 Hz / 60 Hz

²⁾ Input voltages of up to 1000 V are possible; however, this will result in reduced power output.

³⁾ To ensure optimal operation, ensure that the voltage difference between 2 MPP tracking entries does not exceed 80 V.

⁴⁾ In accordance with IEC 62109-2: I_{SC,PV}

⁵⁾ The topology prevents a reverse current from the inverter in the system.

⁶⁾ Compliant with VDE AR-N-4110

Operating range at grid frequency 50 Hz	45 Hz to 55 Hz
Operating range at grid frequency 60 Hz	55 Hz to 65 Hz
Displacement power factor, adjustable	0.8 overexcited to 0.8 underexcited
Power factor at rated power	1
Feed-in phases	3
AC connection	3-N-PE

17.4 Efficiency

Maximum efficiency, η_{\max}	98.4 %
European weighted efficiency, η_{EU}	98.1 %

17.5 Protective devices

Grid monitoring	Available
Input-side disconnection point	DC load-break switch ⁷⁾
DC reverse polarity protection	Available
AC short-circuit current capability	Available
Leakage current protection	Available
AC overvoltage protection"	Surge arrester type 2
DC overvoltage protection	Surge arrester type 1+2
Ground fault monitoring	Insulation monitoring: $R_{\text{iso}} > 50 \text{ k}\Omega$
DC switch	Available
Arc-fault circuit interrupter (AFCI)	Available
Maximal output overcurrent protection	375 A
All-pole sensitive residual-current monitoring unit	Available
Active anti-islanding method	Frequency shift

17.6 Equipment

DC Connection	SUNCLIX DC connector
AC terminal	Ring terminal lug
Multifunction relay	By default, $\leq 30 \text{ V} / 1 \text{ A}$
Digital inputs	1 x fast stop, 4x active power reduction

⁷⁾ Usage category according to IEC 60947: DC-PV2

18 Contact

If you experience any technical problems with our products, please contact the Service. The following data is required in order to provide you with the necessary assistance:

- Device type
- Serial number
- Firmware version
- Event message
- Installation site and mounting height
- Type of communication
- Type and number of PV modules
- Type of the communication products connected
- Use the name of the system in Sunny Portal (if available)
- Access data for Sunny Portal (if available)
- Special country-specific settings (if available)
- Detailed description of the problem

You can find your country's contact information at:



<https://go.sma.de/service>

19 EU Declaration of Conformity

within the scope of the EU directives



- Electromagnetic compatibility 2014/30/EU (29.3.2014 L 96/79-106) (EMC)
- Low Voltage Directive 2014/35/EU (29.3.2014 L 96/357-374) (LVD)
- Radio Equipment Directive 2014/53/EU (22.5.2014 L 153/62) (RED)
- Restriction of the use of certain hazardous substances 2011/65/EU (L 174/88, June 8, 2011) and 2015/863/EU (L 137/10, March 31, 2015) (RoHS)

confirms herewith that the products described in this document are in compliance with the fundamental requirements and other relevant provisions of the aforementioned directives. More information on the availability of the entire Declaration of Conformity can be found at <https://www.sma.de/en/ce-ukca>.

Radio technology	WLAN 802.11 b/g/n
Radio spectrum	2.4 GHz
Maximum transmission power	100 mW

ENERGY
THAT
CHANGES



www.SMA-Solar.com

