



SMA Backup Select

BU-SLCT-US-50

eManual



Legal Provisions

The information contained in these documents is the property of SMA Solar Technology AG. No part of this document may be reproduced, stored in a retrieval system, or transmitted, in any form or by any means, be it electronic, mechanical, photographic, magnetic or otherwise, without the prior written permission of SMA Solar Technology AG. Internal reproduction used solely for the purpose of product evaluation or other proper use is allowed and does not require prior approval.

SMA Solar Technology AG makes no representations or warranties, express or implied, with respect to this documentation or any of the equipment and/or software it may describe, including (with no limitation) any implied warranties of utility, merchantability, or fitness for any particular purpose. All such representations or warranties are expressly disclaimed. Neither SMA Solar Technology AG nor its distributors or dealers shall be liable for any indirect, incidental, or consequential damages under any circumstances.

The exclusion of implied warranties may not apply in all cases under some statutes, and thus the above exclusion may not apply.

Specifications are subject to change without notice. Every attempt has been made to make this document complete, accurate and up-to-date. Readers are cautioned, however, that product improvements and field usage experience may cause SMA Solar Technology AG to make changes to these specifications without advance notice or per contract provisions. SMA Solar Technology AG shall not be responsible for any damages, including indirect, incidental or consequential damages, caused by reliance on the material presented, including, but not limited to, omissions, typographical errors, arithmetical errors or listing errors in the content material.

SMA Warranty

You can download the current warranty conditions from the Internet at www.SMA-Solar.com.

Trademarks

All trademarks are recognized, even if not explicitly identified as such. Missing designations do not mean that a product or brand is not a registered trademark.

SMA Solar Technology AG

Sonnenallee 1

34266 Niestetal

Germany

Tel. +49 561 9522-0

Fax +49 561 9522-100

www.SMA.de

E-mail: info@SMA.de

Status: Friday, August 8, 2025

Copyright © 2025 SMA Solar Technology AG. All rights reserved.

Table of contents

1	Information on this Document.....	5
1.1	Validity.....	5
1.2	Target Group.....	5
1.3	Content and Structure of this Document.....	5
1.4	Levels of Warning Messages.....	5
1.5	Symbols in the Document.....	5
1.6	Typographies in the document.....	6
1.7	Designations in the Document.....	6
1.8	Symbols on the Product.....	6
1.9	Additional Information.....	7
2	Safety.....	8
2.1	Intended Use.....	8
2.2	IMPORTANT SAFETY INFORMATION.....	8
3	Scope of Delivery.....	10
4	Product overview.....	11
4.1	Information about the automatic backup system.....	11
4.1.1	Purpose of an Automatic Backup System.....	11
4.1.2	Function of the automatic transfer switching device.....	11
4.1.3	How automatic backup operation works.....	11
4.2	System Overview.....	12
4.3	Circuitry Overview.....	13
4.4	Product Description.....	14
5	Mounting.....	15
5.1	Optional: Prepare the enclosure.....	15
5.2	Wall Mounting.....	15
5.3	Optional: Remove lid.....	16
5.4	Removing the installation cover.....	17
6	Electrical Connection.....	19
6.1	Requirements for the electrical connection.....	19
6.1.1	Common Grid Configurations.....	19
6.1.2	SPS IN signal cable requirements.....	19
6.1.3	Requirements on the SPS OUT AC cable for connection to the inverter.....	20
6.1.4	AC Cable Requirements for Connections to Backup Power Loads.....	20
6.1.5	AC Cable Requirements for Connections to the Utility Grid.....	20
6.1.6	Requirements on the AC cable to the inverter.....	20
6.2	Enclosure opening.....	21
6.3	Overview of the Connection Area.....	22
6.4	Removing the grounding conductor connection on the inverter.....	23
6.5	Connecting the connections to the automatic transfer switching device.....	24
7	Operation.....	29
7.1	Operation with SMA 360° App.....	29
7.1.1	Updating the inverter firmware version with SMA 360° App.....	29
7.1.2	Setting Parameters for Automatic Backup Operation Using SMA 360° App.....	29
7.2	Operation via User Interface.....	31
7.2.1	Updating the inverter firmware version.....	31

7.2.2	Changing parameters	31
7.2.3	Setting parameters for automatic backup operation	32
7.3	Testing automatic backup operation	33
8	Closing the enclosure.....	34
9	Troubleshooting	35
10	Decommissioning the Product.....	36
11	Disposal	37
12	Technical Data	38
12.1	General Data	38
12.2	Parallel grid operation.....	38
12.3	Automatic backup.....	38
12.4	Switchover times (adjustable parameters)	39
13	Contact	40

1 Information on this Document

1.1 Validity

This document is valid for:

- BU-SLCT-US-50 (SMA Backup Select)

1.2 Target Group

The tasks described in this document must only be performed by qualified persons. Qualified persons must have the following skills:

- Knowledge of how to safely disconnect SMA inverters
- Knowledge of how an inverter works and is operated
- Knowledge of how batteries work and are operated
- Training to deal with risks associated with installing, repairing, and using electrical devices, inverters, and batteries
- Training in the installation and commissioning of electrical devices and installations
- Knowledge of all applicable laws, regulations, standards, and directives
- Knowledge of and compliance with this document and all safety information
- Knowledge of and compliance with the documents of the battery manufacturer with all safety information

1.3 Content and Structure of this Document

This document describes the installation, commissioning and decommissioning of the product.

Illustrations in this document are reduced to the essential information and may deviate from the real product.

1.4 Levels of Warning Messages

The following levels of warning messages may occur when handling the product.

DANGER

Indicates a hazardous situation which, if not avoided, will result in death or serious injury.

WARNING

Indicates a hazardous situation which, if not avoided, could result in death or serious injury.



CAUTION



Indicates a hazardous situation which, if not avoided, could result in minor or moderate injury.

NOTICE

Indicates a situation which, if not avoided, can result in property damage.

1.5 Symbols in the Document

Symbol	Explanation
	Information that is important for a specific topic or goal, but is not safety-relevant
	Indicates a requirement for meeting a specific goal

Symbol	Explanation
	Required result
	Example



1.6 Typographies in the document



Typography	Use	Example
bold	<ul style="list-style-type: none"> • Messages • Terminals • Elements on a user interface • Elements to be selected • Elements to be entered 	<ul style="list-style-type: none"> • Connect the insulated conductors to the terminals X703:1 to X703:6. • Enter 10 in the field Minutes.
>	<ul style="list-style-type: none"> • Connects several elements to be selected 	<ul style="list-style-type: none"> • Go to Settings > Date.
[Button] [Key]	<ul style="list-style-type: none"> • Button or key to be selected or pressed 	<ul style="list-style-type: none"> • Select [Enter].
#	<ul style="list-style-type: none"> • Placeholder for variable components (e.g., parameter names) 	<ul style="list-style-type: none"> • Parameter WClHz.Hz#

1.7 Designations in the Document

Complete designation	Designation in this document
SMA Backup Select	Product, automatic transfer switching device
Sunny Boy Smart Energy	Inverter, hybrid inverter
SMA Home Energy Solution	System

1.8 Symbols on the Product



Symbol	Explanation
	<p>Beware of electrical voltage</p> <p>The product operates at high voltages.</p>
	<p>Beware of hot surface</p> <p>The product can get hot during operation.</p>
	<p>Observe the documentation</p> <p>Observe all documentations supplied with the product.</p>
Enclosure Type 3R	<p>Enclosure Type 3R</p> <p>The product is suitable for indoor or outdoor use and offers protection against: falling dirt (no dust protection), dripping water / light splashing water, rain, sleet, snow and external ice formation</p>

Symbol	Explanation
	The product is suitable for outdoor installation.
	Equipment Grounding Terminal This symbol indicates the position for the connection of an equipment grounding conductor.
	UL 1741 and CSA C22.2 No. 107.1 are the standards applied by Underwriters Laboratories to the product to certify that it meets the requirements of the <i>National Electrical Code</i> [®] and the <i>Canadian Electrical Code</i> [®] .

1.9 Additional Information

When installing the automatic transfer switching device, also observe the manuals for the other components used in the system.

Additional information is available at www.SMA-Solar.com.

Title and information content	Type of information	QR code
Operating manual SUNNY BOY SMART ENERGY 3.8-US / 4.8-US / 5.8-US / 7.7-US / 9.6-US / 11.5-US	Operating manual	
"Approved Batteries and Information on Battery Communication Connection" Overview of approved batteries	Technical Information	

2 Safety

2.1 Intended Use

SMA Backup Select is an automatic transfer switching device that enables single-phase automatic backup operation in the SMA Home Energy Solution with the SMA inverters listed below. In the event of a power failure, the hybrid inverter ensures that SMA Backup Select automatically switches to automatic backup operation and the hybrid inverter can supply the loads connected to the automatic backup system with power from the battery and the PV system.

The neutral conductor of SMA Backup Select is not switched.

SMA Backup Select must only be used with the following SMA inverters:

- SBSE3.8-US-50 (Sunny Boy Smart Energy 3.8-US)
- SBSE4.8-US-50 (Sunny Boy Smart Energy 4.8-US)
- SBSE5.8-US-50 (Sunny Boy Smart Energy 5.8-US)
- SBSE7.7-US-50 (Sunny Boy Smart Energy 7.7-US)
- SBSE9.6-US-50 (Sunny Boy Smart Energy 9.6-US)
- SBSE11.5-US-50 (Sunny Boy Smart Energy 11.5-US)

The product is intended for installation as a separate accessory.

The product must be mounted on a sufficiently load-bearing and closed wall.

The product is intended for use in residential and industrial environments.

The product is suitable for indoor and outdoor use.

The product must not be installed in areas exposed to direct solar irradiation or must be protected from direct solar irradiation by appropriate measures.

All components must remain within their permitted operating ranges and their installation requirements at all times.

Use SMA products only in accordance with the information provided in the enclosed documentation and with the locally applicable laws, regulations, standards and directives. Any other application may cause personal injury or property damage.

The documentation must be strictly followed. Deviations from the described actions and the use of materials, tools, and aids other than those specified by SMA Solar Technology AG are expressly forbidden.

Alterations to the SMA products (except those described here), e.g., changes or modifications, are only permitted with the express written permission of SMA Solar Technology AG. Unauthorized alterations as well as failure to observe the documentation will void guarantee and warranty claims and in most cases terminate the operating license. SMA Solar Technology AG shall not be held liable for any damage caused by such changes.

Any use of the product other than that described in the Intended Use section does not qualify as appropriate.

The documentation supplied is an integral part of SMA products. Keep the documentation in a convenient, dry place for future reference and observe all instructions contained therein.

This document does not replace any regional, state, provincial, federal or national laws, regulations or standards that apply to the installation, electrical safety and use of the product. SMA Solar Technology AG assumes no responsibility for the compliance or non-compliance with such laws or codes in connection with the installation of the product.

2.2 IMPORTANT SAFETY INFORMATION

Keep the manual for future reference.

This section contains safety information that must be observed at all times when working.

The product has been designed and tested in accordance with international safety requirements. As with all electrical or electronical devices, some residual risks remain despite careful construction. To prevent personal injury and property damage and to ensure long-term operation of the product, read this section carefully and observe all safety information at all times.

⚠ DANGER**Danger to life due to electric shock when live components or conductors within the system are touched**

The neutral conductor of the product is not switched. As a result, the capacitive leakage currents of the PV modules are present on the neutral conductor and the neutral conductor is live if the connection to the grounding conductor is interrupted.

- For any work during which the neutral conductor connection is interrupted, the automatic backup system must be taken out of operation and secured against being switched back on.

⚠ DANGER**Danger to life due to electric shock when live components or DC cables are touched**

The DC cables connected to a battery or a PV module may be live. Touching live DC cables results in death or serious injury due to electric shock.

- Disconnect the system from voltage sources and make sure it cannot be reconnected before working on the device.
- Wait five minutes before working on the inverter.
- Observe all safety information of the battery manufacturer.
- Do not touch non-insulated parts or cables.
- Do not pull the DC conductors under load out of the terminal blocks.
- Wear suitable personal protective equipment for all work on the product.

NOTICE**Damage to the system due to sand, dust and moisture ingress**

Sand, dust and moisture penetration can damage the products of the system and impair its functionality.

- Only open the product if the humidity is within the thresholds and the environment is free of sand and dust.
- Do not open the product during a dust storm or precipitation.
- Close the product in case of interruption of work or after finishing work.
- Only operate the product when it is closed.
- Close tightly all enclosure openings.

NOTICE**Damage to the enclosure seal in subfreezing conditions**

If you open the product when temperatures are below freezing, the enclosure seals can be damaged. Moisture can penetrate the product and damage it.

- Only open the product if the ambient temperature is not below -5°C (23°F).

3 Scope of Delivery

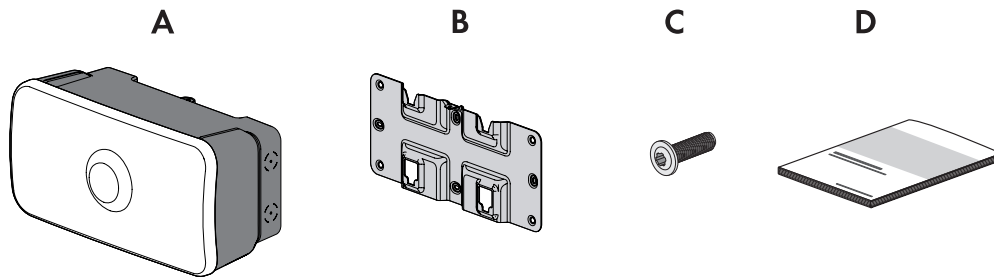

Position	Quantity	Designation
A	1	Automatic transfer switching device
B	1	Wall mounting bracket
C	1	Screw for securing the automatic transfer switching device to the wall mounting bracket
D	1	Documentation package consists of: <ul style="list-style-type: none"> • Safety information booklet • Quick reference guide poster with illustrated instructions for initial installation and commissioning • Poster with circuitry overview

4 Product overview

4.1 Information about the automatic backup system

4.1.1 Purpose of an Automatic Backup System

Any time a grid failure happens, a PV system disconnects from the utility grid and the loads connected to the household grid are no longer supplied with energy.

A grid failure lasting for a longer period can have serious consequences for the parties concerned such as:

- Households and companies would have to manage without heat, light, telephone and computer.
- Refrigeration could be interrupted.
- For example, if stable ventilation systems or heat lamps lose power in a farming business.

Possible solutions for bridging this supply gap is to convert existing PV systems into automatic backup systems, or to design new systems as automatic backup systems.

The automatic transfer switching device takes care of the uninterrupted supply of the loads with electricity during a grid failure. The automatic transfer switching device disconnects the household grid with the PV system from the utility grid. The hybrid inverter then creates an automatic backup grid, and the PV system can thus continue to supply power to the loads. When the energy demand of the active loads exceeds the current power of the PV system, the battery will provide the energy shortfall.

4.1.2 Function of the automatic transfer switching device

Function	Description
Grid Disconnection	The grid disconnection isolates the automatic backup grid from the utility grid if there is a grid failure.

4.1.3 How automatic backup operation works

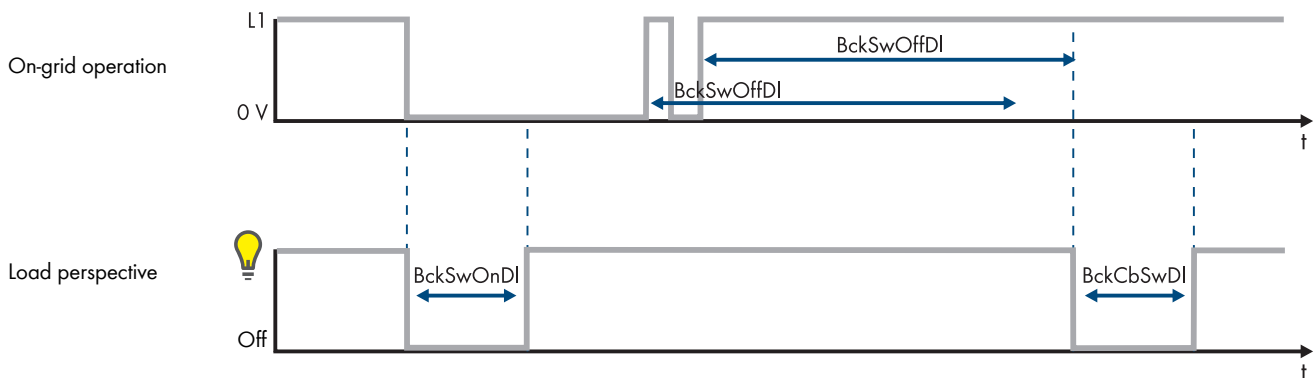

Operation.BckSwOnDI = 5 s
 Operation.BckSwOffDI = 300 s
 Operation.BckCbSwDI = 5 s

Set parameters for automatic backup operation Setting parameters for automatic backup operation.

4.3 Circuitry Overview

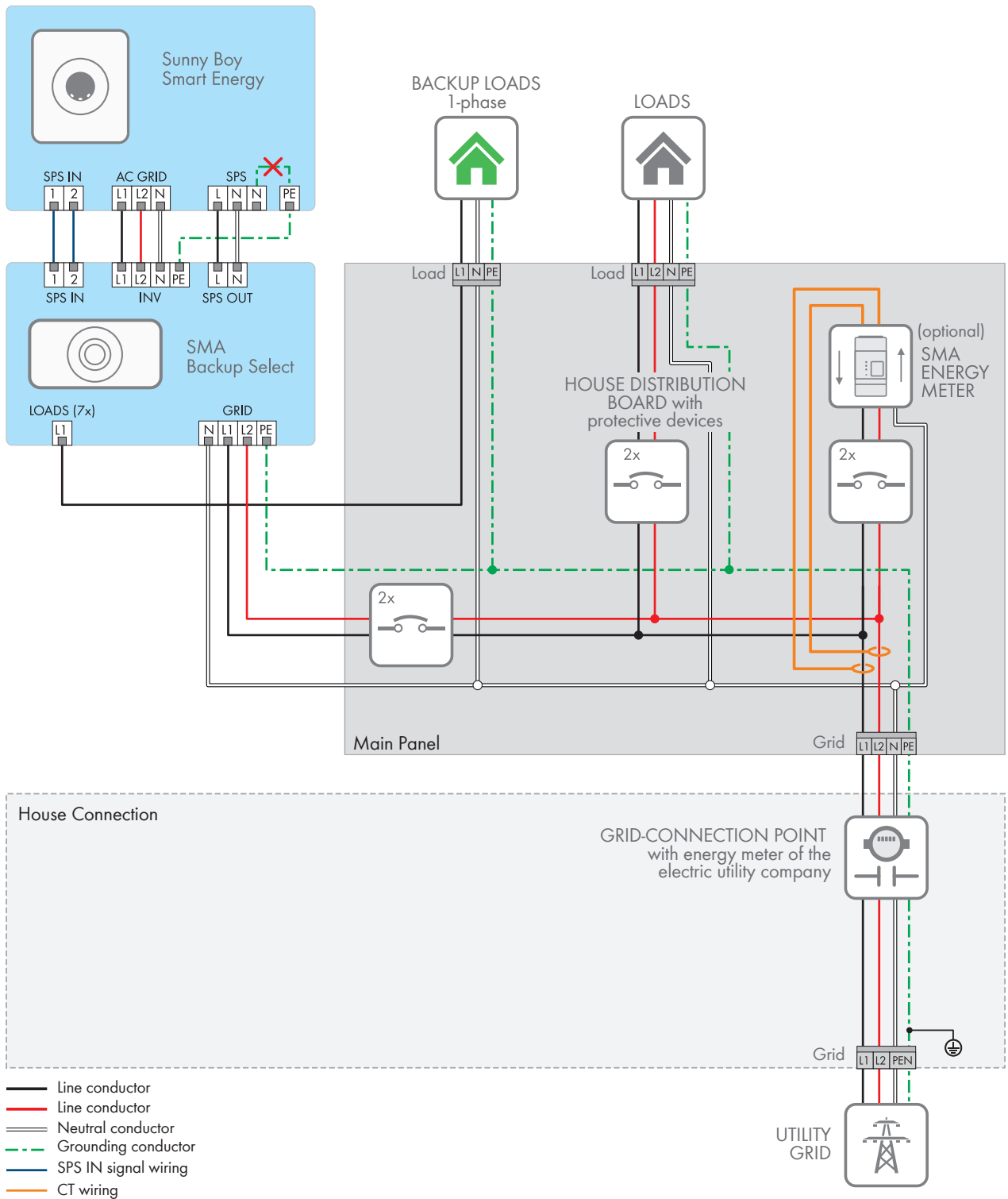

Figure 2: Backup Select circuitry overview

4.4 Product Description

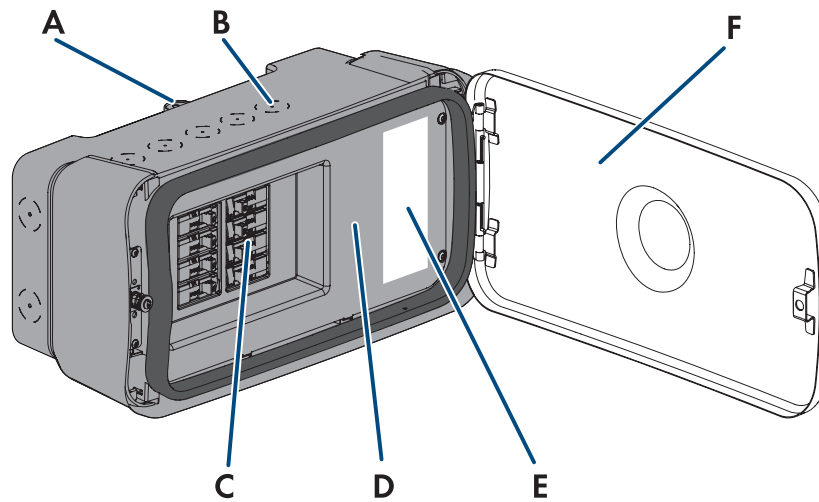

Figure 3: Design of the product

Position	Designation
A	Fastening for attachment to the wall mounting bracket
B	Holes for enclosure opening
C	Fuses for loads
D	Installation cover
E	Type label
F	Lid

5 Mounting

5.1 Optional: Prepare the enclosure

Holes for enclosure opening are already provided on the top and bottom of the enclosure of the automatic transfer switching device. If the automatic transfer switching device is to be mounted in a different location, for example to the right or left of the inverter, you have the option of adapting the enclosure to meet your requirements. Possible holes are marked on the right, left, top and bottom.

Procedure:

1. Drill the required holes with a step drill. The holes must not be larger than the size marked on the enclosure. When drilling, make sure that no internal cables or components of the automatic transfer switching device are damaged. If necessary, remove components from the automatic transfer switching device before drilling.
2. Remove drilling chips from the enclosure.
3. Before installation, observe the minimum distance to the inverter (see product manual).

5.2 Wall Mounting

Additionally required material:

- 2 screws that are suitable for the support surface and the weight of the automatic transfer switching device
- 2 washers that are suitable for the support surface and the weight of the automatic transfer switching device.
- Where necessary, 2 screw anchors suitable for the support surface and the screws

Requirements:

- To avoid overheating, do not install the automatic transfer switching device where it is exposed to direct solar irradiation, or it must be protected from direct solar irradiation by appropriate measures.

Procedure:

1. Set the position for the automatic transfer switching device. Consider the possible cable route. The automatic transfer switching device can be installed to the right or left of the inverter, or under the inverter. SMA Solar Technology recommends installing the automatic transfer switching device under the inverter. The automatic transfer switching device must be mounted on a sufficiently load-bearing and closed wall.
2. Align the wall mounting bracket horizontally on the wall and mark the position of the drill holes.

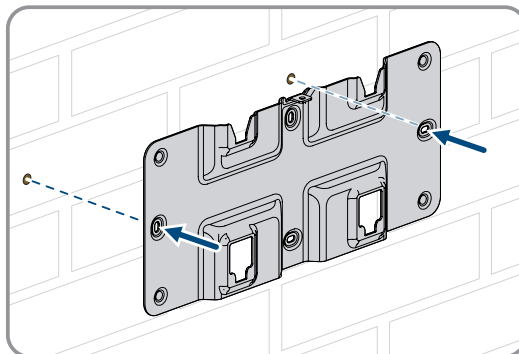

3. Set the wall mounting bracket aside and drill the marked holes.
4. Insert screw anchors into the drill holes if the support surface requires them.

5. Secure the wall mounting bracket horizontally using screws and washers.

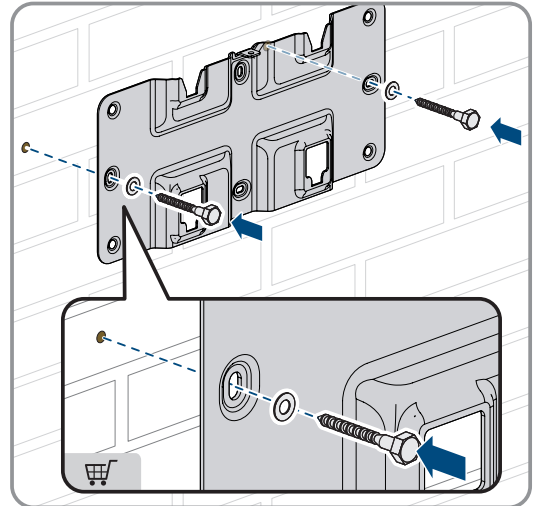

6. Hang the automatic transfer switching device onto the wall mounting bracket from above.

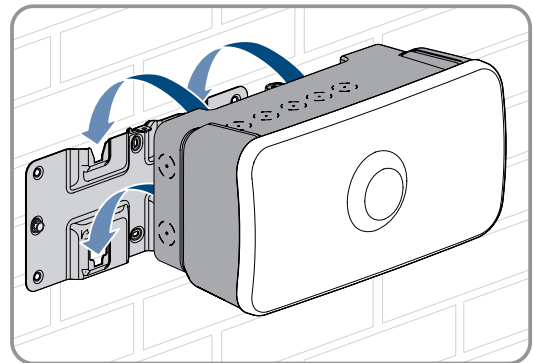

7. Make sure that the automatic transfer switching device is correctly mounted on the wall mounting bracket.
8. Insert the supplied screw (M4x16, TX20) into the hole to secure the automatic transfer switching device to the wall mounting bracket and tighten the screw.

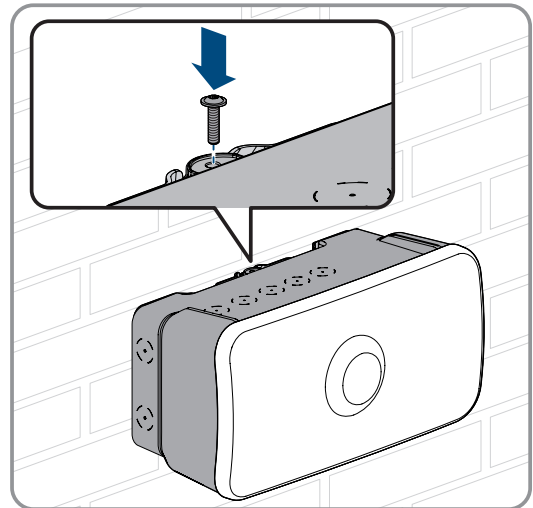

5.3 Optional: Remove lid

If necessary, you can remove the lid of the enclosure of the automatic transfer switching device. This can be helpful during installation or electrical connection, for example.

Procedure:

1. Open the lid of the enclosure. To do this, press on the left side of the lid with your hand.

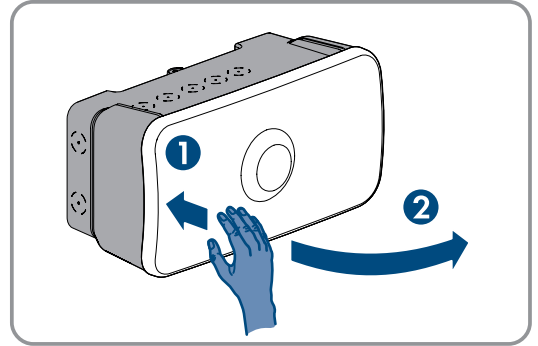

2. Open the hinge. To do this, press the two latches down or up.
Information: The hinge is easier to open if the enclosure lid is not opened all the way back.

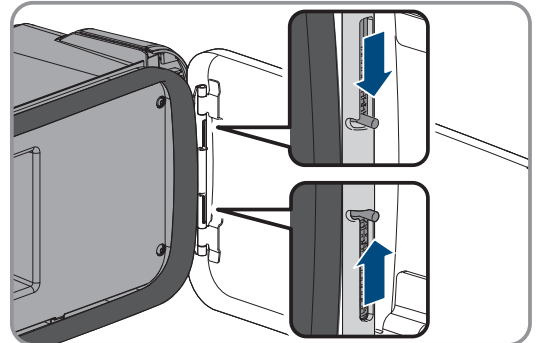

3. Slide the two latches into the opening of the hinge.

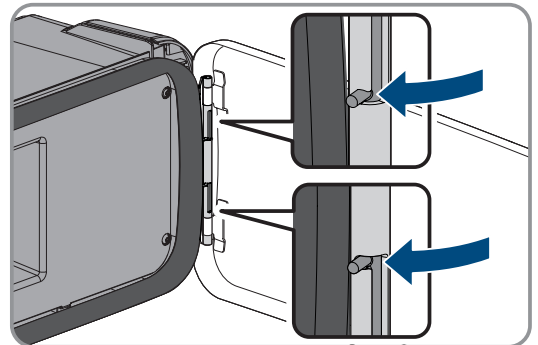

4. Remove the lid.

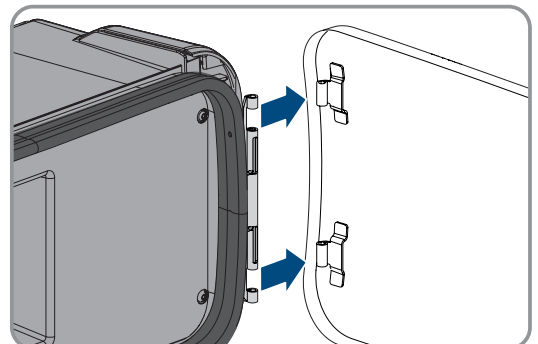

5.4 Removing the installation cover

Requirement:

- The lid of the enclosure of the automatic transfer switching device has been opened or removed.

Procedure:

1. Disconnect the inverter from voltage sources (see inverter manual).
2. If available, switch off the battery (see battery manual).

3. Loosen the 4 screws (TX20) for fastening the installation cover.

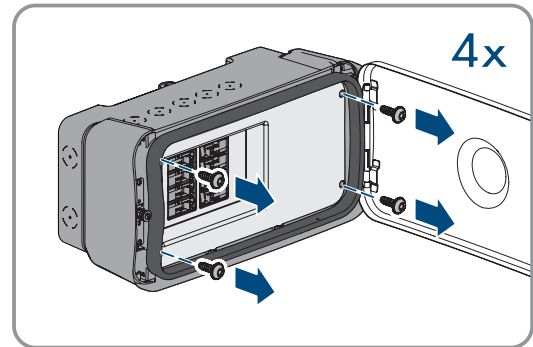

4. Remove the installation cover.

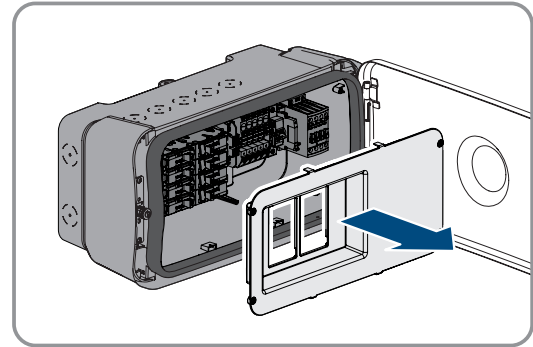

6 Electrical Connection

6.1 Requirements for the electrical connection

6.1.1 Common Grid Configurations

The connection procedure varies depending on the grid configuration. The following table provides an overview of common grid configurations, which conductors have to be connected to the inverter to comply with the grid configuration and which country data set can be set. The inverter is designed to connect to a utility grid with either a 240 V split-phase system or a 208 V wye-connection system as standard. The grid configuration is set separately from the country data set. For an overview of these and other grid types, please refer to the technical information "INVERTERS & UTILITY GRID CONFIGURATION" in the download area at www.SMA-Solar.com.

For 208 V grids, note the settings for the grid support functions (see inverter manual).

Compatible grid configuration	Conductors to be connected	Configurable country data sets
120 / 240 V split-phase system	L1, L2 and N	<ul style="list-style-type: none"> • [CA] CSA C22.3 No.9:20
120 / 208 V wye connection	L1, L2 and N	<ul style="list-style-type: none"> • [Offgrid] SMA stand-alone mode 50 Hz PV inverter • [Offgrid] SMA stand-alone mode 60 Hz PV inverter • [US] CA-R21 IEEE1547:2018 Cat.B III: Used when the requirements of California Rule 21 must be met. • [US] UL1741/SB Cat B-III Storage: Supports the requirements of large-scale PV power plants and distribution networks in accordance with California Rule 21 and Hawaii Rule 14H. Used if the utility company does not specify a specific country data set and there is a battery in the system. • [US] UL1741/SB Cat.B-II: Supports voltage ride through (VRT) from DER for all large-scale PV power plants. • [US] UL1741/SB Cat.B-II Storage: Supports voltage ride through (VRT) from DER for all large-scale PV power plants with battery. • [US] UL1741/SB Cat.B-III: Supports the requirements of large-scale PV power plants and distribution networks in accordance with California Rule 21 and Hawaii Rule 14H. Used if the utility company does not specify a specific country data set.

6.1.2 SPS IN signal cable requirements

The cable length and quality affect the quality of the signal. Observe the following cable requirements:

- Conductor type: copper wire
- Permissible temperature: at least 90°C (194°F)
- The conductors must be solid or stranded wire.
- Conductor cross-section: 0.8 mm² to 1.5 mm² (18 AWG to 16 AWG)

- Insulation stripping length: 6 mm
- Nominal voltage: at least 600 V
- Maximum length of conductors: 30 m (98 ft)
- The conductors with regards to their ampacity, rated temperatures, operating conditions and power loss must be made in accordance with the local standards and the *National Electrical Code*® ANSI/NFPA 70. If the manufacturer (SMA Solar Technology AG) requires a higher conductor cross-section than the standard, the range of the manufacturer must be observed.

6.1.3 Requirements on the SPS OUT AC cable for connection to the inverter

The cable length and quality affect the quality of the signal. Observe the following cable requirements:

- Conductor type: copper wire
- Permissible temperature: at least 90°C (194°F)
- The conductors must be solid or stranded wire.
- Conductor cross-section: 1.5 mm² to 2.5 mm² (16 AWG to 14 AWG)
- Insulation stripping length: 6 mm
- Nominal voltage: at least 600 V
- Maximum length of conductors: 30 m (98 ft)
- The conductors with regards to their ampacity, rated temperatures, operating conditions and power loss must be made in accordance with the local standards and the *National Electrical Code*® ANSI/NFPA 70. If the manufacturer (SMA Solar Technology AG) requires a higher conductor cross-section than the standard, the range of the manufacturer must be observed.

6.1.4 AC Cable Requirements for Connections to Backup Power Loads

- Conductor type: copper wire
- Permissible temperature: at least 90°C (194°F)
- The conductors must be solid or stranded wire.
- Conductor cross-section: 1.5 mm² to 6 mm² (16 AWG to 10 AWG)
- Insulation stripping length: 18 mm (0.7 in)
- The conductors with regards to their ampacity, rated temperatures, operating conditions and power loss must be made in accordance with the local standards and the *National Electrical Code*® ANSI/NFPA 70. If the manufacturer (SMA Solar Technology AG) requires a higher conductor cross-section than the standard, the range of the manufacturer must be observed.

6.1.5 AC Cable Requirements for Connections to the Utility Grid

- Conductor type: copper wire
- Permissible temperature: at least 90°C (194°F)
- The conductors must be solid or stranded wire.
- Conductor cross-section: 10 mm² to 16 mm² (6 AWG to 4 AWG)
- Insulation stripping length: 18 mm (0.7 in)
- The conductors with regards to their ampacity, rated temperatures, operating conditions and power loss must be made in accordance with the local standards and the *National Electrical Code*® ANSI/NFPA 70. If the manufacturer (SMA Solar Technology AG) requires a higher conductor cross-section than the standard, the range of the manufacturer must be observed.

6.1.6 Requirements on the AC cable to the inverter

- Conductor type: copper wire

- Permissible temperature: at least 90°C (194°F)
- Conductor cross-section: 6 mm² to 16 mm² (10 AWG to 4 AWG)
- The cross-section of the grounding conductor must not be smaller than the cross-section of the other conductors.
- Insulation stripping length: 18 mm (0.7 in)
- The conductors with regards to their ampacity, rated temperatures, operating conditions and power loss must be made in accordance with the local standards and the *National Electrical Code*® ANSI/NFPA 70. If the manufacturer (SMA Solar Technology AG) requires a higher conductor cross-section than the standard, the range of the manufacturer must be observed.
- Information:** In backup mode, the line must be rated for a current of 32 A (for SBSE3.8-US-50 / SBSE4.8-US-50 / SBSE5.8-US-50 / SBSE7.7-US-50) and 48 A (for SBSE9.6-US-50 / SBSE11.5-US-50).

6.2 Enclosure opening

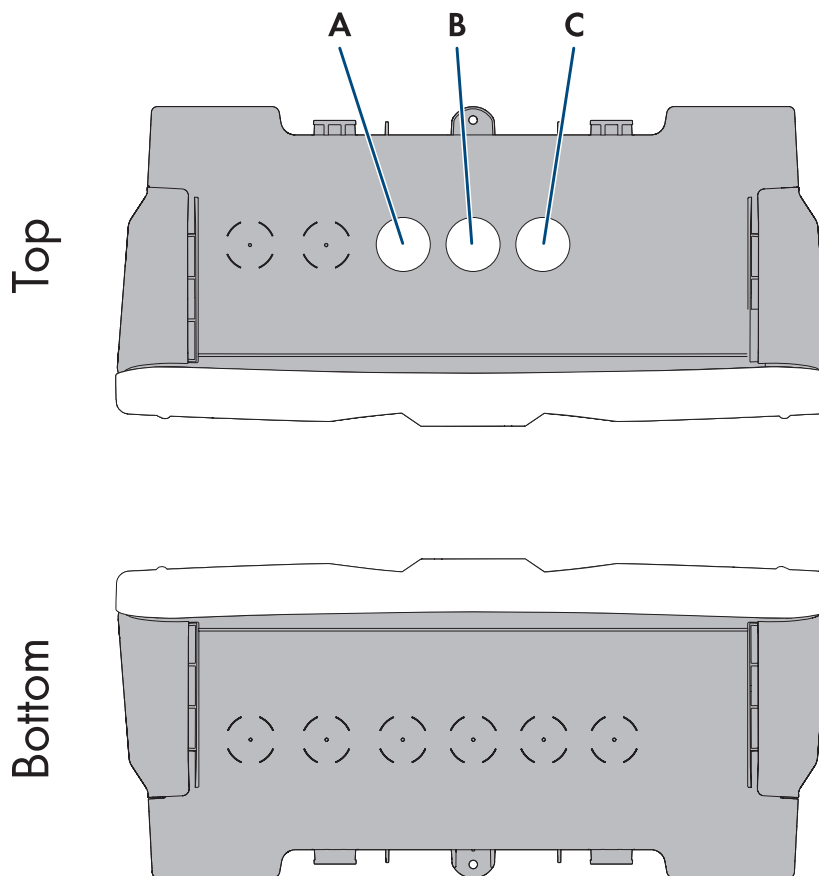

Position	Cable
A	AC cable for connection of backup loads
B	AC cable for the AC connection on the inverter AC cable SPS IN and SPS OUT
C	AC cable for connection to the utility grid

6.3 Overview of the Connection Area

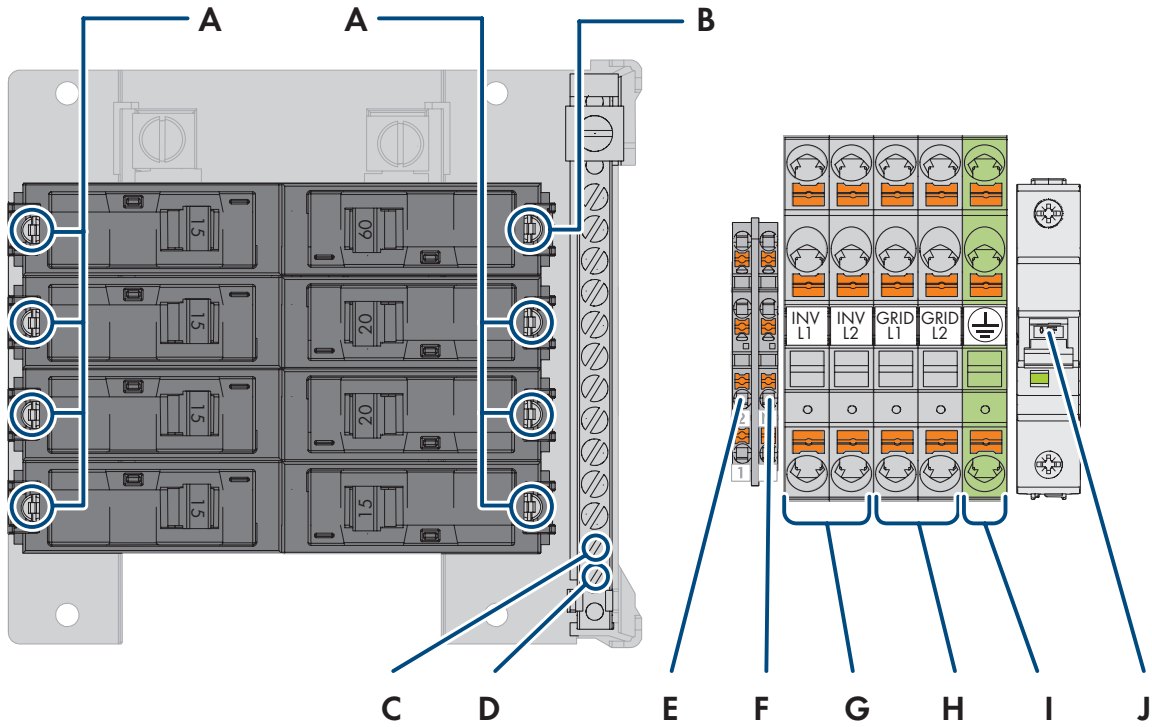

Position	Designation
A	Loads connection
B	Connection of 60 A miniature circuit breaker for sub-distribution
C	Connections for the AC cables N to the utility grid
D	Connections for the AC cables N to the inverter
E	Connection for the AC cable SPS IN
F	Connection for the AC cable SPS OUT
G	Connections for the AC cables L1 and L2 to the inverter
H	Connections for the AC cables L1 and L2 to the utility grid
I	Connection for the grounding cable from the utility grid and the inverter
J	6 A pre-fusing of the monitoring relay

6.4 Removing the grounding conductor connection on the inverter

Procedure:

1. Disconnect the inverter from voltage sources (see inverter manual).
2. If present, remove the grounding conductor connection between **N** and the busbar \ominus . To do this, unlock the terminal with a flat-blade screwdriver (3.5 mm).

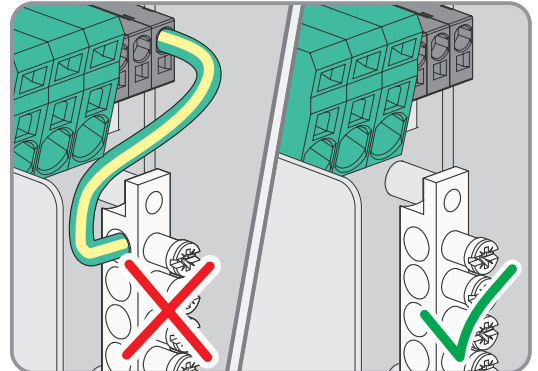

6.5 Connecting the connections to the automatic transfer switching device

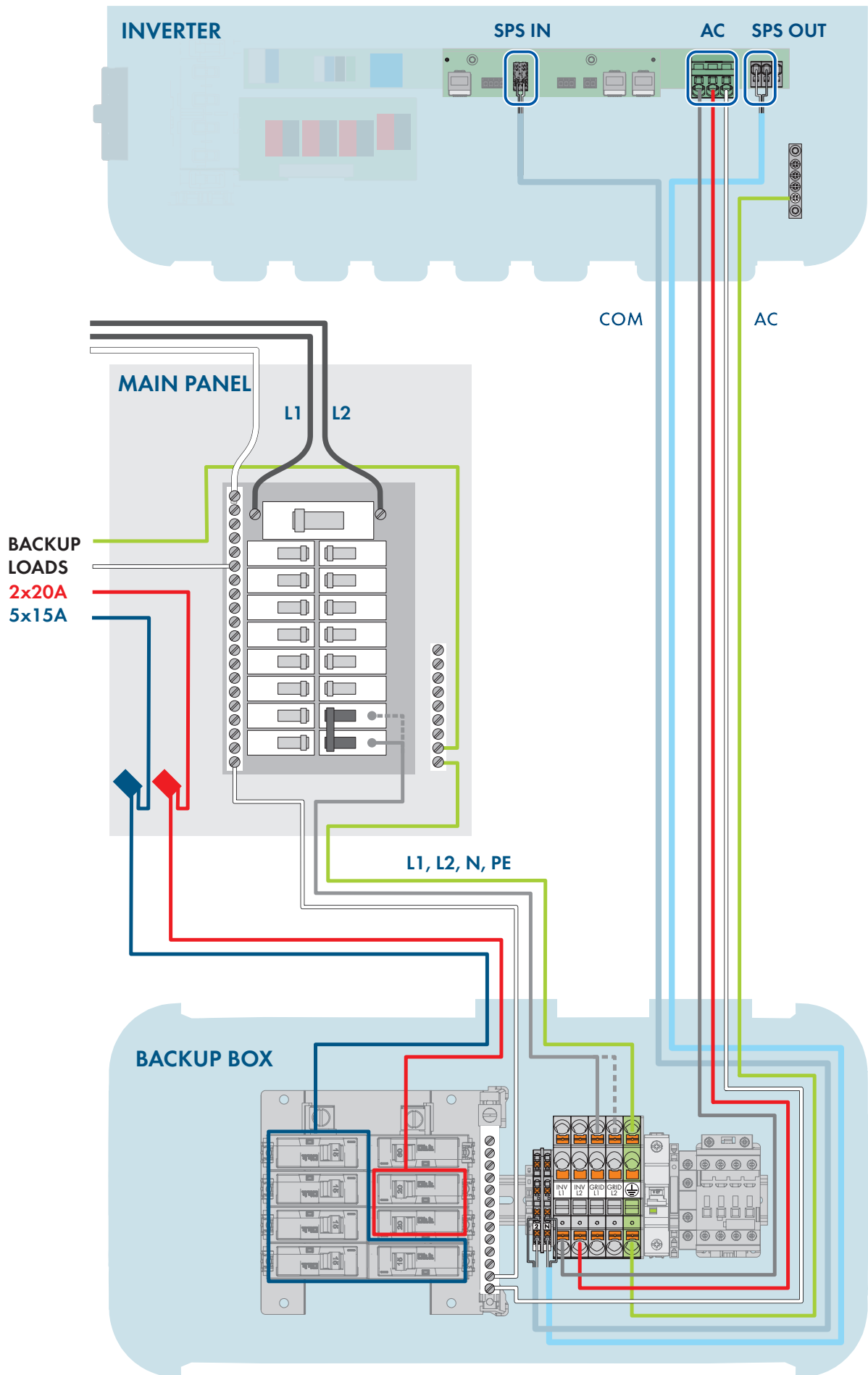

Figure 4: Circuitry overview with Main Panel

Requirement:

- The lid of the automatic transfer switching device has been opened or removed.
- The installation cover of the automatic transfer switching device has been removed.

Procedure:

1. Disconnect the inverter from all voltage sources. See inverter manual.
2. Disconnect the AC fuse.
3. Connect the **PE** of the utility grid to the lower connection \oplus on the automatic transfer switching device. To do this, unlock the terminal with a flat-blade screwdriver (5.5 mm).

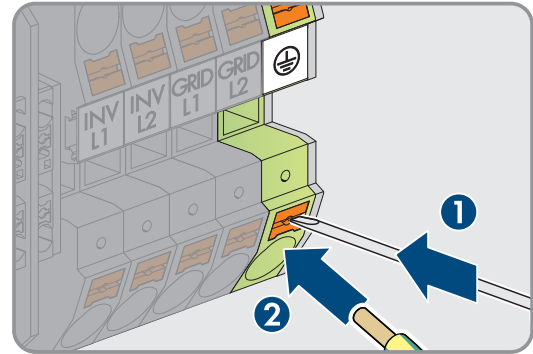

4. Connect the **PE** from the inverter to the upper connection \oplus on the automatic transfer switching device. To do this, unlock the terminal with a flat-blade screwdriver (5.5 mm).

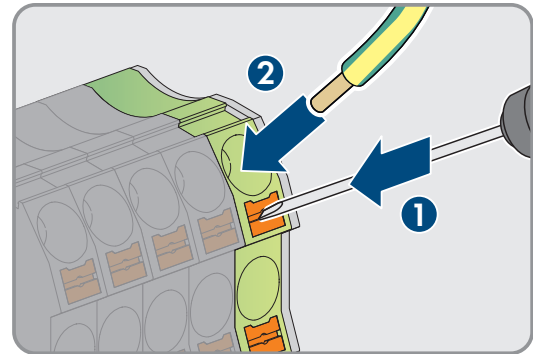

5. Connect **L2** to the utility grid at the **GRID L2** terminal on the automatic transfer switching device, as labeled. To do this, unlock the terminals with a flat-blade screwdriver (5.5 mm).

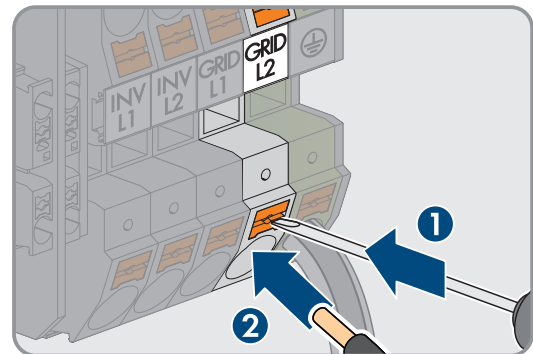

6. Connect **L1** to the utility grid at the **GRID L1** terminal on the automatic transfer switching device, as labeled. To do this, unlock the terminals with a flat-blade screwdriver (5.5 mm).

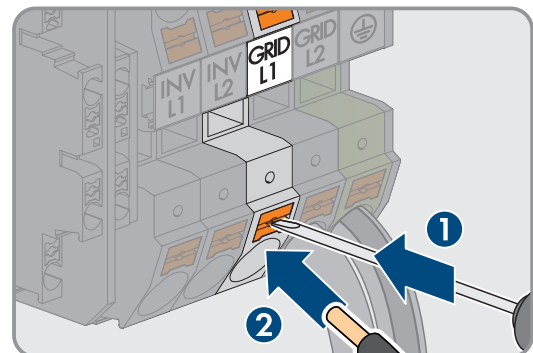

7. Connect conductor **L2** for the backup loads to the **INV L2** terminal on the automatic transfer switching device. To do this, unlock the terminals with a flat-blade screwdriver (5.5 mm).

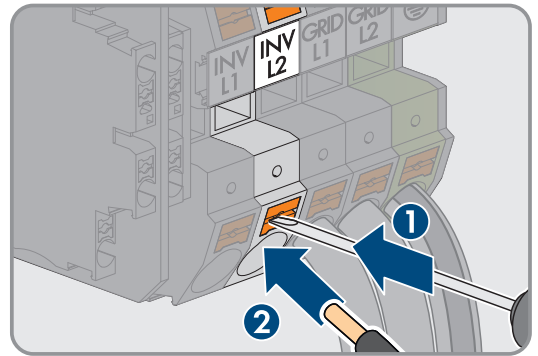

8. Connect conductor **L1** for the backup loads to the **INV L1** terminal on the automatic transfer switching device. To do this, unlock the terminals with a flat-blade screwdriver (5.5 mm).

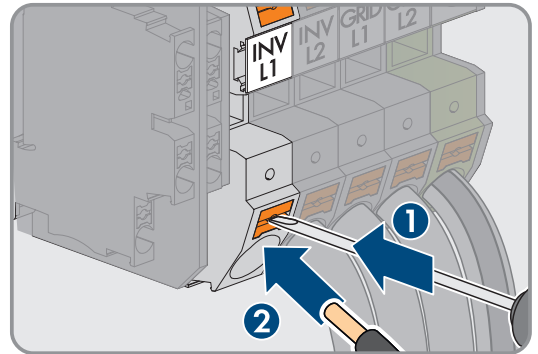

9. Connect the **SPS OUT** AC cable to **L** and **N** on the automatic transfer switching device, as labeled. To do this, unlock the terminals with a flat-blade screwdriver (3.5 mm).

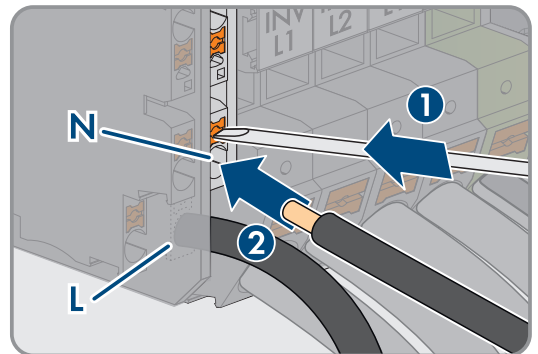

10. Connect the AC cable **SPS IN** to **1** and **2**, as labeled. To do this, unlock the terminals with a flat-blade screwdriver (3.5 mm).

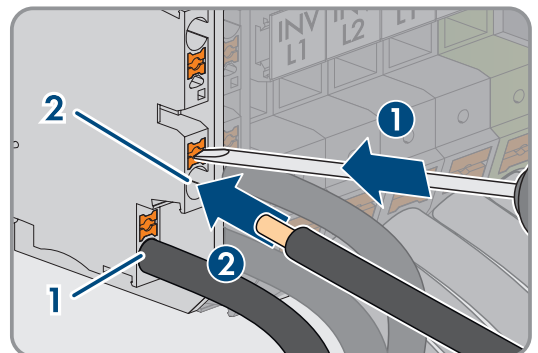

11. Connect the conductor **N** of the utility grid to the terminal block of the automatic transfer switching device.

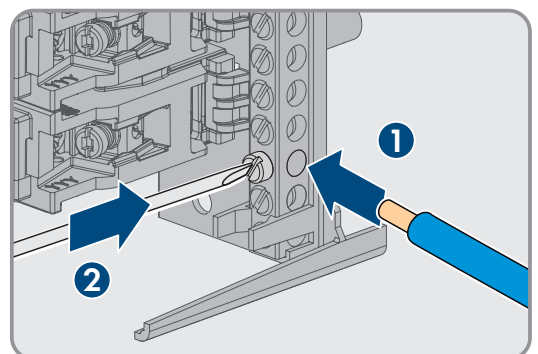

12. Connect the conductor **N** of the inverter to the terminal block of the automatic transfer switching device.

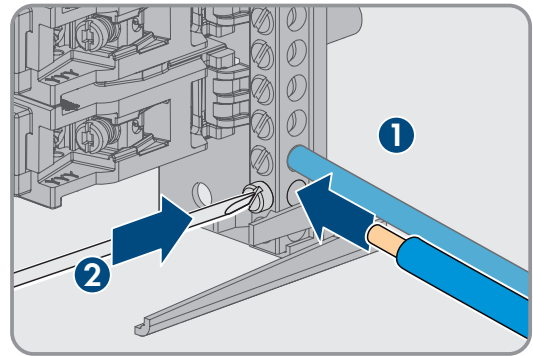

13. Connect the conductor **L** for the loads to the automatic transfer switching device.

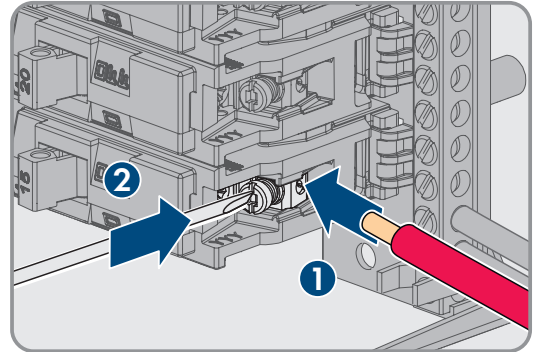

14. Ensure that the pre-fuse of the monitoring relay is switched on.

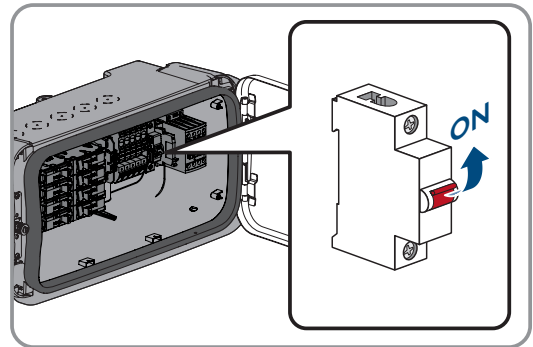

15. Tug lightly to ensure that all conductors are secured in the terminals.

Also see:

- Optional: Remove lid ⇒ page 16

7 Operation

7.1 Operation with SMA 360° App

7.1.1 Updating the inverter firmware version with SMA 360° App

i Before commissioning the product, the firmware version of the inverter must be updated to version $\geq 3.12.15.R$.

Requirements:

- An update file with the desired firmware of the product must be available on the smart terminal device. You can download the update file, for example, from the product page under www.SMA-Solar.com.
- The SMA 360° app (firmware version ≥ 2.1) must be installed and opened on the smart terminal device (e.g., smartphone).

Procedure:

1. In the main menu, navigate to [**Setup**] and then [**Manual update**].
2. Select update file via [**Select file**].
3. When requested by the app, scan the QR code on the cover of the inverter.
4. Follow the instructions in the app and perform the manual firmware update. Keep in mind that this process can take about 5 minutes.

7.1.2 Setting Parameters for Automatic Backup Operation Using SMA 360° App

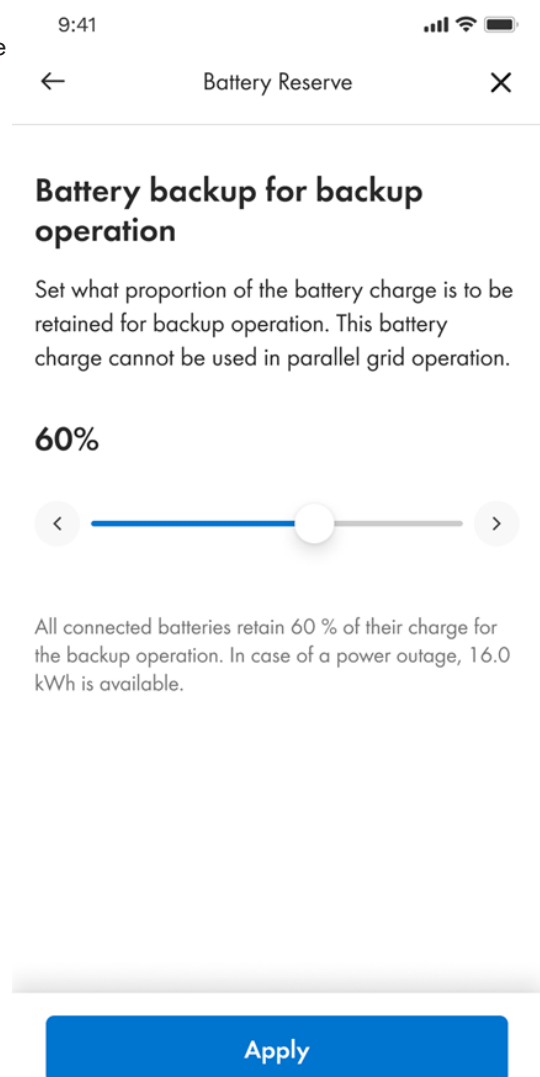

1. Start commissioning with the SMA 360° app and continue until it comes to setting **Backup operation**.
2. Select **Backup operation** and then **Backup Select operation**.

- Once energy management has been activated and a battery is available, use the slider to set the desired value for battery charge that is to be retained for backup operation.



- Backup operation** has been set.

4. Complete commissioning.

✓	Grid connection	→
✓	Grid Management Services	→
✓	Energy Meter	→
✓	Safety	→
✓	Battery	→
✓	Energy Management	→
✓	Backup operation	↓
✓	Type of Backup Backup Secure operation	
✓	Battery backup for backup operation 20 %	

7.2 Operation via User Interface

7.2.1 Updating the inverter firmware version

Before commissioning the product, the firmware version of the inverter must be updated to version $\geq 3.12.15.R$ (see product manual).

7.2.2 Changing parameters

The parameters of the inverter are set to certain values by default. You can change the parameters to optimize the performance of the inverter.

This section describes the basic procedure for changing parameters. Always change parameters as described in this section.

Requirements:

- The user interface of the inverter must be open and you must be logged in.
- Changes to grid-relevant parameters must be approved by the responsible grid operator, and can only be made as an **installer**.

Procedure:

1. Choose the product in the focus navigation.
2. Select the menu **Configuration**.

3. Select the menu item **Parameters**.
4. Call up the parameter via the search function or navigate to the parameter.
5. Change the parameter value.
6. Click on [**Save**].

7.2.3 Setting parameters for automatic backup operation

Procedure:

Automatic backup operation must be set in the **Operation.BckTyp** parameter (**Configuration of the backup type**) so that the automatic transfer switching device can automatically switch to automatic backup operation in the event of a grid failure.

Ensure that the parameters are set to the default values recommended by SMA Solar Technology AG Changing parameters.

Parameter	Name	Settings	Description
Operation.BckTyp	Configuration of the backup type	Off Automatic backup operation Backup Secure Operation	Configure the Automatic backup operation to enable the automatic transfer switching device to switch to automatic backup operation mode automatically in the event of a grid failure.
Operation.BckSwOnDI	Minimum duration of grid fault for start of automatic backup operation	0 s to 600 s	Time after a grid failure before switching to automatic backup operation. 5 s is set by default.
Operation.BckSwOffDI	Minimum duration of grid recovery for deactivation of backup operation	1 s to 600 s	Time after restoration of the AC grid before switching back to parallel grid operation. 300 s is set by default.
Operation.BckCbSwDI	Interruption of load supply during the transition from automatic backup to feed-in operation	0 s to 60 s	Time during which backup loads are not supplied while switching from automatic backup operation to parallel grid operation. 5 s is set by default.
Operation.ManRstr.IsOn	Manual restart activated	Yes No	Select Yes to activate manual restart.

Parameter	Name	Settings	Description
Operation.ManRstr.ManRstrBckSc	Activation of manual restart after repeated occurrence of short-circuit faults in backup secure /automatic backup operation	On Off	<p>On: The inverter remains in fault mode.</p> <p>Off: In the event of a fault during automatic backup operation, the inverter repeatedly attempts to restart until the fault is cleared.</p> <p>On is set by default.</p> <p>The parameter settings must be made differently depending on the country-specific standards.</p>
Bck.Vset	Voltage in backup operation	Enter the value in volts (V)	Voltage during backup operation, depending on the inverter.

7.3 Testing automatic backup operation

Requirements:

- The automatic transfer switching device for automatic backup operation must be connected.
- The inverter must be commissioned (see product manual).
- The **Automatic backup operation** parameter must be configured during commissioning.
- Parallel grid operation must be configured.
- The battery must be sufficiently charged or there must be sufficient PV energy available.

Procedure:

1. To simulate a grid failure, switch off the central miniature circuit breaker (pre-meter fuse) or the fuse of the automatic transfer switching device in the Main Panel.
2. Wait for the time set in the parameter **Operation.BckSwOnDI (Minimum duration of grid fault for start of automatic backup operation)**.
 - The automatic transfer switching device switches to automatic backup operation with an audible click.
 - When the time set in the parameter **Operation.BckSwOnDI (Minimum duration of grid fault for start of automatic backup operation)** has elapsed, all loads in the automatic backup circuit should be supplied with electric current.
3. Switch on the central miniature circuit breaker (pre-meter fuse) in the junction box again.
4. Wait for the time set in the parameter **Operation.BckSwOffDI (Minimum duration of grid recovery for deactivation of backup operation)**.
 - The automatic transfer switching device switches to parallel grid operation with an audible click.

8 Closing the enclosure

Requirements:

- The automatic transfer switching device and inverter must be de-energized.

Procedure:

1. Switch on the pre-fuse for the grid monitoring relay (see Section 6.3, page 22).
2. Fasten the installation cover. To do this, tighten the 4 screws (TX20) for fastening the installation cover.
3. Close the lid of the enclosure. The lid engages audibly when closing.

9 Troubleshooting

Behavior	Possible causes and remedy
The residual-current device trips.	<ul style="list-style-type: none"> The grounding conductor connection between N and the busbar  in the inverter has not been removed. Remove grounding conductor connection (see Section 6.4, page 23).
After the automatic transfer switching device has switched to automatic backup operation with an audible click, the loads in the automatic backup circuit are not supplied with electric current.	<ul style="list-style-type: none"> Check whether the contactors have switched. Contact Service if the contactors have switched and the loads in the automatic backup circuit are still not supplied with electric current. The inverter carries out a cyclical insulation test at least every 24 h during the night. If the system is in automatic backup operation during the insulation test, the backup loads are not supplied for a short time until the insulation test has been completed successfully.
The automatic transfer switching device does not switch to automatic backup operation in the event of a grid failure. The connected backup loads are not supplied with electric current.	<ul style="list-style-type: none"> Check the fuses of the automatic transfer switching device. There is not enough PV energy available or the battery is not sufficiently charged. Check the battery. The Operation.BckTyp parameter (Configuration of the backup type) is not set to Automatic backup operation. Set the parameter Operation.BckTyp (Configuration of the backup type) to Automatic backup operation Changing parameters. A firmware version of at least 3.12.15.R is required to be able to set the parameters for backup operation. If a firmware version lower than this is installed, update the firmware of the inverter. The time set in the parameter Operation.BckSwOnDI (Minimum duration of grid fault for start of automatic backup operation) has not yet elapsed. Check the time set in the parameter and adjust if necessary Changing parameters. The SPS IN and SPS OUT cables are not connected to the inverter correctly or have been swapped over. Check the cable connections of SPS IN and SPS OUT.
If external factors lead to an impermissibly high temperature of the closure system of the automatic transfer switching device, the lid of the automatic transfer switching device can no longer be opened.	<ul style="list-style-type: none"> Remove the external heat source and wait until the automatic transfer switching device is back within the permitted temperature range. The lid can then be opened again.
The LED on the automatic transfer switching device does not light up even though the utility grid is available.	<ul style="list-style-type: none"> The pre-fuse of the monitoring relay is switched off. Switch the fuse back on. The monitoring relay is damaged.
Automatic backup operation continues after a grid failure and transfer, even after grid power is restored.	<ul style="list-style-type: none"> The B6 pre-fuse under the protective cover (see Section 6.3, page 22) must be switched on.

10 Decommissioning the Product

Procedure:

1. Disconnect the inverter from voltage sources (see inverter manual).
2. Switch off the battery (see manual from the battery manufacturer).
3. Disconnect the automatic transfer switching device from voltage sources.
4. Open the lid of the automatic transfer switching device. To do this, press on the left side of the box.
5. Remove the installation cover of the automatic transfer switching device. To do this, loosen the 4 screws (TX20) for fastening the installation cover using a suitable tool.
6. Remove the connected cables from the automatic transfer switching device.
7. Pull the cable out of the enclosure opening holes.
8. Loosen the screw for fastening the automatic transfer switching device on the wall mounting bracket.
9. Remove the automatic transfer switching device from the wall mounting bracket.
10. Use a suitable screwdriver to loosen the screws securing the wall mounting bracket and remove the washers.
11. Remove the wall mounting bracket.

11 Disposal

The product must be disposed of in accordance with the locally applicable disposal regulations for waste electrical and electronic equipment.

12 Technical Data

12.1 General Data

Width x height x depth (with wall mounting bracket)	506 mm x 260 mm x 236 mm (19.9 in x 10.2 in x 9.3 in)
Width x height x depth (without wall mounting bracket)	506 mm x 260 mm x 226 mm (19.9 in x 10.2 in x 8.9 in)
Weight	6.09 kg (13.4 lbs)
Length x width x height of the packaging	600 mm x 400 mm x 320 mm (23.6 in x 15.7 in x 12.6 in)
Degree of protection (as per NEMA)	Type 3R
Operating temperature range	-40 °F to +131 °F (-40 °C to +55 °C)
Storage temperature range	-40 °F to +158 °F (-40 °C to +70 °C)
Maximum permissible value for relative humidity (non-condensing)	0% to 100%
Maximum operating altitude above mean sea level (MSL)	3000 m (9843 ft)
Grid configurations	240 V split-phase system, 208 V wye connection

12.2 Parallel grid operation

Input voltage	240 V / 208 V
AC grid frequency	60 Hz
Maximum pre-fuse on the grid side	60 A
Self-consumption	< 1 W

12.3 Automatic backup

Compatible with the following inverters	SBSE3.8-US-50 / SBSE4.8-US-50 / SBSE5.8-US-50 / SBSE7.7-US-50 / SBSE9.6-US-50 / SBSE11.5-US-50
Rated power for SBSE3.8-US-50 / SBSE4.8-US-50 / SBSE5.8-US-50 / SBSE7.7-US-50:	3840 W
Rated power for SBSE9.6-US-50 / SBSE11.5-US-50:	5760 W
Output power / Output apparent power < 100 ms ¹⁾	150% of rated power
Output power / Output apparent power < 30 s ¹⁾	125% of rated power
Nominal AC voltage	120 V

¹⁾ Refers to the short-term overload capability of the inverter.

Active power limit AC frequency	60 Hz
Switching mode	automatic

12.4 Switchover times (adjustable parameters)

Interruption of load supply during the transition from automatic backup to feed-in operation	0 s to 60 s (default: 5 s)
Minimum duration of grid fault for start of automatic backup operation	0 s to 600 s (default: 5 s)

13 Contact

If you experience any technical problems with our products, please contact the Service. The following data is required in order to provide you with the necessary assistance:

- Device type
- Serial number
- Detailed description of the problem



<https://go.sma.de/service>

ENERGY
THAT
CHANGES



www.SMA-Solar.com

