



Maintenance Manual
SUNNY CENTRAL and Accessories



Legal Provisions

The information contained in these documents is the property of SMA Solar Technology AG. Any publication, whether in whole or in part, requires prior written approval by SMA Solar Technology AG. Internal reproduction used solely for the purpose of product evaluation or other proper use is allowed and does not require prior approval.

Disclaimer

The general terms and conditions of delivery of SMA Solar Technology AG apply.

The content of these documents is monitored in an ongoing manner and updated when necessary. However, discrepancies may still arise. We assume no liability for completeness of the information. You can obtain the current version on the Internet at www.SMA.de or from the regular sales channels.

Warranty and liability claims for damage of any kind is excluded when this damage is caused by one or more of the following factors:

- Transport damage
- Incorrect or not intended use of the product
- Operating the product in an environment other than the intended one
- Operating the product while failing to observe the safety regulations applicable to the usage site
- Failing to observe the warning and safety notes contained in all documentation relevant to the product
- Operating the product under incorrect safety and protection conditions
- Unauthorized alterations or repairs of the product or the supplied software
- Product malfunctions caused by the effect of attached or neighboring devices which are outside of the legally approved limiting values
- Catastrophes and force majeure
- The use of the software supplied by SMA Solar Technology AG also is subject to the following conditions:
- SMA Solar Technology AG rejects any liability for direct or indirect damage arising from the use of software developed by SMA Solar Technology AG. This also applies to support services rendered or not rendered.
- Supplied software that was not produced by SMA Solar Technology AG is subject to the manufacturer's license and liability agreements.

SMA Factory Warranty

The current warranty regulations are included with your device. You can download the version on the Internet at www.SMA.de or obtain a printed version from the regular sales channels.

Trademarks

All trademarks are recognized, even if not explicitly identified as such. Missing designations do not mean that a product or brand is not a registered trademark.

The *Bluetooth*[®] word mark and logos are registered trademarks owned by Bluetooth SIG, Inc. and any use of these marks by SMA Solar Technology AG is under license.

SMA Solar Technology AG

Sonnenallee 1

34266 Niestetal

Germany

Tel. +49 561 9522-0

Fax +49 561 9522-100

www.SMA.de

E-Mail: info@SMA.de

© 2018 SMA Solar Technology AG. All rights reserved.

Table of Contents

| | | |
|----------|---|-----------|
| 1 | Information on This Manual | 5 |
| 1.1 | Validity | 5 |
| 1.2 | Target Group | 5 |
| 1.3 | Documentations | 5 |
| 1.4 | Spare parts | 5 |
| 1.5 | Additional information | 5 |
| 1.6 | Symbols Used | 6 |
| 2 | security | 7 |
| 2.1 | Safety Information | 7 |
| 2.1.1 | Electrical safety | 7 |
| 2.1.2 | Personnel | 7 |
| 2.1.3 | Torques | 7 |
| 3 | Maintaining the Sunny Central | 8 |
| 3.1 | Identifying the Sunny Central | 8 |
| 3.2 | Reading out Long-term Data and Error Memory | 9 |
| 3.3 | Cleaning the Power Electronics | 9 |
| 3.4 | Maintaining the Air Inlet Filter | 10 |
| 3.4.1 | General Activities | 10 |
| 3.4.2 | Sunny Central 100LV / SC 150 / SC 125LV / SC 200 / 200HE | 11 |
| 3.4.3 | Sunny Central 250 / 250 HE | 12 |
| 3.4.4 | Sunny Central 350 / SC 350 HE | 12 |
| 3.4.5 | Sunny Central 500HE / 560HE / 400HE-11 / 500HE-11 / 630HE-11 | 13 |
| 3.5 | Cleaning the Insect Screens | 13 |
| 3.5.1 | General information on cleaning the insect screen | 13 |
| 3.5.2 | Sunny Central 100 outdoor (older model) | 14 |
| 3.5.3 | Sunny Central 100 indoor /outdoor (new model) | 15 |
| 3.5.4 | Removing the Roof | 16 |
| 3.5.5 | Removing the Kick Plates | 18 |
| 3.5.6 | Removing the Exhaust Air Filter in the Base | 18 |
| 3.6 | Sunny Central 100LV / SC 125LV / SC 150 / SC 200 / 200HE | 19 |
| 3.7 | Sunny Central 250 / 250HE | 20 |
| 3.8 | Sunny Central 350 / SC 350HE | 21 |
| 3.9 | Sunny Central 500HE / 560HE / 400HE-11 / 500HE-11 / 630HE-11 | 22 |
| 3.10 | Sunny Central 400 / 500 / 700 / 1000 / 1120MV | 24 |
| 3.11 | Checking the DC switching device at Sunny Central 400HE-11 /500HE-11 / 630HE-11 | 25 |
| 3.12 | Maintaining the Heat Exchanger | 26 |
| 3.12.1 | Disassembling the Heat Exchanger for Sunny Central 200 / 250 | 26 |
| 3.12.2 | Disassembling the Heat Exchanger of Sunny Central 400HE-11 / 500HE-11 /630HE-11 | 30 |
| 4 | Covers and Lockings | 33 |
| 4.1 | Checking the Function of the Internal and External Emergency Switch | 33 |
| 4.2 | Checking the Door Contact Switch | 34 |

| | | |
|-----------|---|-----------|
| 4.3 | Checking the seals | 35 |
| 4.4 | Checking the locking devices and hinges | 35 |
| 5 | Maintaining the Inside of the Switch Cabinet | 36 |
| 5.1 | Checking the Inside of the Switch Cabinet for Contamination | 36 |
| 5.2 | Cleaning the Power Unit of the Heat Sink | 37 |
| 5.3 | Cleaning the EVR Resistor | 38 |
| 5.4 | Checking the Power Cable Connections | 39 |
| 5.5 | Checking the Warning Messages | 39 |
| 5.6 | Checking the Fans and Thermostats | 40 |
| 5.7 | Checking the heating element and the hygrostat | 41 |
| 5.8 | Replacing the Battery of the Sunny Central Control | 42 |
| 6 | Checking the Protective Devices | 44 |
| 6.1 | General Information on Protective Devices | 44 |
| 6.2 | Checking the Residual Current Device in the SC 100 | 44 |
| 6.3 | Checking the Circuit Breaker | 45 |
| 6.4 | Checking the DC Main Switch | 46 |
| 6.4.1 | Circuit Breaker and Load-Break Switch | 46 |
| 6.5 | Checking the Fuses and Disconnectors | 48 |
| 6.6 | Checking the surge arresters | 48 |
| 6.6.1 | Information for Checking the Surge Arrester | 48 |
| 6.6.2 | Checking the Dehn Guard | 49 |
| 6.6.3 | Checking the Blitzductor | 49 |
| 6.7 | Maintaining the GFDI | 50 |
| 6.8 | Maintaining the Soft Grounding | 50 |
| 7 | Additional Information on Sunny Central 100 | 51 |
| 7.1 | Checking the Transformer and Sinusoidal Filter | 51 |
| 7.2 | Checking the Cable Feed of the SC 100outdoor | 52 |
| 8 | Additional Information on MV Stations | 53 |
| 9 | Maintaining the Sunny String-Monitor | 54 |
| 10 | Maintaining the Sunny String Monitor-Cabinet | 57 |
| 11 | Maintenance of Sunny String-Monitor SSM24-11 | 60 |
| 12 | Maintaining the Sunny Main Box | 63 |
| 13 | Contact | 64 |

1 Information on This Manual

1.1 Validity

This document describes how to maintain the Sunny Central indoor and outdoor central inverters. It is valid for all switch cabinet versions, the MV stations as well as their accessories such as Sunny String-Monitor, Sunny String Monitor-Cabinet and Sunny Main Box.

1.2 Target Group

This document is for installers and operators of a Sunny Central. It includes a description of the maintenance of the Sunny Central, the intervals and the maintenance work. The appropriate maintenance protocol describes the replacement intervals of the components that need to be replaced.

1.3 Documentations

The documents listed below are included in the scope of delivery for your Sunny Central. The following information is contained in these documents.

- | | |
|-------------------------|---|
| • Installation Manual | Setup and installation of the Sunny Central |
| • User Manual | How to operate the Sunny Central and Sunny Central Control |
| • Circuit diagrams | Sunny Central circuit diagrams including torques and the equipment list with all article numbers. |
| • Technical data sheets | Technical data pertaining to the Sunny Central |
| • Commissioning Report | Check list for commissioning |
| • Maintenance Manual | Maintenance of the Sunny Central and its accessories |
| • Maintenance Report | Checklist for maintenance |

1.4 Spare parts

You can find the article number of the individual spare parts in the equipment list in the circuit diagram. You can obtain the article numbers from SMA Solar Technology.

1.5 Additional information

For more information on maintenance activities of the DC switchgear, please visit www.abb.com:

| Component | Document Number |
|----------------------|-----------------|
| DC switchgear: T-Max | 1SDH000707R0001 |

1.6 Symbols Used

The following four types of safety notices and general information are used in this document:

DANGER

"DANGER" indicates a hazardous situation which, if not avoided, results in death or serious injury!

WARNING

"WARNING" indicates a hazardous situation which, if not avoided, can result in death or serious injury!

CAUTION

"CAUTION" indicates a hazardous situation which, if not avoided, can result in minor or moderate injury!

NOTICE

"NOTICE" indicates a situation which, if not avoided, can result in property damage!

Information

Information provides tips that are valuable for the optimal operation of the product.

2 security

2.1 Safety Information

2.1.1 Electrical safety

High voltages are present in the device.

All work on the Sunny Central must be carried out exactly as described in the maintenance manual and all safety precautions must be observed. Observe all safety information in the Sunny Central installation manual. Do not touch the live components of the Sunny Central or the medium-voltage grid. Observe all safety regulations regarding the medium-voltage grid.

Damage to the Sunny Central, e.g. defective cables or damaged enclosure, can lead to death by electric shock or fire!

Only use the Sunny Central when it is in a technically faultless condition and safe to operate. Operate the Sunny Central only if there are no visible damages. Regularly check the Sunny Central for visible damage. Ensure that all external safety features are freely accessible at all times, and that they are regularly tested for correct functionality!

Electrostatic discharge can damage the Sunny Central.

When working on the Sunny Central and when handling the components observe all ESD safety regulations. Discharge electrostatic charge by touching the grounded Sunny Central enclosure. before handling electronic components!

2.1.2 Personnel

Only qualified technical personnel may perform work on the MV station. Qualified means that the personnel must possess training relevant to the task performed and must be familiar with the content of this manual.

2.1.3 Torques

Always observe the torques of the individual components. You will find the torques in the circuit diagram of the respective device. If you cannot find the corresponding torques in the device's documentation, contact the Sunny Central Service.

3 Maintaining the Sunny Central

The Sunny Central, the string monitoring units and the communication units must be maintained at regular intervals. Maintenance includes the following activities:

- Inspection of wearing parts, and replacement if necessary
- Functional test of components
- Inspection of contact joints
- Cleaning of cabinet interior, if necessary

A maintenance protocol is enclosed with every Sunny Central. The maintenance protocol describes the maintenance work to be carried out and the maintenance interval recommended by SMA Solar Technology.

i Maintenance intervals

The maintenance interval depends on the location and the ambient conditions. A device installed in an environment with very dusty ambient air requires more frequent maintenance than recommended. The maintenance interval is to be adapted accordingly.

3.1 Identifying the Sunny Central

You can identify the Sunny Central using the type label. The type label is located on the inside of the Sunny Central's door. In addition, the serial number (A) is located on the front side of the device.

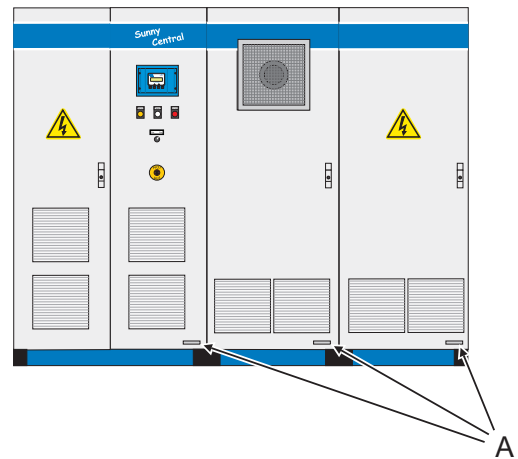

3.2 Reading out Long-term Data and Error Memory

In order to ensure smooth plant operation, all plant components must be optimally matched to one another. Deviations from the optimum operation can result in yield losses and thus in a reduction of the plant's profitability.

Even though there are - depending on the plant communication - several features which issue a warning to the plant operator in case of string failure or malfunctions of the inverter, a regular check of the plant operation is necessary to recognize possible failures which have no alarm function. In addition, the operation of the plant can be improved by evaluating the system data.

Depending on the size of the plant, the error memory of the central inverter and the long-term data from the data logger should be evaluated at least once a month. Proceed as described in the inverter user manual.

3.3 Cleaning the Power Electronics

⚠ DANGER

Danger to life due to electric shock or burns by touching live components

- Only work on the device when it is switched off and voltage-free.

The power electronics of the Sunny Central inverters is considerably well-protected and thus requires almost no maintenance work. Only carry out a visual inspection and clean the circuit boards with a soft brush or a vacuum cleaner with a soft top part if there are dust deposits. The cleaning equipment must be anti-static and ESD-compliant. Do not use any hard or coarse brushes. Using pressurized air is prohibited.

3.4 Maintaining the Air Inlet Filter

3.4.1 General Activities

⚠ DANGER

Danger to life due to electric shock or burns by touching live components

- Only work on the device when it is switched off and voltage-free.

Cleaning or replacing the filter pads in the air inlet filters

This section describes how to disassemble and clean the ventilation grids as well as how to replace the corresponding air filter pads. Depending on the switch cabinet type and model, ventilation grids which have filter pads must be maintained. The filter pads must be cleaned and replaced, if the degree of pollution is too high. The Sunny Central 100 only has ventilation grids without air filter pads.

Disassembling and installing the ventilation grids with the appropriate filter pads

1. Slightly lift the top part of the ventilation grid by using a screwdriver and pull the grid together with the top part forward.
The frame of the ventilation grids is securely attached to the switch cabinet's door and cannot be removed.
2. Remove the filter pads
The filter pad is in a cutout in the top part of the ventilation grid.
3. If the filter pad needs to be replaced, you can order it from SMA:
Article number 65-102011
4. Insert the filter pad.
During mounting, the white side must point outwards and the bluish side to the inside of the switch cabinet.

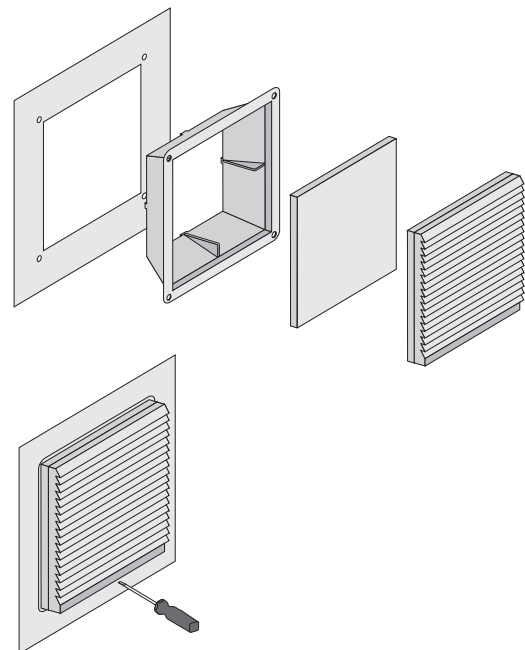

i Smaller filter pads

There is no separate article number for the small filter pads which are installed in the older version of the Sunny Central 500; they have to be cut out from the large filter pads.

Cleaning the filter pads

- Clean with water (up to approx. 40 °C; you can also additionally use commercially available mild detergents).
- Tap or vacuum the filter material, or carefully use pressurized air to remove the contamination.
- For dust containing grease, you should rinse with warm water and additionally use degreaser. The air filter pad may not be cleaned with strong water jet or wrung out.
- As soon as the air filter pads are cleaned and dried, put them back into the frame.

Cleaning the ventilation grids

- The grids can be cleaned using a paintbrush, vacuum, or applying pressurized air

i Position of the ventilation grids

The following sections illustrate the exact position and size of the individual ventilation grids.

3.4.2 Sunny Central 100LV / SC 150 / SC 125LV / SC 200 / 200HE

The switch cabinets of type SC 100LV, SC 150, SC 125 LV and SC 200 are mostly identical in construction and equipped with four large air inlet filters (A).

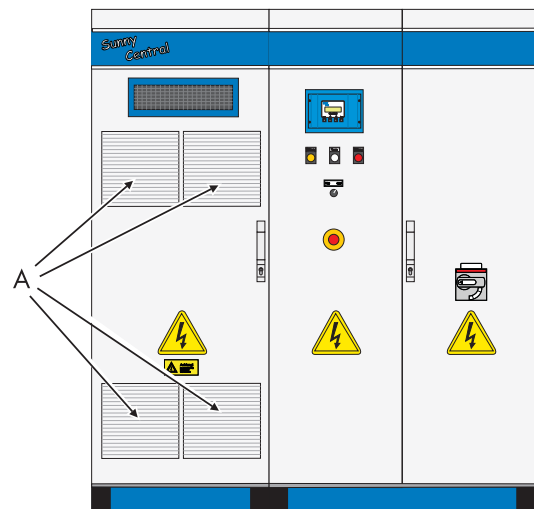

3.4.3 Sunny Central 250 / 250 HE

The switch cabinet of the SC 250 is equipped with six large (A) air inlet filters. The switch cabinets of the new series have four further air inlet filters in the AC cabinet.

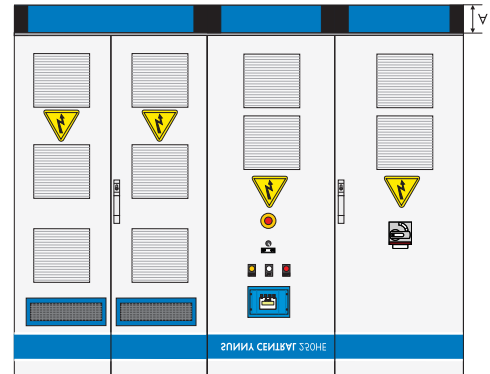
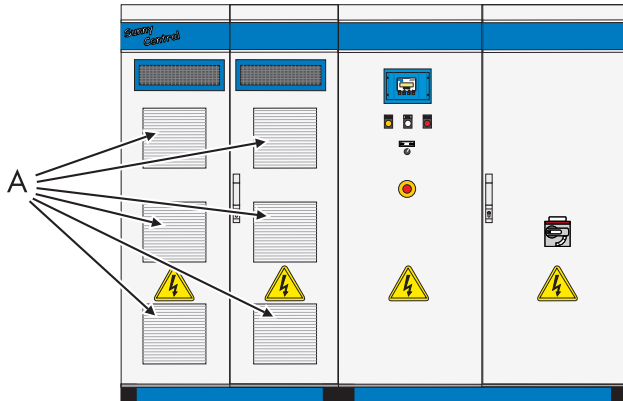

3.4.4 Sunny Central 350 / SC 350 HE

The switch cabinet of the SC 350 is equipped with eight large (A) air inlet filters.

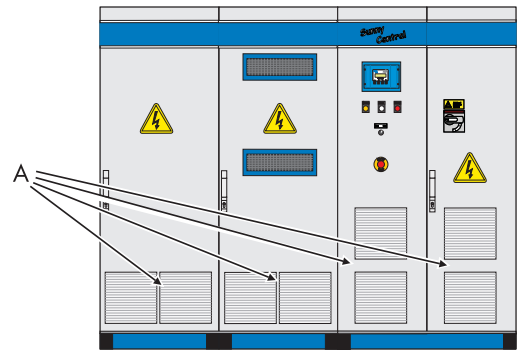

3.4.5 Sunny Central 500HE / 560HE / 400HE-11 / 500HE-11 / 630HE-11

Depending on the design, the switch cabinet of the SC 500HE is equipped with two small air inlet filters (A) and six large air inlet filters (B) or only eight large air inlet filters (B). Only in this model, the switch cabinet of the SC 560HE is equipped with eight large air inlet filters.

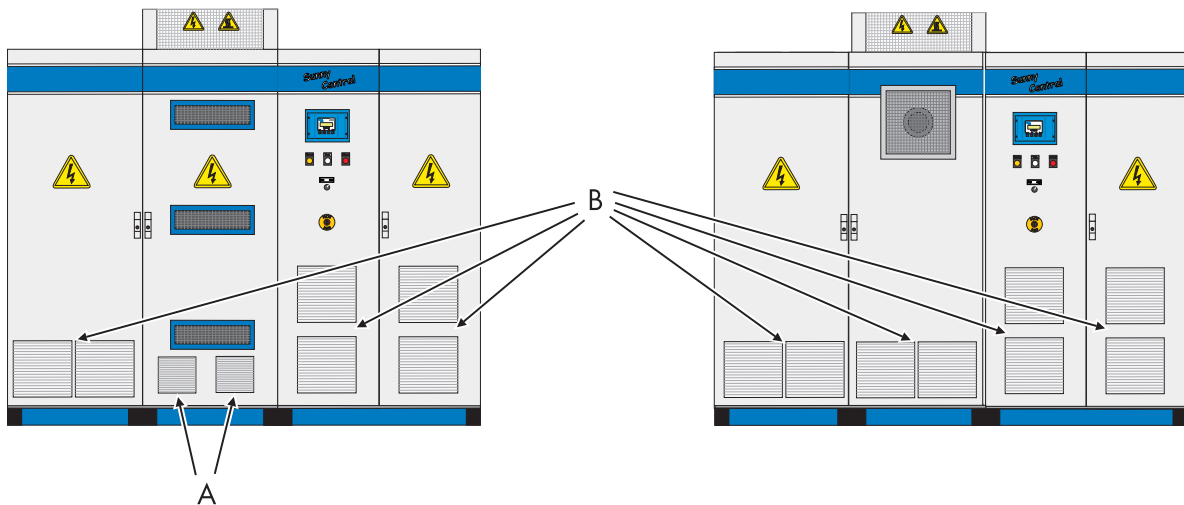

3.5 Cleaning the Insect Screens

3.5.1 General information on cleaning the insect screen

Cleaning the insect screens at the ventilation openings

This section describes how to clean the insect guards at the ventilation openings.

i Exchanging the protective grids

Exchanging the protective grids is only necessary in case of damage.

⚠ DANGER

Danger to life due to electric shock or burns by touching live components

- Only work on the device when it is switched off and voltage-free.

Depending on the switch cabinet type and model, the insect guards on the roof and in the base must be cleaned, in the doors of the inverter cabinets and back sides of the doors. The air for cooling the power units is drawn through and blown out through these insect guards.

The guards can be cleaned using a paintbrush, or handheld brush or by vacuuming, or applying pressurized air.

Cleaning fine guards using pressurized air is prohibited. They are designed thinner and are used for finger protection. Such protective grids are installed on the rear of the switch cabinets.

i Position of the protective grids

The following examples illustrate the exact position and size of the individual protective grids..

3.5.2 Sunny Central 100 outdoor (older model)

The switch cabinet of the SC 100 is equipped with a protective grid in the base. The cooling air is drawn in through the filter in the base and blown out through the protective plate on the back panel of the inverter.

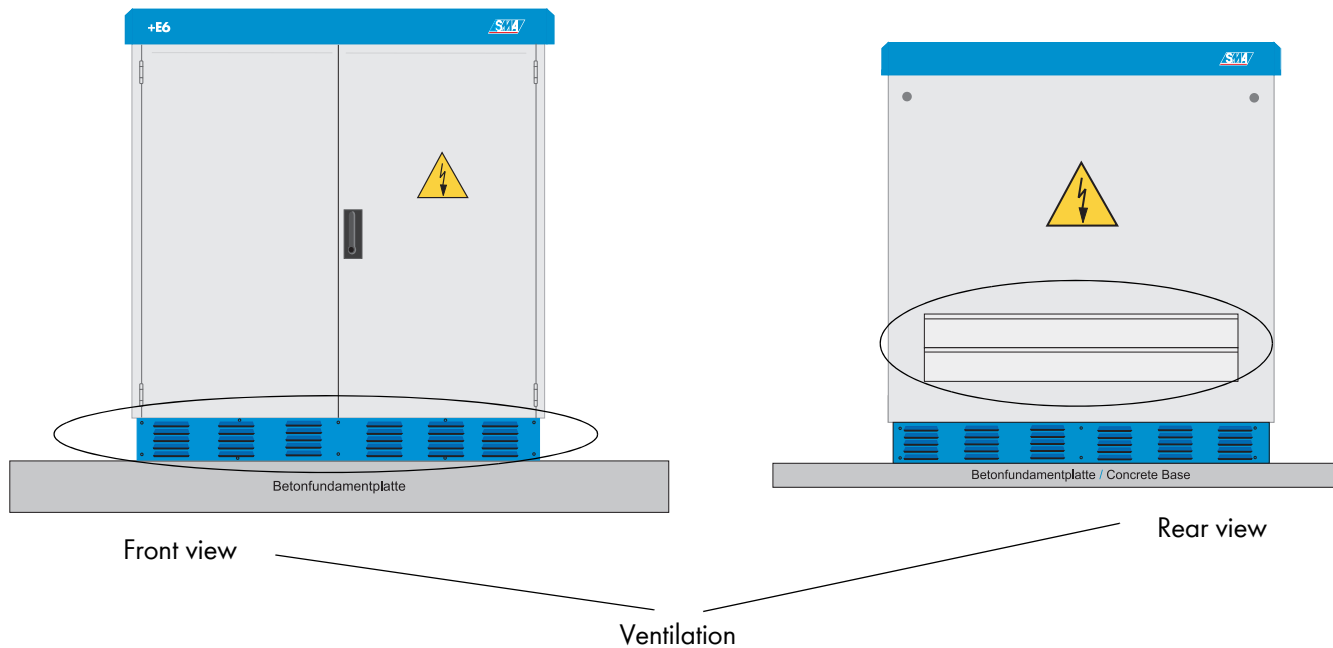

3.5.3 Sunny Central 100 indoor /outdoor (new model)

Both cabinets have large-meshed protective grids (A) in the roof and one in the base.

View of the SC 100 ventilation

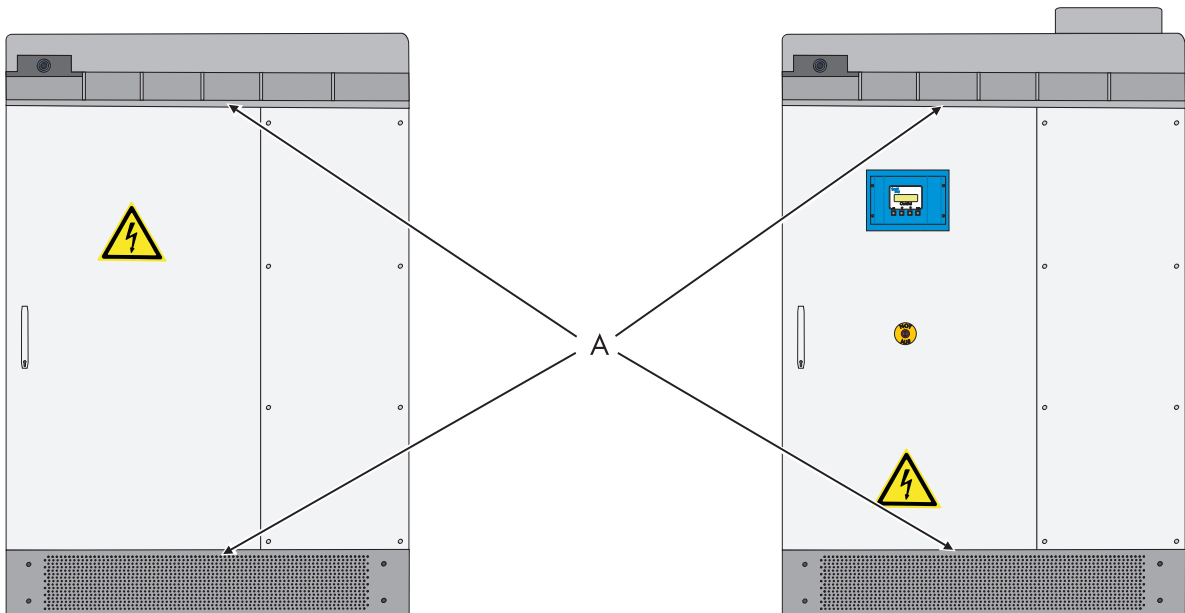

The air is drawn through the roof. In the outdoor version, the air is emitted through the base, in the indoor version through the roof. The airflow is protected by the kick plate and roof. It is also equipped with an additional fine air filter in this case. The indoor version has no filter in the exhaust air area; it is not included in the delivery. In this case, the base is also sealed with a plate.

The cleaning of the supply-air filter requires the roof to be removed.

The cleaning of the exhaust-air filter requires the kick plate to be removed.

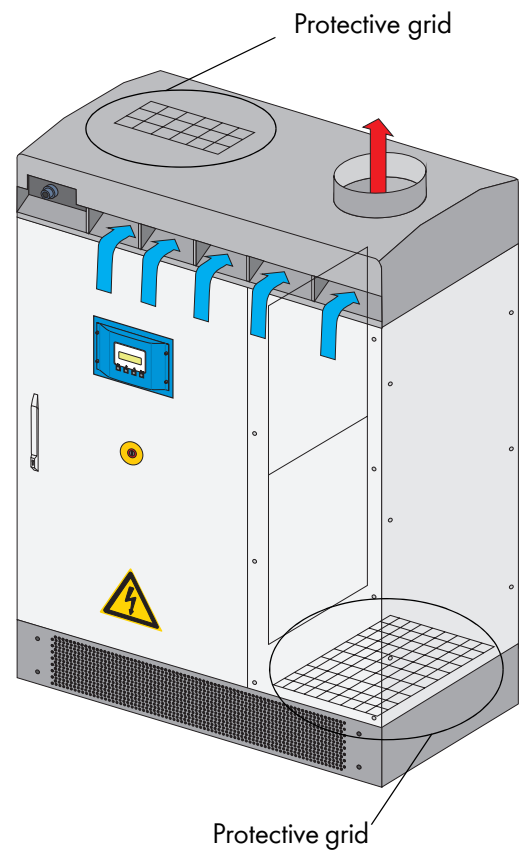

3.5.4 Removing the Roof

The Sunny Central 100indoor usually has an air duct through which the exhaust air is emitted to the outside. The air duct must be disassembled in order to remove the Sunny Central roof.

Depending on the product version, the Sunny Central 100 is produced with different roofs. The following describes how to disassemble the roof of both production versions.

Disassembling version 1

1. Loosen the screws at the left side in the roof of the Sunny Central.

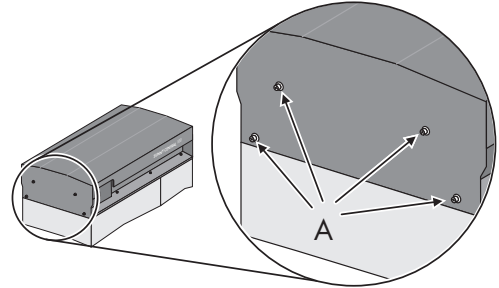

2. Loosen the screws at the right side in the roof of the Sunny Central.

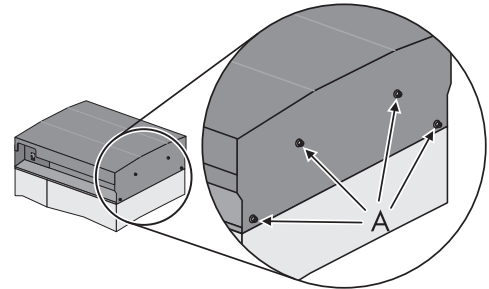

3. Lift the roof upward (1).
4. Remove the Start / Stop switch (2).

The roof is removed.

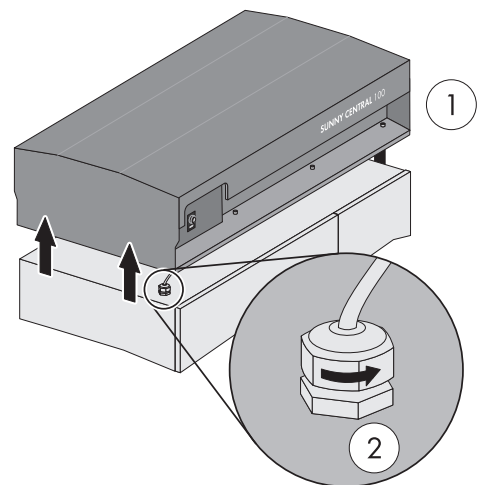

Disassembling version 2

1. Remove the Start / Stop switch.
2. Loosen the screws at the front filter in the roof of the Sunny Central.
3. Loosen the screws at the back filter of the Sunny Central.

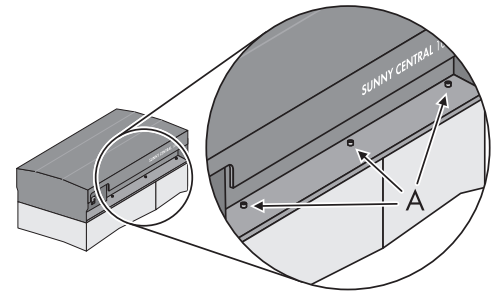

4. Pull the front filter forward and remove it.
5. Pull the rear filter forward and remove it.
Put the filter aside.

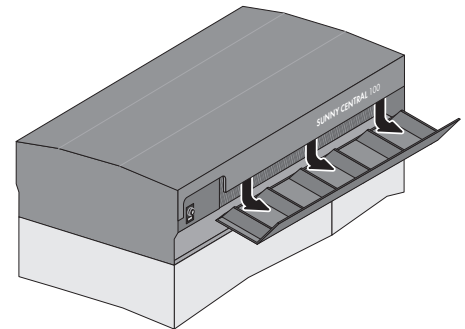

6. Remove the screws (A) which hold the roof at the Sunny Central.
The screws are in the place where the front filter was attached before.

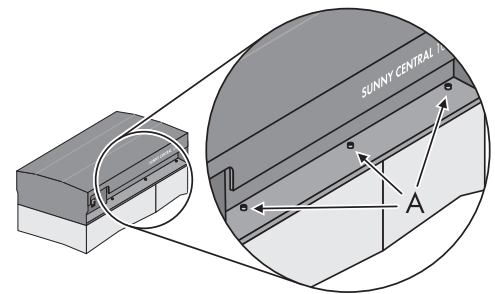

The roof can now be tilted backwards (1) to clean the filter in the roof of the switch cabinet.

7. If there is not enough space to tilt the roof backwards, remove it. To do so, loosen the cable gland (2) of the switch.
8. Unhook the roof and remove it by pulling it upwards.

The roof is removed.

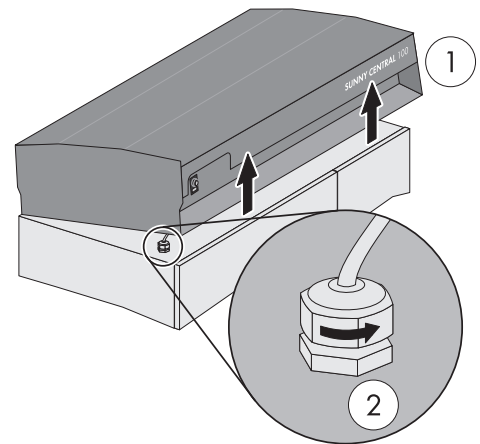

3.5.5 Removing the Kick Plates

The kick plate of the Sunny Central 100 is of a single-piece or two-piece design depending on the production variant. Identical kick plates are installed in both production versions.

1. Loosen the screws of the kick plate at the corners.
 2. Remove the kick plate by pulling it forward.
- The kick plate is removed.

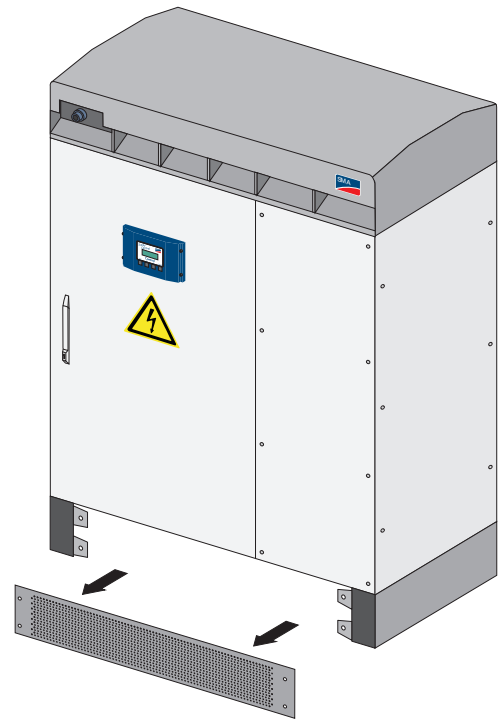

3.5.6 Removing the Exhaust Air Filter in the Base

1. Loosen the thumb nut at the filter in the base of the switch cabinet.
 2. Remove the filter.
- The filter can now be cleaned.

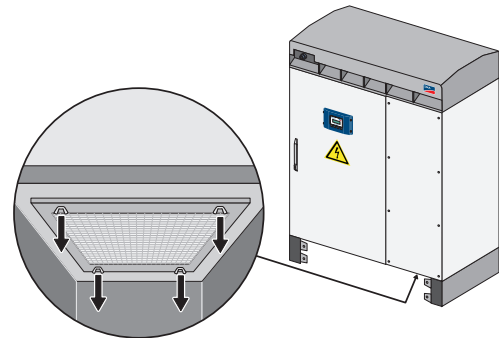

3.6 Sunny Central 100LV / SC 125LV / SC 150 / SC 200 / 200HE

The switch cabinets of type SC 100LV, SC 150, SC 125 LV and SC 200 are mostly identical in construction and equipped one protective grid (A) in the front. The exhaust air can either be discharged to the top or the back. The inverter is therefore equipped with a protective grid (A) in the roof or on the back side.

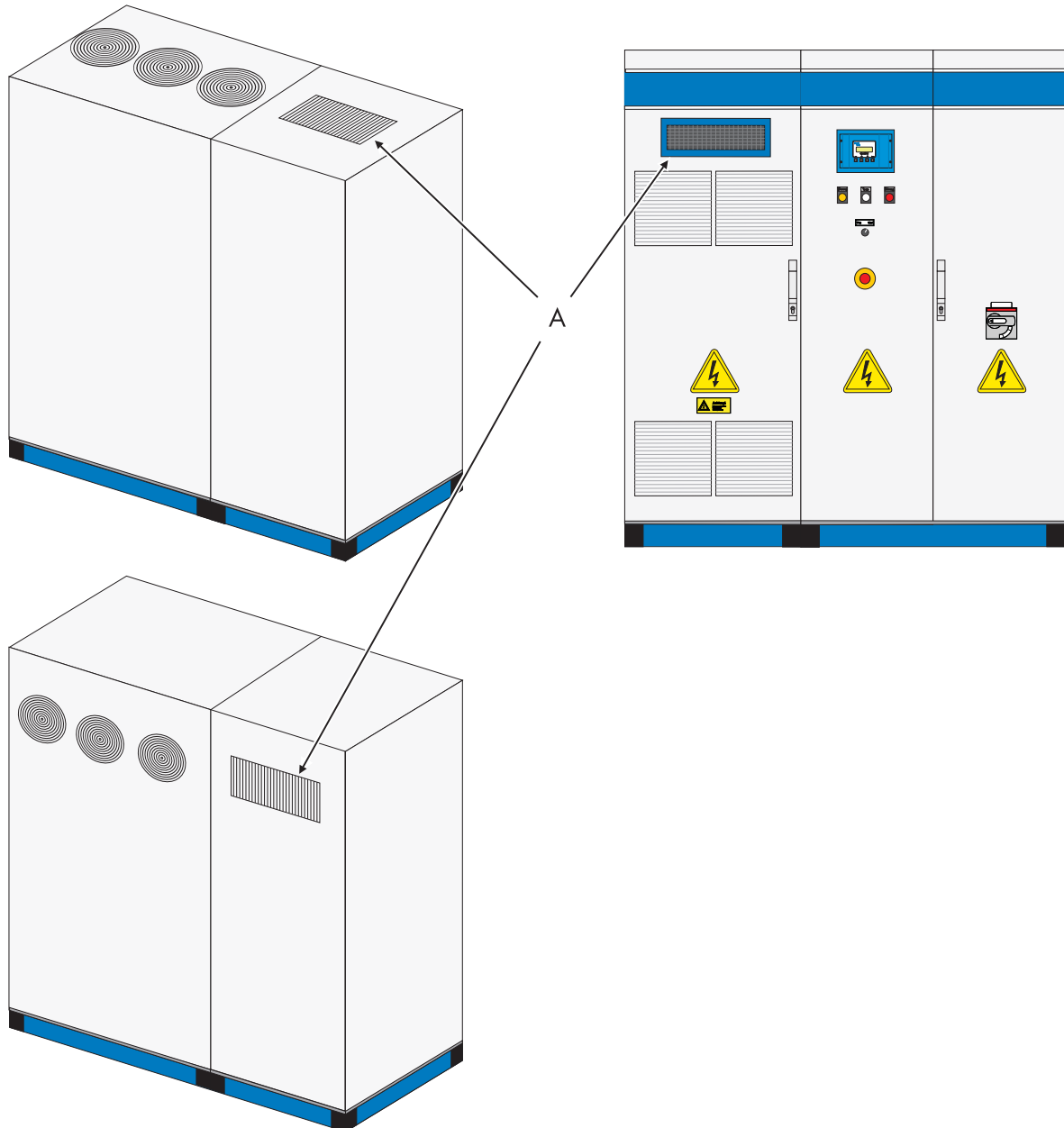

3.7 Sunny Central 250 / 250HE

The switch cabinet of the SC 250 / 250HE has two protective grids (A) in the front of the inverter cabinet. The exhaust air can either be discharged to the top or the back. Consequently, this device has either a grid (A) on the back side or in the roof.

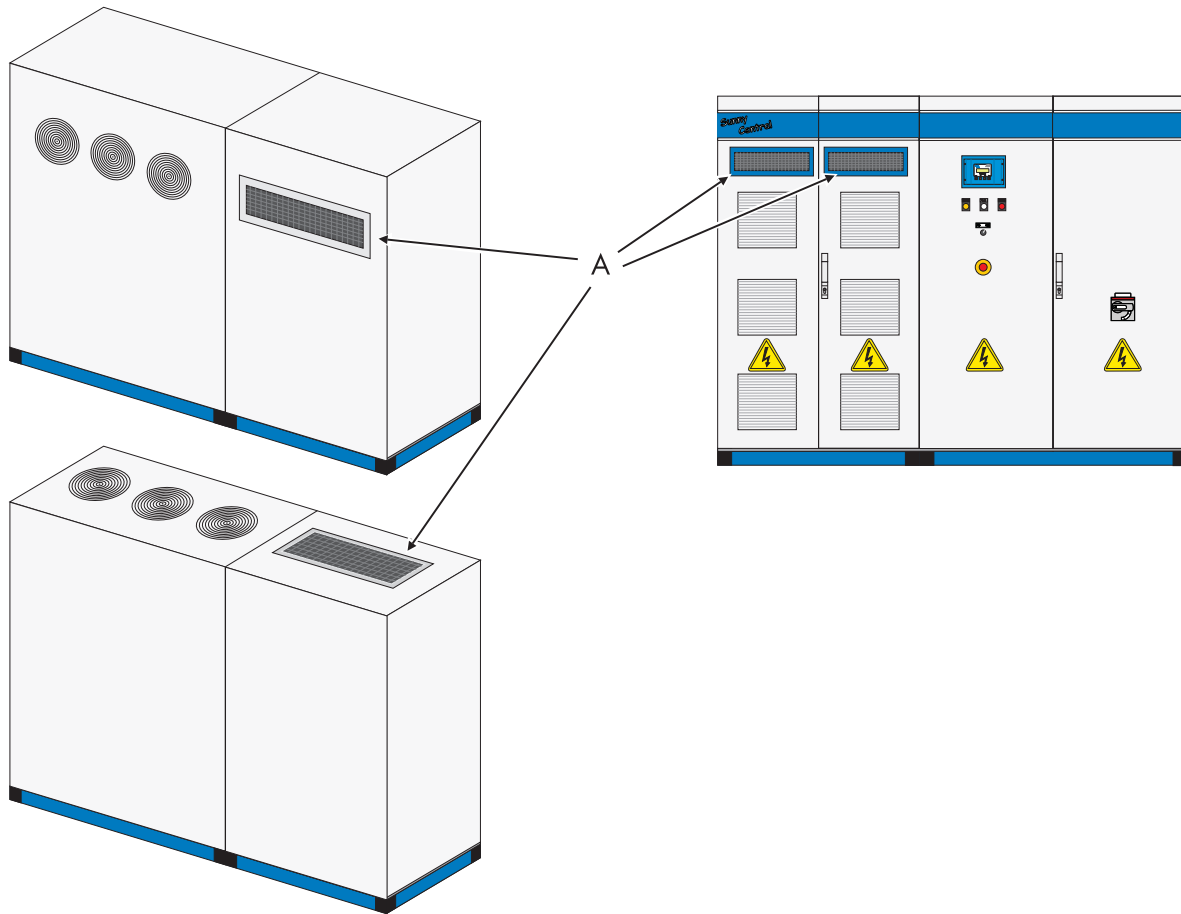

3.8 Sunny Central 350 / SC 350HE

The switch cabinet of the SC 350 has two protective grids (A) each in the front and on the back of the inverter cabinet.

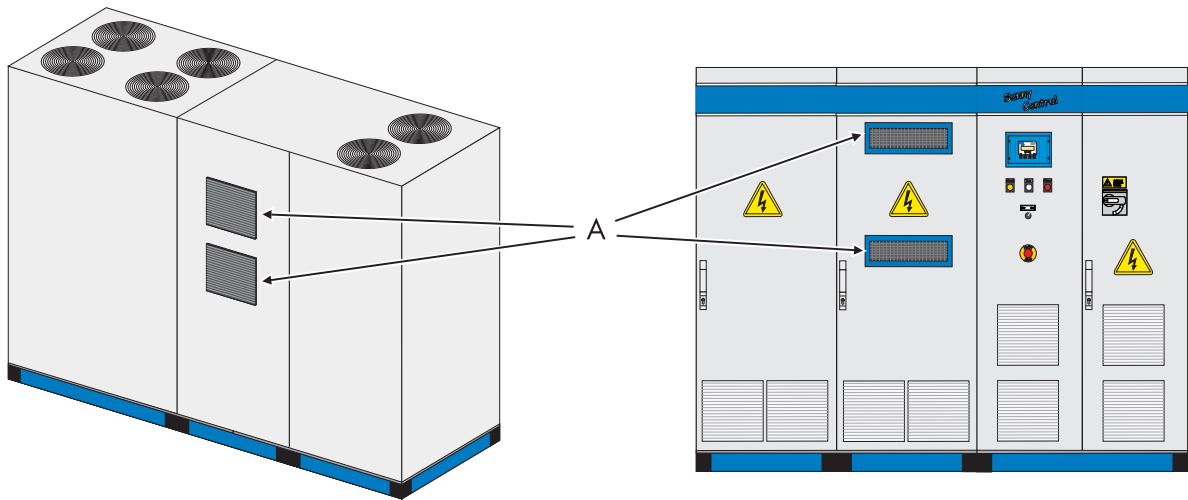

3.9 Sunny Central 500HE / 560HE / 400HE-11 / 500HE-11 / 630HE-11

Depending on the model, the switch cabinet of the SC 500HE has three protective grids (A) or one protective grid (A) of another type in the front of the inverter cabinet. The SC 500HE model with three protective grids in the front has also three protective grids at the rear panel. The switch cabinet of the SC 560HE is delivered with only one protective grid (A). The switch cabinets of the 11 series have the same protective grids as the Sunny Central 560HE.

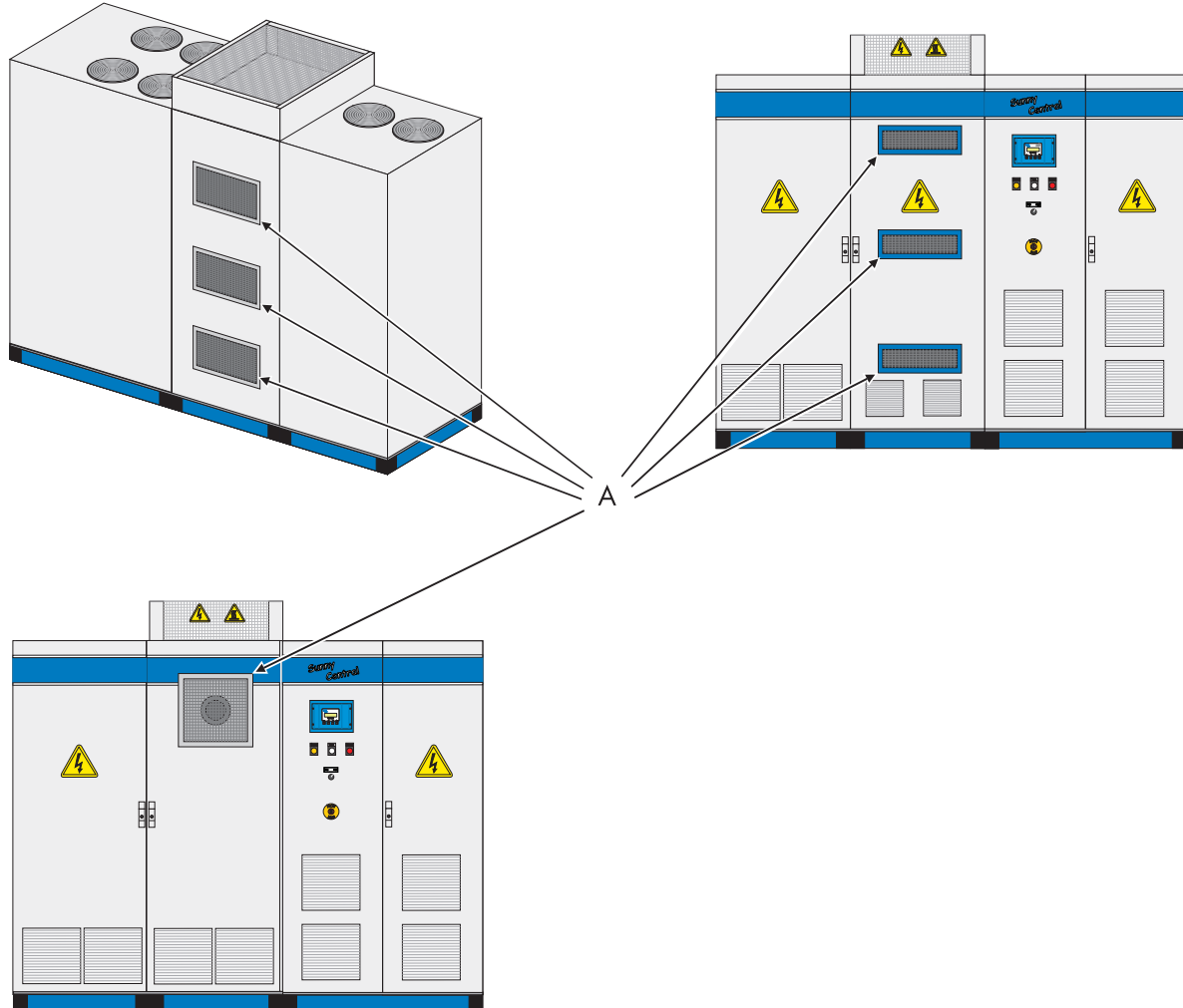

The devices mostly require no maintenance work. Due to the airflow of the power units positioned above one another, dirt of the bottom power unit may remain in the switch cabinet. Vacuum the chamber behind the bottom power unit for cleaning through the ventilation shaft.

Depending on the model, the switch cabinet of the SC 500HE has three protective grids (A) or one individual long ventilation shaft (B) on the back side. The switch cabinet of the Sunny Central 560HE and of the 11 series are only equipped with the individual ventilation shaft without grids.

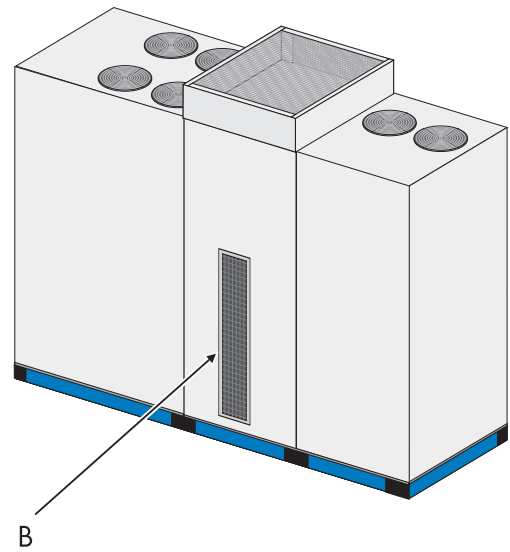
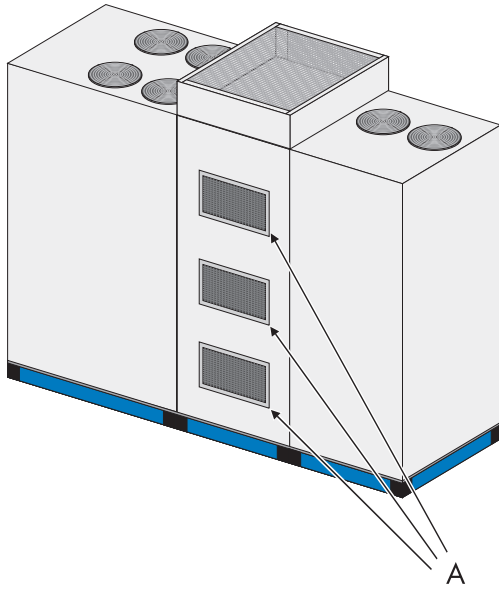

3.10 Sunny Central 400 / 500 / 700 / 1000 / 1120MV

The central inverters of this series consist each of two Sunny Central of the HE series with a common connection to a medium-voltage transformer.

How to clean the inverter inside the stations is described under the above mentioned points. The stations are equipped with several doors and windows (A) which serve as inverter ventilation. The doors and windows have protective grids and must also be cleaned.

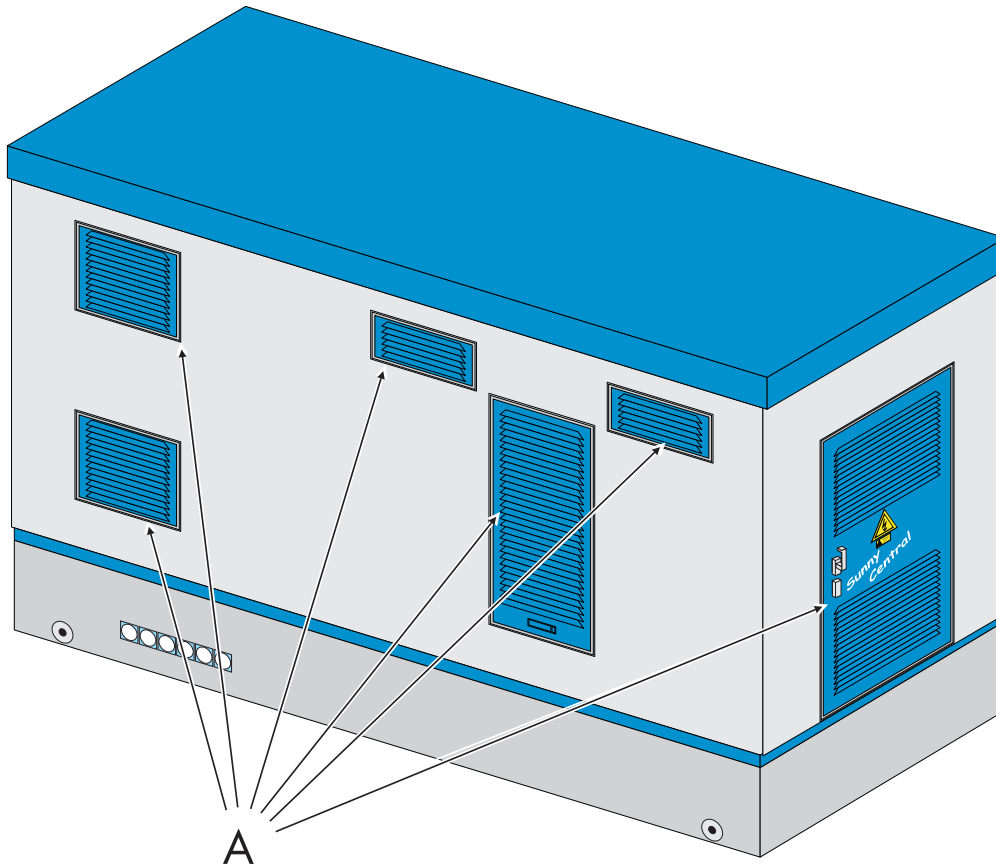

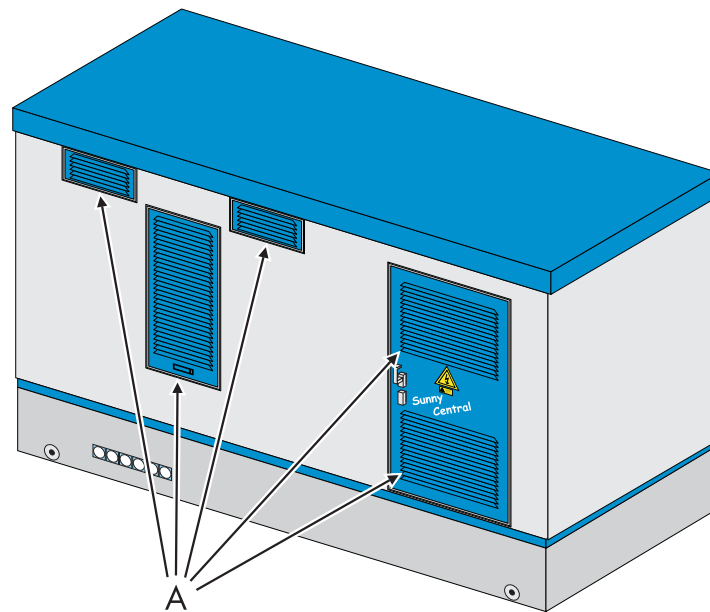

i **Size of doors and windows**

Depending on the size of the station, the form and size of the openings may vary. This depends on the inverters used in the station.

3.11 Checking the DC switching device at Sunny Central 400HE-11 /500HE-11 / 630HE-11

The Sunny Central of the HE-11 series are equipped with switching units from ABB Asea Brown Boverly Ltd.

In deviation to the maintenance interval specified by ABB, the maintenance interval of 24 months applies to the DC switchgear. For more information on maintenance activities of the DC switchgear, please visit www.abb.com:

| Component | Document Number |
|----------------------|-----------------|
| DC switchgear: T-Max | 1SDH000707R0001 |

3.12 Maintaining the Heat Exchanger

The Sunny Central with the ventilation option "chemically active" is equipped with a heat exchanger. Clean the fans and ventilation grids of the heat exchanger during maintenance.

Depending on the Sunny Central type, different heat exchangers are installed. As an example, the disassembling procedure is shown on a Sunny Central 250 and Sunny Central 630.

3.12.1 Disassembling the Heat Exchanger for Sunny Central 200 / 250

⚠ DANGER

- Only work on the device when it is switched off and voltage-free.

1. Open the doors of the DC/inverter cabinet.
The heat exchangers (A) are on the inside of the door of the switch cabinets.

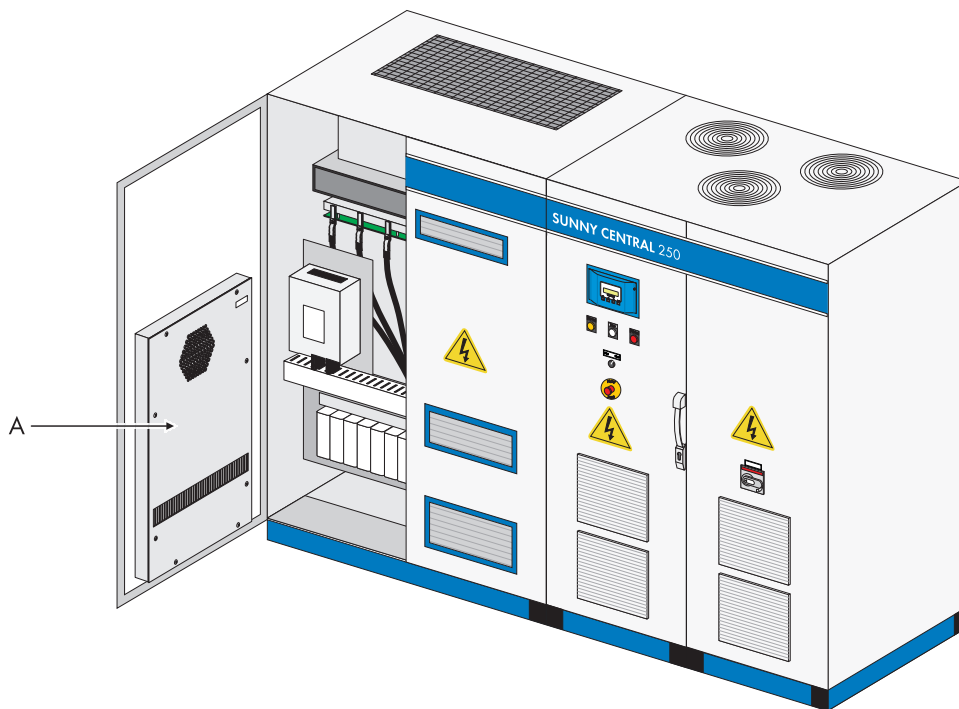

2. Remove the screws of the lid of the heat exchanger.
Place the screws aside.

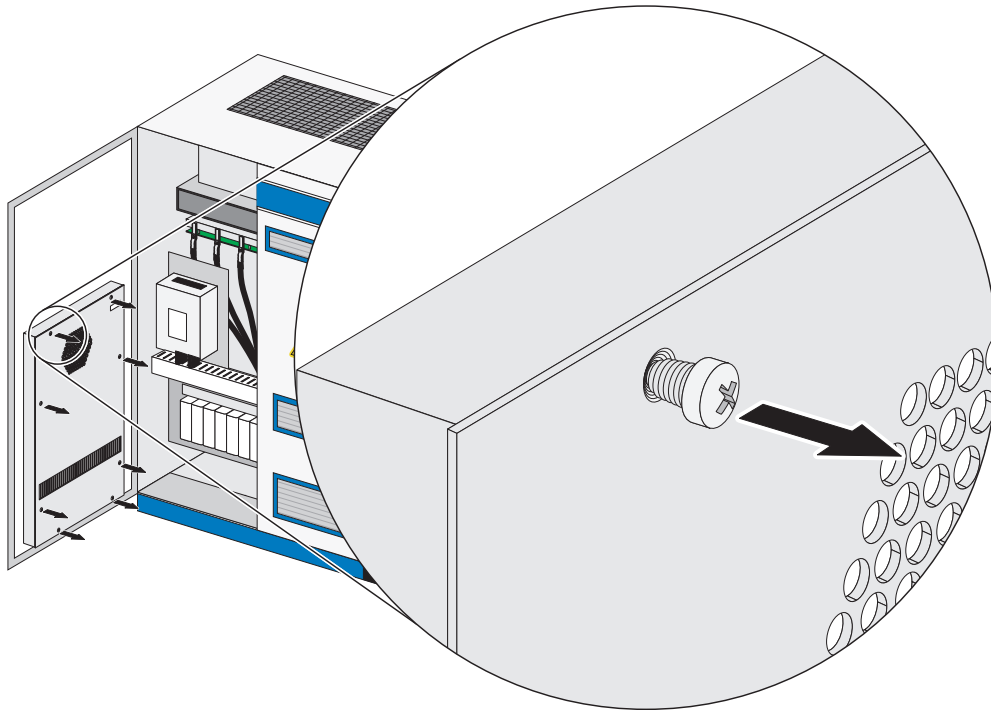

3. Pull the lid slightly forward.

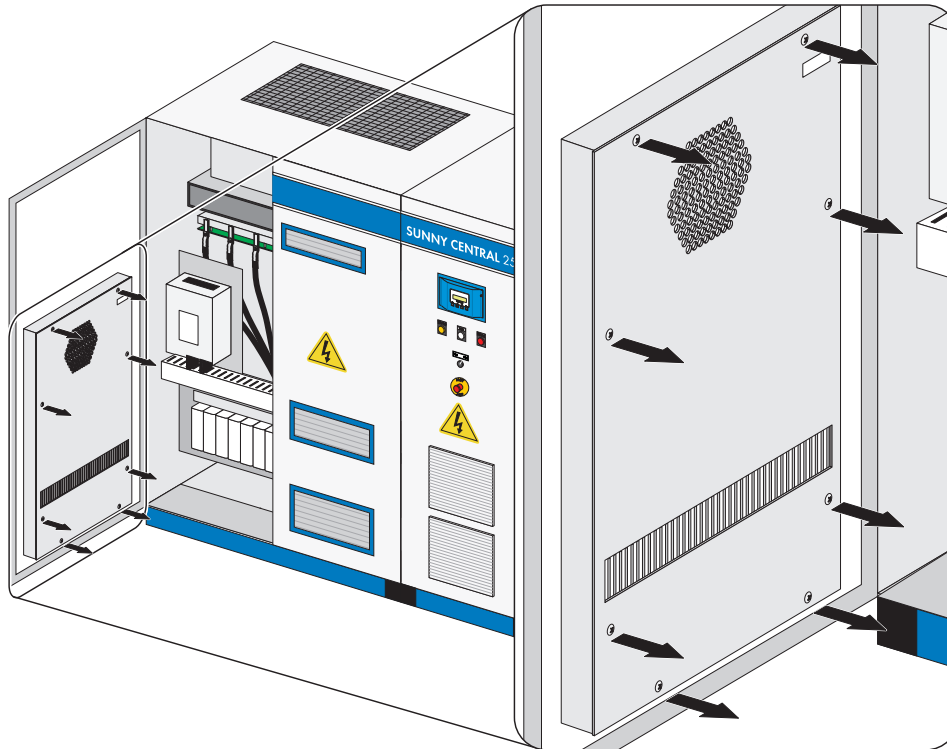

4. Remove grounding cable from the lid.

5. Place the lid aside.

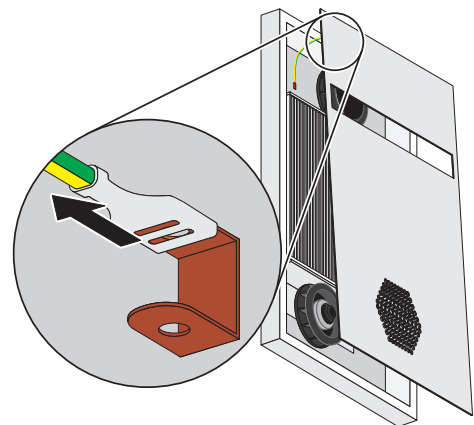

6. Disconnect the terminal of the power supply of the fans in the heat exchanger.

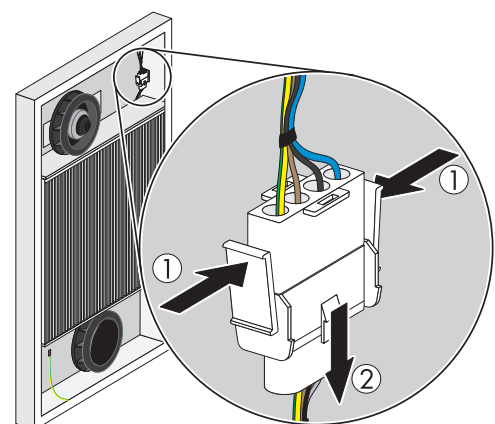

7. Unscrew and disassemble the top fan of the heat exchanger.
Place the fan aside.

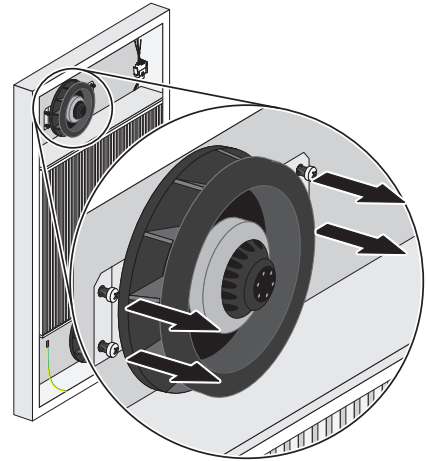

8. Unscrew and disassemble the bottom fan of the heat exchanger.
Place the fan aside.

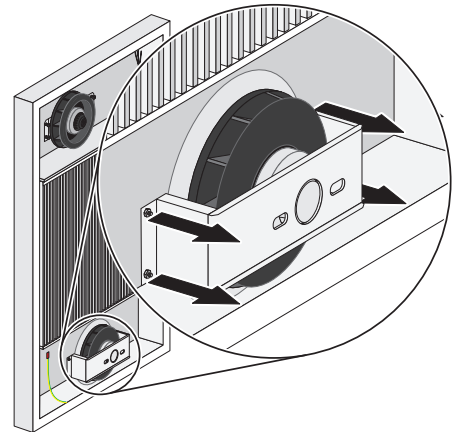

9. Clean the heat sink between the disassembled fans with a brush, a paint brush, a cloth or compressed air.
 10. Clean the ventilation grids as described in (see Section 3.4.1 "General Activities", page 10).
 11. Clean the fan with a soft brush, a paint brush, or a cloth.
- The heat exchanger has been cleaned.
Reassemble all parts of the heat exchanger.

3.12.2 Disassembling the Heat Exchanger of Sunny Central 400HE-11 / 500HE-11 / 630HE-11

⚠ DANGER

Danger to life due to electric shock or burns by touching live components

- Only work on the device when it is switched off and voltage-free.

1. Open the door of the DC cabinet.
The heat exchanger is on the inside of the door.
2. Remove the screws of the lid of the heat exchanger.
Place the screws aside.

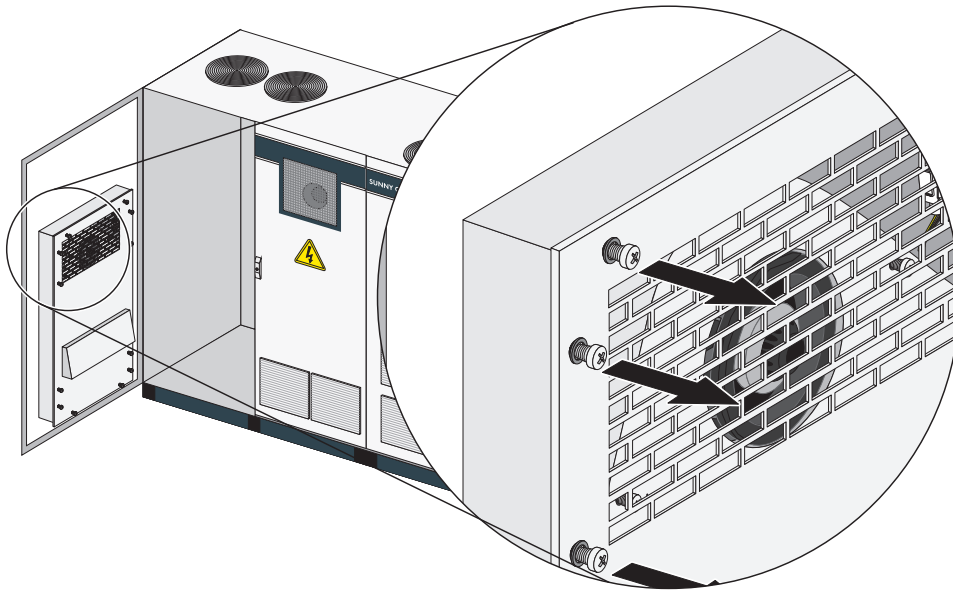

3. Pull the lid slightly forward.

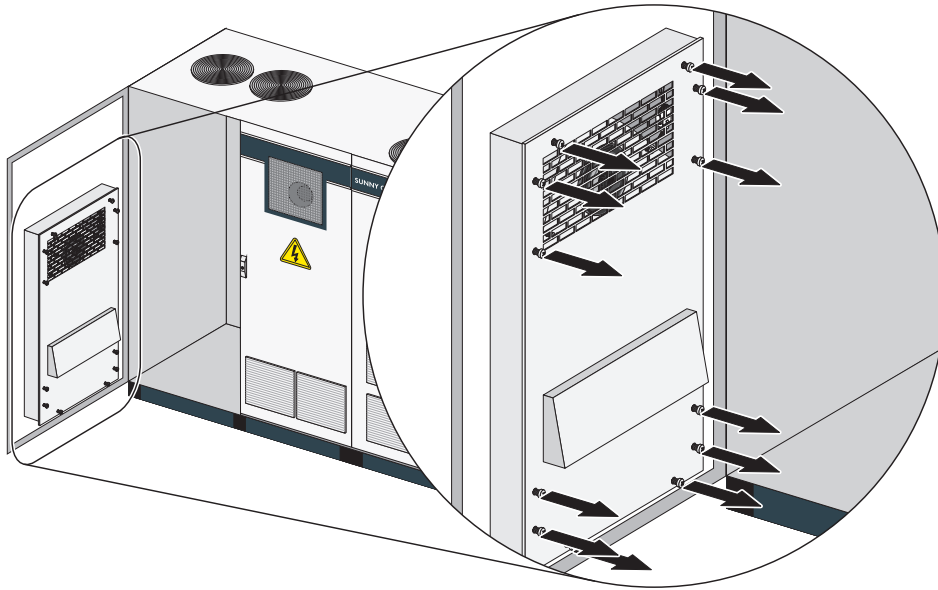

4. Remove grounding cable from the lid.
The grounding cable is located at the right bottom corner of the heat exchanger.
5. Place the lid aside.

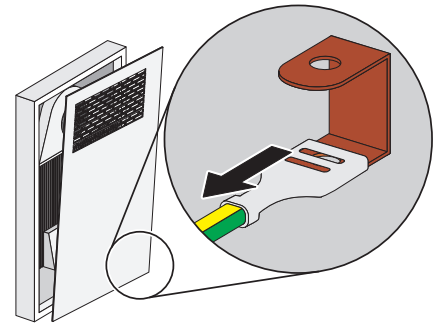

6. Disconnect the terminal of the power supply of the fans in the heat exchanger.

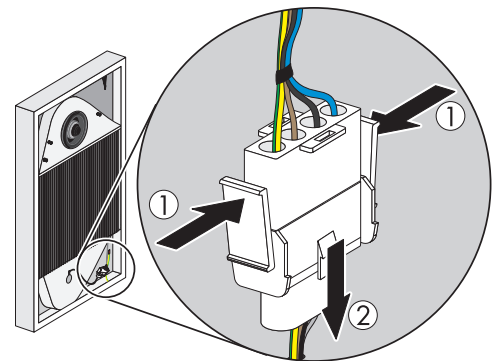

7. Unscrew and disassemble the cover of the top fan of the heat exchanger.

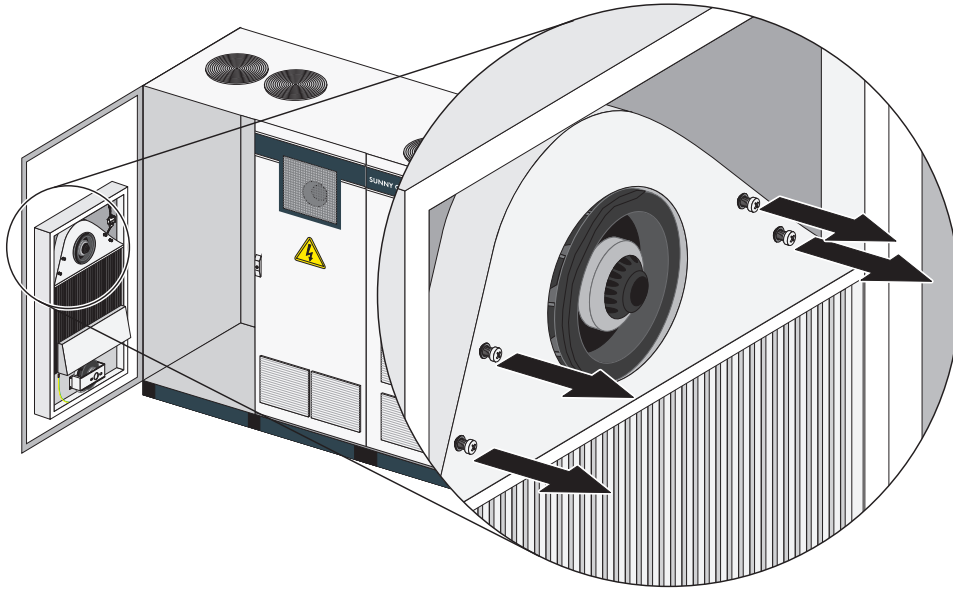

8. Unscrew and disassemble the cover of the bottom fan of the heat exchanger.

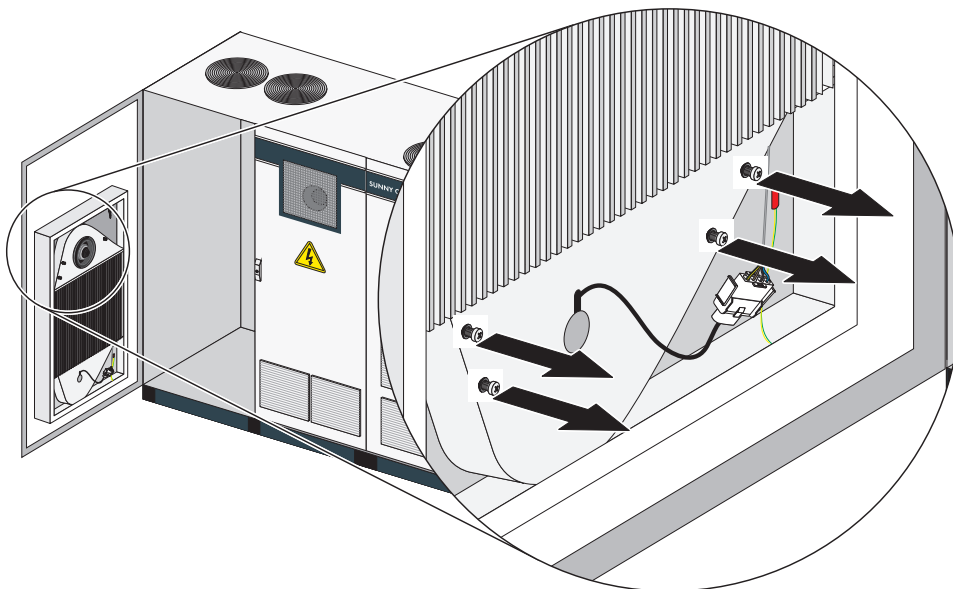

9. Clean ventilation grid between the disassembled fans with a brush, a paint brush, a cloth or compressed air.

10. Clean the fan with a soft brush, a paint brush, or a cloth.

The heat exchanger has been cleaned.

Reassemble all parts of the heat exchanger.

4 Covers and Lockings

4.1 Checking the Function of the Internal and External Emergency Switch.

The exact position of the respective switch can be determined with the aid of the reference designation and provided circuit diagram.

⚠ DANGER

Danger to life due to electric shock or burns by touching live components

- Do not touch parts other than those described in the instructions.

1. Switch the Sunny Central to "Stop" and open the doors.
2. Ensure that the Sunny Central is connected to a control voltage (supply voltage) and supplied with power.
3. Make sure that the emergency stop on the outside of the device is not activated.
4. Tape all door contact switches to the "On" position.
 - ☑ During normal operation, both signal lights (A) of the emergency switch relay must be illuminated.

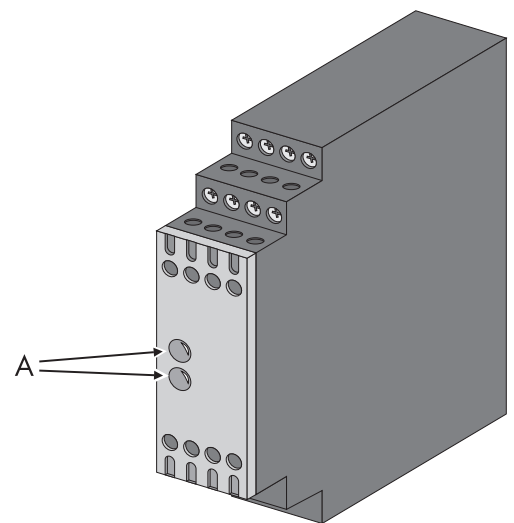

5. If the emergency switch is activated, the indicator lights at the emergency stop relay "OFF" have to switch.
 - ☑ The Sunny Central Control displays error message "206" and the fault must be acknowledged manually.
6. Unlock emergency switch and confirm the error at Sunny Central Control.
7. Release door contact switches (remove the adhesive tape)
8. Close the cabinet doors.

i Testing the emergency switch circuits

In a Team configuration or in plants with several Sunny Central inverters connected in a Team configuration, the emergency stop relay must switch in all cabinets.

i Connecting the emergency stop relay

Depending on the switch cabinet design and production version, the emergency switch relay is installed with the indicator lights at the control unit.

9. Carry out a functional test on each emergency switch. Test the switches on the cabinet, in the stations, and the other external emergency stop switches.

4.2 Checking the Door Contact Switch

Depending on the switch cabinet model and production version, the following door contact switches of the companies Rittal and IBB are installed.

View of the door contact switches

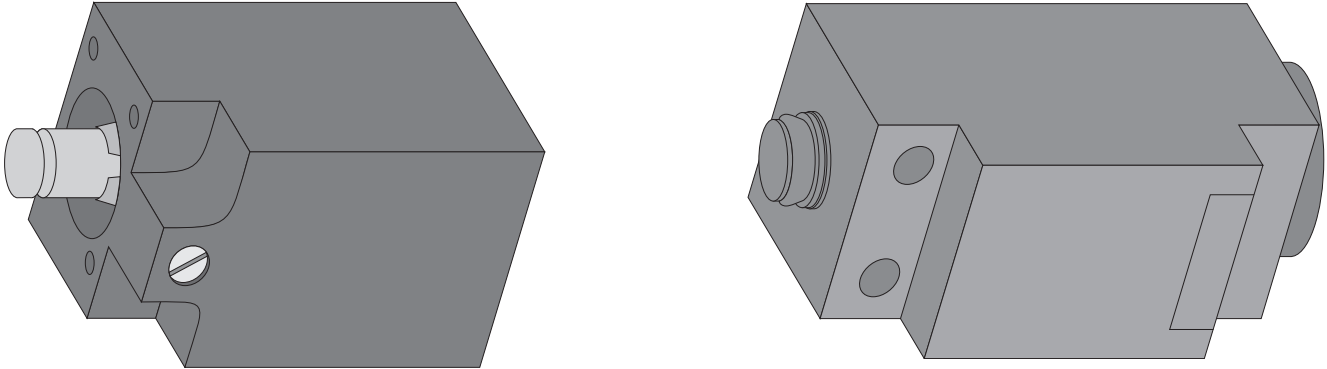

⚠ DANGER

Danger to life due to electric shock or burns by touching live components

- Do not touch parts other than those described in the instructions.

1. Switch the Sunny Central to "Stop" and open the doors.
2. Ensure that the Sunny Central is connected to a control voltage (supply voltage) and supplied with power.
3. Make sure that the emergency stop on the outside of the device is not activated.
4. Tape all door contact switches to the "On" position.
 - During normal operation, both signal lights (A) of the emergency switch relay must be illuminated.

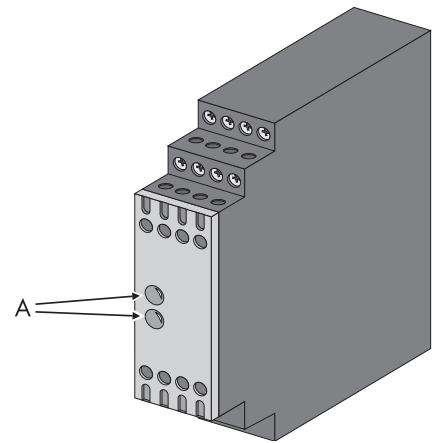

5. Switch off and then switch on again one after another all door contact switches by loosening the tape fixing.
 - Signal lights at the emergency stop relay turn off as long as it is switched off.
 - In "Stop" mode, there is no signal at the Sunny Central Control.
6. Release door contact switches (remove the adhesive tape)
7. Close the cabinet doors.

New door contact switches can be ordered from SMA if they need to be replaced.

4.3 Checking the seals

⚠ DANGER**Danger to life due to electric shock or burns by touching live components**

- Only work on the device when it is switched off and voltage-free.

Seals are at the doors of the switch cabinets as well as at the Sunny Centrals which consist of two switch cabinet units at the connecting point between the two units.

1. Visually check the switch cabinet's seals for cracks or other damages.
 - Seals in the sealing area must be completely replaced when damaged.
 - In case the seals are damaged outside this area, a sufficient sealing effect is usually still available.
2. In order to prevent damage due to freezing of the seals caused by the weather, use talcum, vaseline or wax.

4.4 Checking the locking devices and hinges

⚠ DANGER**Danger to life due to electric shock or burns by touching live components**

- Only work on the device when it is switched off and voltage-free.

1. Check for the correct operation of the locks of the inverter cabinets and concrete stations by opening and closing the doors.
 - A locking which cannot be moved smoothly indicates corrosion and thus leakage.
2. Check which part of the locking is damaged and take corrective measures.
3. Make sure that the door's hinges move easily.
4. Check the function of the door stay. Replace defective door stays.
5. Spray all moveable locking elements and movement points with a suitable lubricant which is free of water.

5 Maintaining the Inside of the Switch Cabinet

5.1 Checking the Inside of the Switch Cabinet for Contamination

⚠ DANGER**Danger to life due to electric shock or burns by touching live components**

- Only work on the device when it is switched off and voltage-free.

1. Check the inside of the switch cabinet for heavy dust deposits, dirt, moisture and water penetration from outside.
2. If necessary, clean the Sunny Central and take suitable corrective measures.

5.2 Cleaning the Power Unit of the Heat Sink

⚠ DANGER

Danger to life due to electric shock or burns by touching live components

- Only work on the device when it is switched off and voltage-free.

i Maintenance requirements of power unit of the heat sink

The power unit of the heat sink requires almost no maintenance work, an optical check is sufficient.

As a rule, cleaning the power unit of the heat sink is only required in case of an inverter failure. The dirt is usually absorbed by the protective grids. These grids are designed in such way that the hole diameter is as large as the openings of the heat sink.

The figure below shows the heat sink (A) of a Sunny Central 250

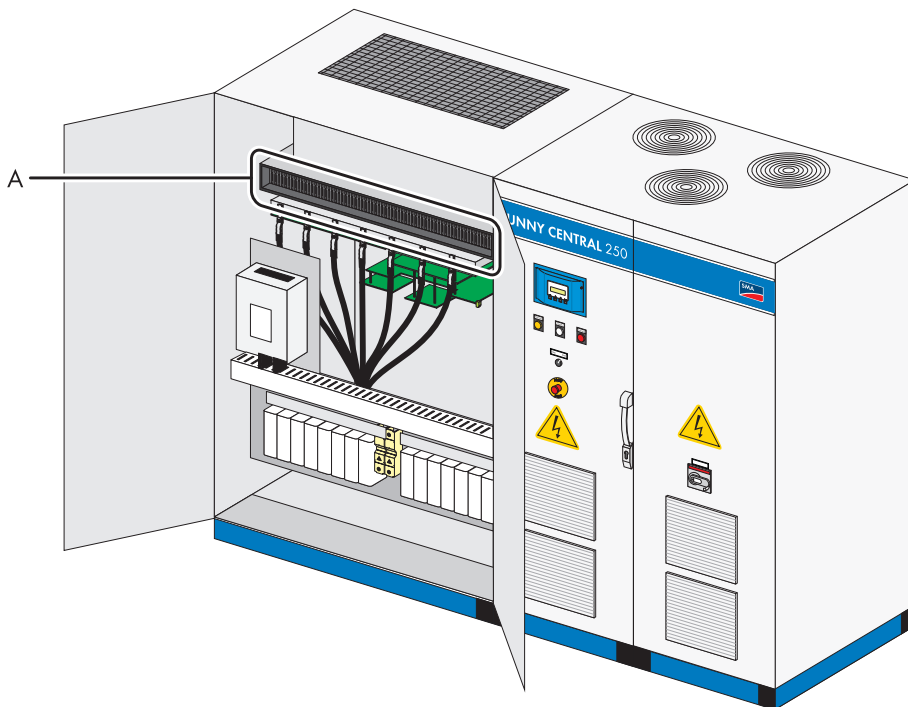

If the heat sink is dirty, it can be cleaned with compressed air. Cleaning with a vacuum cleaner is not permissible as this procedure would only allow the cleaning of a small part of the heat sink.

5.3 Cleaning the EVR Resistor

⚠ DANGER

Danger to life due to electric shock or burns by touching live components

- Only work on the device when it is switched off and voltage-free.

i Maintenance work on the EVR

The EVR requires almost no maintenance work. An optical check is sufficient.

The EVR resistor is an optional accessory located on the roof of the Sunny Central, or is installed inside the Sunny Central.

1. Check the EVR resistor for heavy dust deposits, dirt, and moisture.
2. If necessary, clean the EVR resistor and take suitable measures to protect it against new dirt.

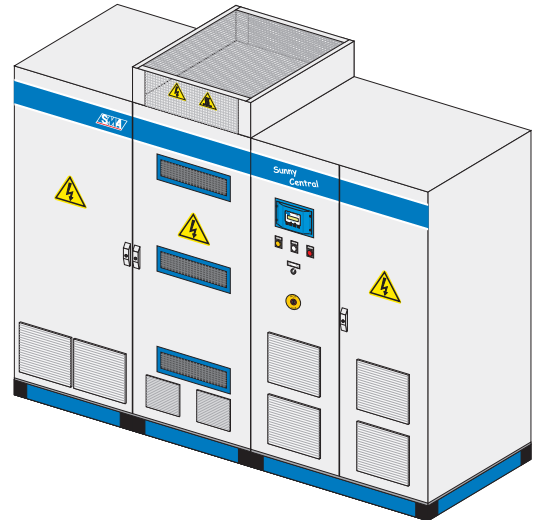

5.4 Checking the Power Cable Connections

⚠ DANGER

Danger to life due to electric shock or burns by touching live components

- Only work on the device when it is switched off and voltage-free.

NOTICE

Damage to the clamp connections due to over-tightening.

- Only tighten the aluminum clamp connections if they are loose.

1. Check all power cable connections for looseness and tighten them if necessary.

i Torque specifications

You will find the torques of the individual connections in the Sunny Central circuit diagram. If no torque specifications are available, contact the Sunny Central Service.

2. Check the connectors and insulation for discoloration or degradation.
3. If necessary, replace any damaged connectors or corroded contacts.

5.5 Checking the Warning Messages

⚠ DANGER

Danger to life due to electric shock or burns by touching live components

- Only work on the device when it is switched off and voltage-free.

Check the safety notices and stickers on and in the switch cabinet and replace missing or damaged labels.

5.6 Checking the Fans and Thermostats

⚠ DANGER**Danger to life due to electric shock or burns by touching live components**

- Only work on the device when it is switched off and voltage-free.

Depending on the switch cabinet model, the following fans are available:

- Cabinet cooling fan
- Heat sink fan(s)
- Interior rotating fan(s)
- Heating fan
- Diode fan
- Heat exchanger fans

Check all cooling fans for functionality and operating noise. The fans can be switched on by adjusting the thermostats.

1. Switch the Sunny Central to "Stop" and open the doors.
2. Ensure that the Sunny Central is connected to a control voltage (supply voltage) and supplied with power.
3. Tape all door contact switches to the "On" position.
4. Slowly turn down each thermostat until the fans start to run. Note down the temperature reached of each thermostat.
5. Replace fans if they do not start to run or emit unusual noise during operation.
6. Slowly turn up each thermostat until the fans shut down again. Note down the temperature reached of each thermostat.
7. Replace thermostats when the temperature difference is higher than 5 K.
8. Once the functional test of all fans has been conducted, adjust the thermostats back to the initial setting. The value is specified with an adhesive label on the thumb wheel and in the circuit diagram.
9. Release door contact switches (remove the adhesive tape)
10. Close the cabinet doors.

5.7 Checking the heating element and the hygostat

Depending on the switch cabinet model and production version, one or several heating models of the Rittal, Stego or Heine company are installed.

You can locate the exact position, number of heaters, and the corresponding hygostats using the reference designation of the components in the provided circuit diagram.

Views of the heaters and hygostat

Rittal heating (300 W)

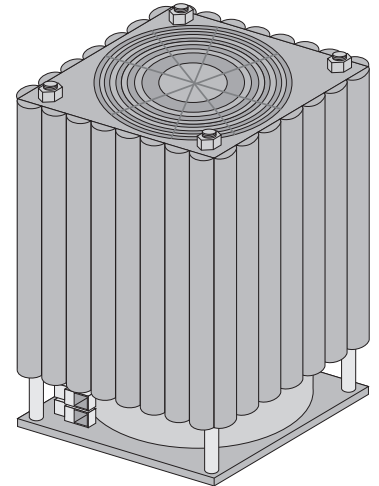

Stego heating (300 / 400 W)

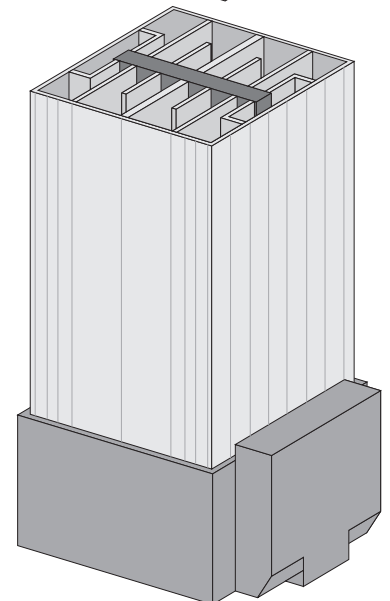

i Different types of construction

Heaters of the similar construction type of the company Heine are also installed in a few switch cabinets.

Hygostat view

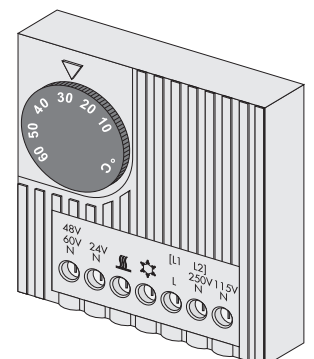

Procedure for checking the heating

DANGER

Danger to life due to electric shock or burns by touching live components

- Only work on the device when it is switched off and voltage-free.

1. Switch the Sunny Central to "Stop" and open the doors.
2. Ensure that the Sunny Central is connected to a control voltage (supply voltage).
3. Tape door contact switch to the "On" position.
4. Turn the hygrostat down as far down as possible.
 - If the value is smaller than the current air humidity, the heater is activated.

i Air humidity is too low

If the air humidity is too low, a functional test of the heater can not be carried out. In this case, the hygrostat does not switch on, even if it is set to the minimum value.

CAUTION

Risk of burns due to hot heating elements

- Do not touch parts other than those described in the instructions.

- If the hygrostat has been connected through, the heating fans must start and the air blown through the heat sink must heat up.
5. Once the functional test of the heating has been conducted, adjust the hygrostat back to the initial setting. The value is specified with an adhesive label on the thumb wheel and in the circuit diagram.
 6. Release door contact switches (remove the adhesive tape)
 7. Close the cabinet doors.

5.8 Replacing the Battery of the Sunny Central Control

The battery in the Sunny Central Control must be replaced at least every eight years.

DANGER

Danger to life due to electric shock or burns by touching live components

- Only work on the device when it is switched off and voltage-free.

1. Save the instantaneous values of the parameters **E-Total**, **h-on**, **h-Total** and **DCScahlf.-Cnt**.
2. Switch the Sunny Central to "Stop" and open the doors.
3. Loosen the four fastening screws of the Sunny Central Control and remove it.

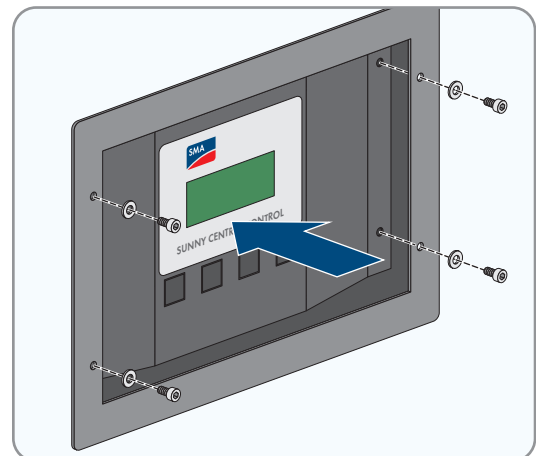

4. Take off the lid of the Sunny Central Control.

5. **NOTICE**

Damage to the inverter due to electrostatic discharge

Touching electronic components can cause damage to or destroy the inverter through electrostatic discharge.

- Ground yourself before touching any component.

6. Replace the battery.

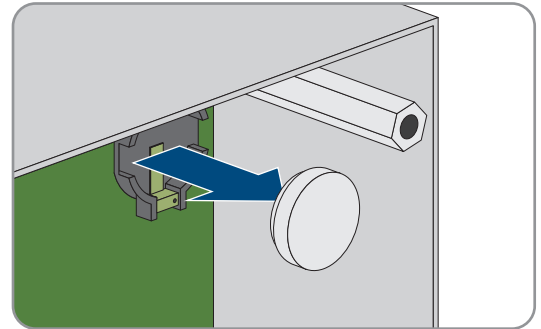

7. Reattach the lid of the Sunny Central Control.

8. Reattach the Sunny Central Control to the door of the inverter and tighten the four fastening screws.

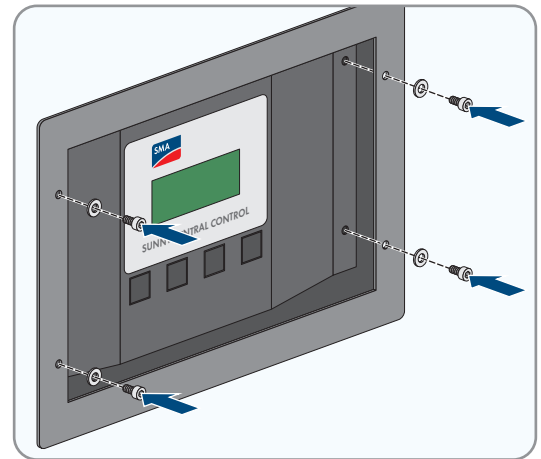

9. Restart the Sunny Central.

10. Restore the saved instantaneous values of the parameters **E-Total**, **h-on**, **h-Total** and **DCSchlft.-Cnt.**

6 Checking the Protective Devices

6.1 General Information on Protective Devices

Depending on the switch cabinet model and production version, the central inverters have several circuit breakers which need to be regularly checked for correct function.

You can locate the exact position and the number of circuit breakers using the reference designation of the components in the provided circuit diagram.

Depending on the switch cabinet model, the following circuit breakers are available:

- Residual-current device
- Miniature circuit breaker
- Line circuit breaker
- Motor-protective circuit-breaker

6.2 Checking the Residual Current Device in the SC 100

The control voltage (supply voltage) is fed to the outside in some Sunny Central inverters in order to feed external devices, such as COM-B. To protect these devices, these Sunny Central inverters have residual current breaker. The residual current breaker has a function test button. When pressing this button, the failure can be simulated.

⚠ DANGER

Danger to life due to electric shock or burns by touching live components

- Only work on the device when it is switched off and voltage-free.

1. Switch the Sunny Central to "Stop" and open the doors.
 2. Ensure that the Sunny Central is connected to a control voltage (supply voltage) and supplied with power.
 3. Tape door contact switch to the "On" position.
 4. Check the residual current breaker by pressing the function test button (A).
- The switch trips.
- The service socket is switched off. Negative-glow lamp at power outlet switches off.

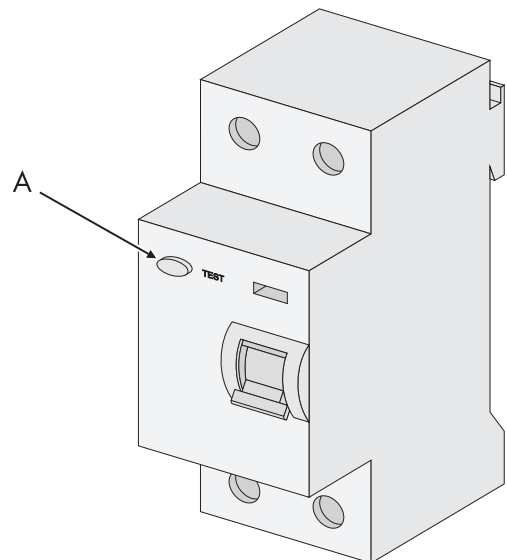

5. Reconnect the residual current breaker.
6. Release door contact switches (remove the adhesive tape)
7. Close the cabinet doors.

6.3 Checking the Circuit Breaker

The circuit breaker is connected with the door via an extension spindle. The door itself has no contacts since it cannot be opened when the switch is activated.

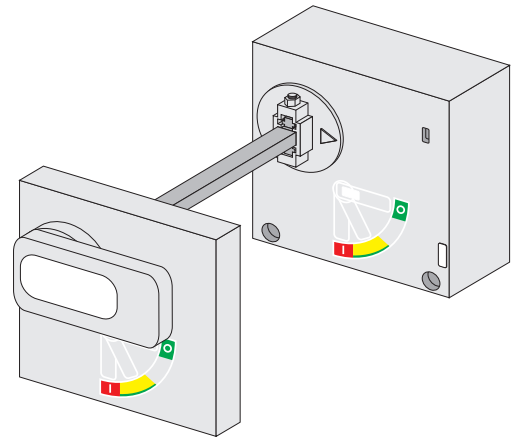

⚠ DANGER

Danger to life due to electric shock or burns by touching live components

- Only work on the device when it is switched off and voltage-free.

1. To open the door of the Sunny Central when the cabinet is switched on, remove the handle from the extension spindle that connects the switch to the handle. The door can then be opened.
2. Switch the Sunny Central to "Stop" and open the doors.
3. Ensure that the Sunny Central is connected to a control voltage (supply voltage) and supplied with power.
4. Tape door contact switch to the "On" position.
5. Switch the Sunny Central to "Start."
6. Check the residual current breaker by pressing the function test button (A).
 - The switch trips.

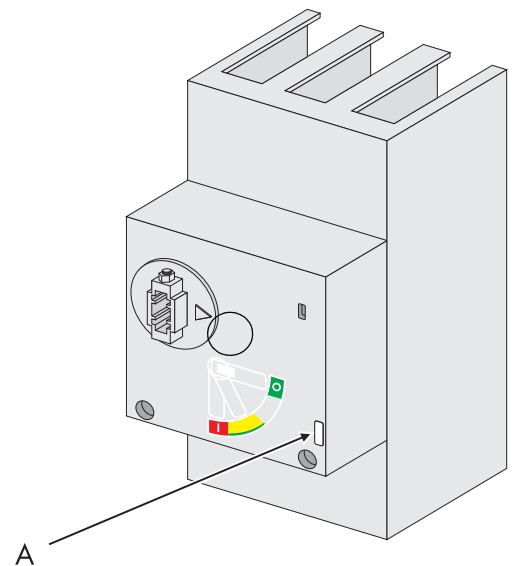

7. Switch the Sunny Central to "Stop."
8. Release door contact switches (remove the adhesive tape)
9. Close the cabinet doors.

6.4 Checking the DC Main Switch

Depending on the model and power class, different motor-driven circuit breakers in the Sunny Central inverters are used on the DC side.

6.4.1 Circuit Breaker and Load-Break Switch

Motor-driven DC circuit breaker (spring power storage device)

This switch is equipped with a circuit breaker (A), a spring power storage device (B), an off key, (C) and a position display (D). It is used in the following Sunny Central devices:

- Sunny Central 100LV
- Sunny Central 125LV
- Sunny Central 150
- Sunny Central 200 / 200HE
- Sunny Central 250 / 250HE
- Sunny Central 350 / 350HE
- Sunny Central 500HE
- Sunny Central 560HE

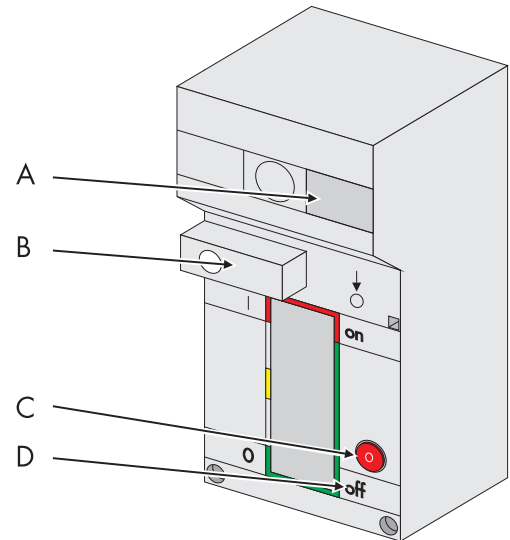

This switch is equipped with a circuit breaker (A), a spring power storage device (B), an off key, (C) and a position display (D). It is used in the following Sunny Central devices:

- Sunny Central 400HE-11
- Sunny Central 500HE-11
- Sunny Central 630HE-11

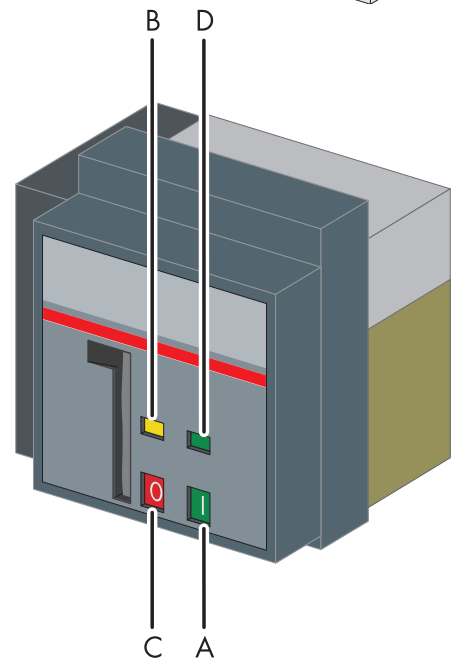

Motor-driven DC circuit breaker (direct drive)

This switch has a switch-on device (A), a position display (B), an off-key (C) and a slider (D) for setting the automatic / manual operation. It is used in the following Sunny Central devices:

- SC100indoor
- SC100outdoor

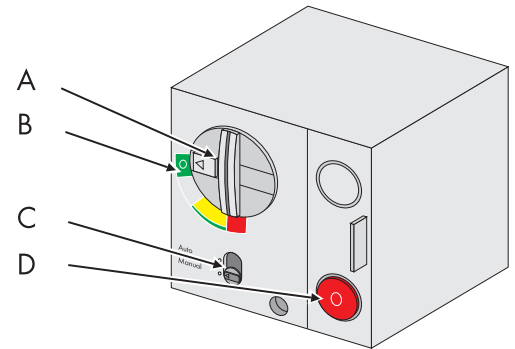

Procedure for checking the DC circuit breaker

1. Switch the Sunny Central to "Stop" and open the doors.
2. Ensure that the Sunny Central is connected to a control voltage (supply voltage) and supplied with power.
3. Tape door contact switch to the "On" position.
4. Switch the Sunny Central to "Start."
 - ☑ The DC switch is switched on and shifts to "On" position.
5. Switch the Sunny Central to "Stop."
 - ☑ The DC switch trips and shifts to "Off" position.
6. Release door contact switches (remove the adhesive tape)
7. Close the cabinet doors.

6.5 Checking the Fuses and Disconnectors

⚠ DANGER**Danger to life due to electric shock or burns by touching live components**

- Only work on the device when it is switched off and voltage-free.
1. Visually check the existing fuses and tension springs on the fuse holders.
 2. Check all power cable connections for looseness and tighten them if necessary. Check the connectors and insulation for discoloration or degradation. Replace any damaged connectors or corroded contacts.
 3. Check all string cable connections for looseness and tighten them if necessary. Check the insulation, and the terminals on the assembly as well on the busbar for discoloration or degradation.
 4. Check whether the fuses can be easily pulled out of the fuse holders. If a fuse is difficult to remove from the fuse holder, clean and lubricate it.
 5. Check whether the blade contacts of the fuses are from hardened grease. If there is hardened grease on the blade contacts of a fuse, clean and lubricate it.
 6. If necessary, lubricate the contacts.
- The check of the fuses and disconnectors is completed.

6.6 Checking the surge arresters

6.6.1 Information for Checking the Surge Arrester

⚠ DANGER**Danger to life due to electric shock or burns by touching live components**

- Only work on the device when it is switched off and voltage-free.

Depending on the switch cabinet model and production version, the central inverters have several overvoltage protectors which need to be regularly checked for correct function.

You can locate the exact position and number of overvoltage protectors using the reference designation of the components in the provided circuit diagram.

The overvoltage protectors are inspected visually and by means of measurements.

6.6.2 Checking the Dehn Guard

1. Visual inspection of arrester for signs of wear.
2. Check the operating readiness of the arrester via the function and fault signaling (A) of the protection path which is free of operating current.

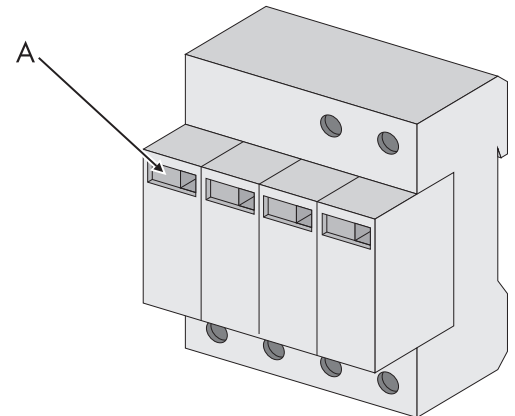

Visual display green

Overvoltage protector is ready for operation.

Visual display red

Overvoltage protector defective

Measurements

An exact statement about the state of the arrester can only be made with an appropriate test device. The PM20 from Dehn + Söhne GmbH & Co. KG is the suitable test device for this purpose. The measurement procedure is described in the user manual of the device and has to be carried out by an electrically skilled person.

6.6.3 Checking the Blitzductor

1. Visual inspection of arrester for signs of wear.
2. A visual inspection is not possible for this arrester. Determine whether the inverter is ready for operation by means of a measuring device.

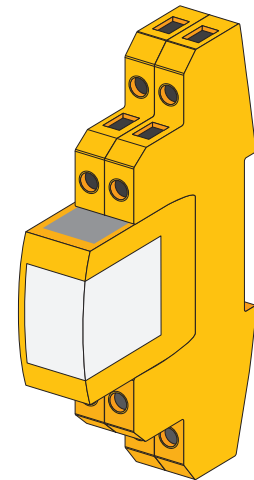

Measurements

An exact statement about the state of the arrester can only be made with an appropriate test device. The DEHNrecorder LC M3 from Dehn + Söhne GmbH & Co. KG is the suitable test device for this purpose. The measurement procedure is described in the user manual of the device and has to be carried out by an electrically skilled person.

6.7 Maintaining the GFDI

⚠ DANGER**Danger to life due to electric shock or burns by touching live components**

- Only work on the device when it is switched off and voltage-free.

The GFDI is subject to aging caused by wear of the contacts every time they are tripped. Due to aging, sensitivity is reduced. To ensure the GFDI function, check the insulation of the PV array at regular maintenance intervals.

1. Visual Inspection of the GFDI.
Remove possible dirt or dust deposits by using a vacuum cleaner or with compressed air.

Functional Test of the GFDI

Switching the GFDI, in deactivated status of the inverter, for mechanically checking the function and for checking the signaling.

2. Switch off F71
 - Failure 201 appears in Sunny Central Control.
3. Switch on F71
 - Failure 201 is confirmed.

i Insulation test of the PV array and connected Sunny Central

The plant operator determines the insulation test of the entire plant.

Replacing the GFDI

In case the mechanical or optical check is not fulfilled or in accordance with the maintenance protocol, if the GFDI must be replaced. Replacement is also necessary after at least after 100 ground faults which led to the tripping of the GFDI.

6.8 Maintaining the Soft Grounding

Maintenance work of the soft grounding is carried out after checking the GFDI. Once tripped, manually reset the failure via the button.

7 Additional Information on Sunny Central 100

7.1 Checking the Transformer and Sinusoidal Filter

i Transformer Connections and Sinusoidal Filter Connections

The transformer connections and sinusoidal filter connections require almost no maintenance work, a visual check is sufficient.

Depending on the model, the switch cabinet of the Sunny Central 100 is initially mounted in two units, later in one unit. In both models, the transformers as well as the sinusoidal filters are mounted separately from the electronics in a separate chamber. Both the transformers and the sinusoidal filters and its connections require little maintenance and are very durable. Nevertheless, you should maintain them in regular intervals to ensure the optimal operation of the plant.

⚠ DANGER

Danger to life due to electric shock or burns by touching live components

- Only work on the device when it is switched off and voltage-free.

The transformer can be found in the right part of the switch cabinet in the separated side chamber. The sinusoidal filter can be found in the rear part of the switch cabinet. The rear panel must be removed for maintenance work.

1. Loosen the screws at the right rear panel and remove the rear panel.
The sine-wave filter can now be accessed.

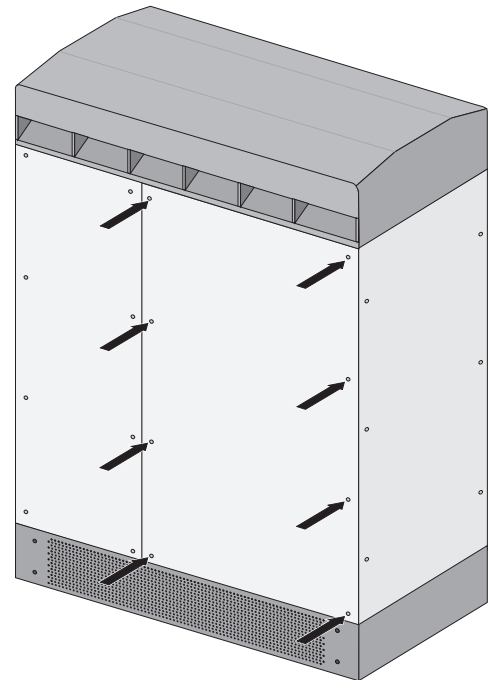

- Loosen the screws at the left rear panel and remove the rear panel.
The transformer can now be accessed.

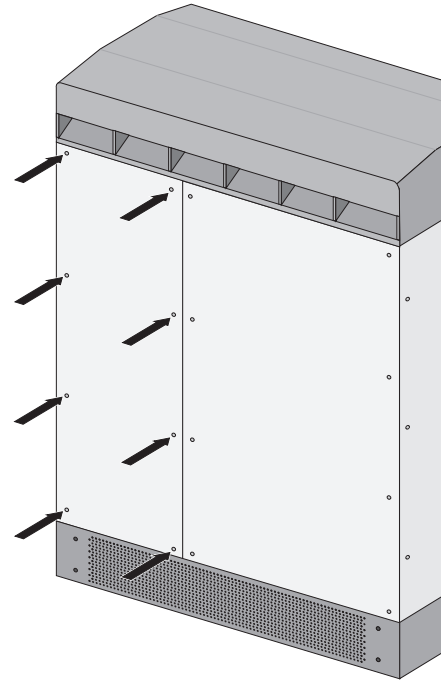

i One-piece rear panel

Switch cabinets of the new construction type have a one-piece rear panel.

- Visually inspect the individual components and make sure there is no corrosion. Grease the contacts of the transformers and the sinusoidal filter connections, if necessary.

7.2 Checking the Cable Feed of the SC 100 outdoor

⚠ DANGER

Danger to life due to electric shock or burns by touching live components

- Only work on the device when it is switched off and voltage-free.

- Check the space between the inverter cabinet and the roof as well as the exhaust air area in the cabinet's base for contamination or damage. An optimal ventilation of the inverter must be ensured at all times.

8 Additional Information on MV Stations

Checking the cable feed of the concrete substations

⚠ DANGER**Danger to life due to electric shock or burns by touching live components**

- Only work on the device when it is switched off and voltage-free.
1. Check the chamber and the air ducts of the concrete substations for contamination or damage.
 - ☑ The cable vault must be dry and dust-free. No insects or other animals may enter the cable vault. Take appropriate measures, if necessary.
 2. Check the ventilation. An optimal ventilation of the inverters must be ensured at all times.
 3. The power grid is supplied via a medium-voltage transformer which requires almost no maintenance work. Regularly check whether oil has leaked.

9 Maintaining the Sunny String-Monitor

The Sunny String-Monitors are usually installed near the modules in the open air. Depending on the system size, an increased number of Sunny String-Monitors is required which must be taken into account during maintenance work. In the following, some steps are listed which serve as maintenance instruction.

⚠ DANGER

Danger to life due to electric shock or burns by touching live components

- Only work on the device when it is switched off and voltage-free.

1. First, check the installation site for accessibility, inflammable materials and stability. Then make sure that the Sunny String-Monitors are installed in a horizontal position and that a sufficient sun shading system is available (e.g., with installations within the PV field).

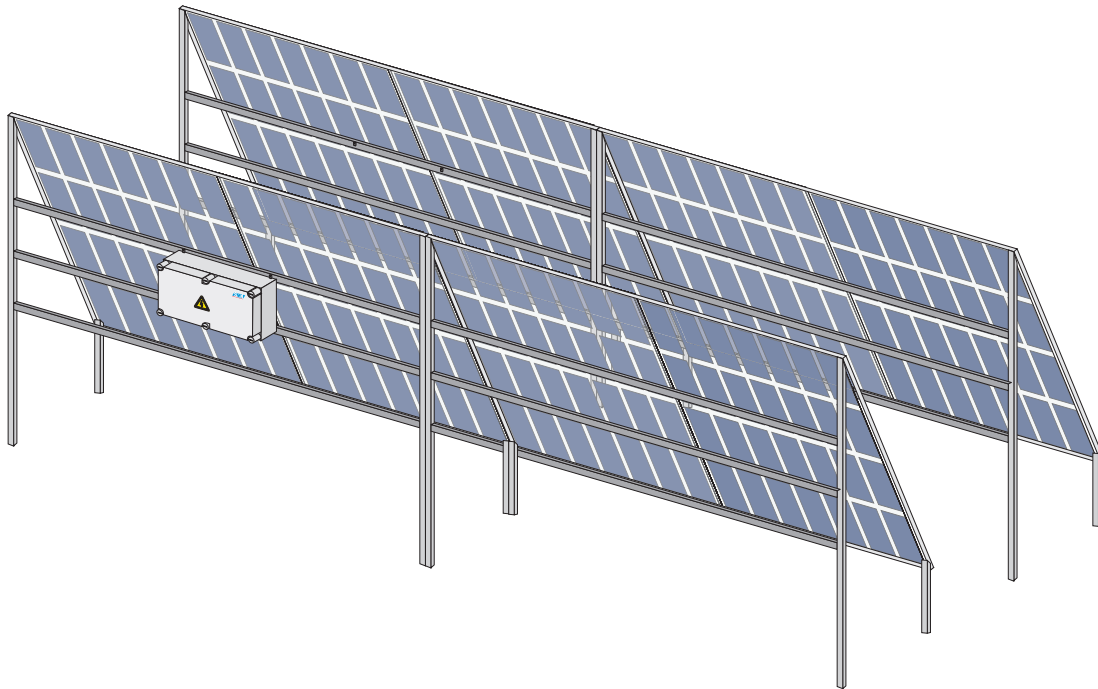

2. Check whether the enclosure is damaged and properly sealed.

3. Make sure that the lid is securely in place and properly sealed. Make sure that the cover locks are correctly closed; they are closed under light pressure by means of a screwdriver until they lock into position (1/4 turning).

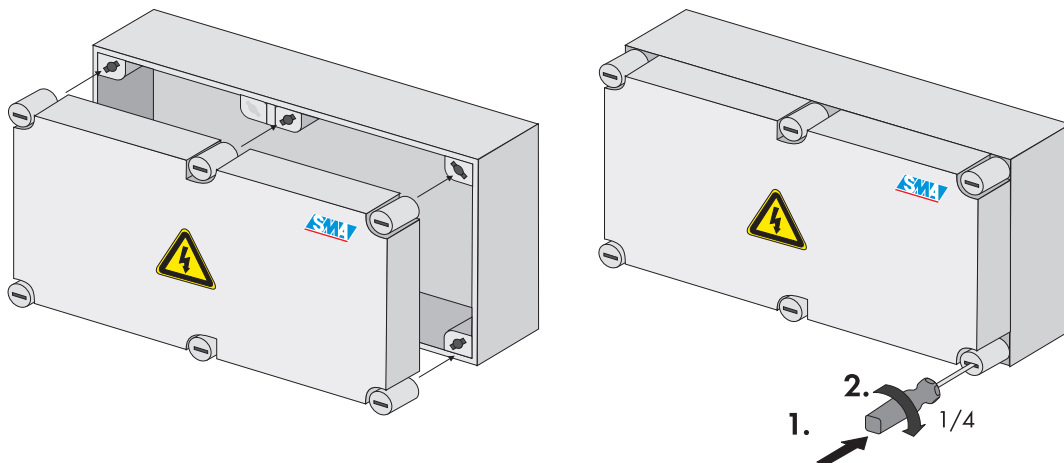

i Maintenance in Sunny String-Monitor

All other steps of maintenance work are carried out inside the Sunny String-Monitor or affect the wiring leading inside.

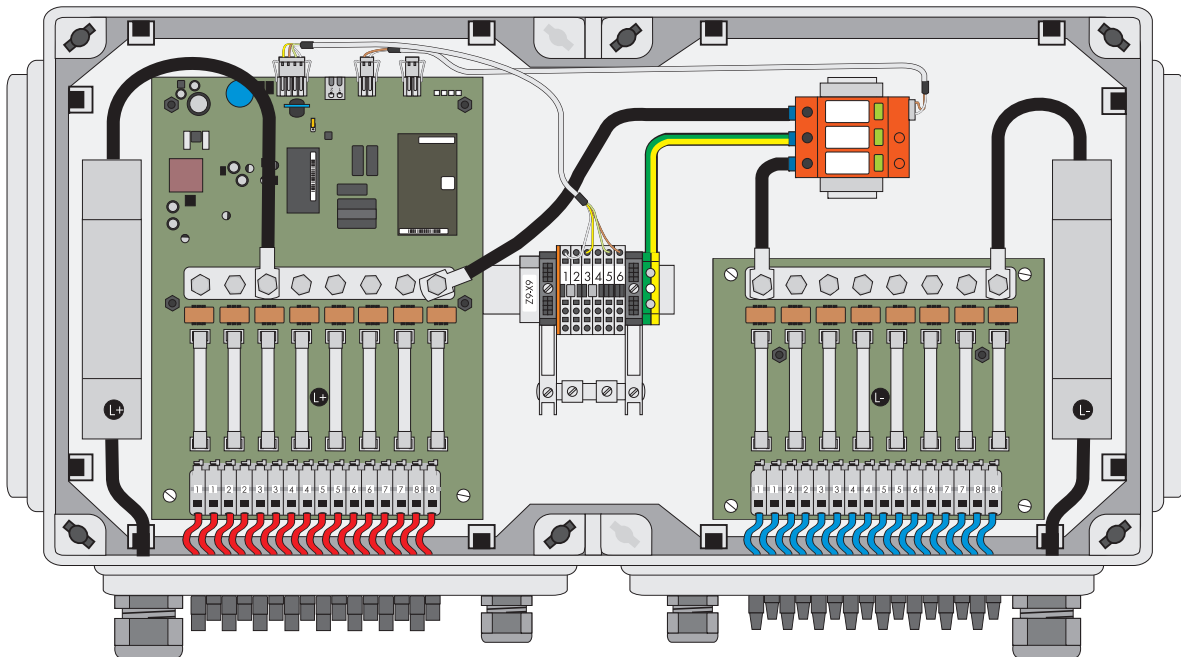

4. Check whether there is condensation water in the device.
 - Wipe out the Sunny String-Monitor, check from where the water intruded the device and take corrective measures.
5. Check the pressure adjusting screw for dirt or damage and replace it, if necessary.
6. Check attachments of Plexiglas covers above the string fuses.
7. Check the safety notices on and in the device and replace them if they are damaged or no longer legible. You can order new labels from SMA Solar Technology AG.
8. Visually check the existing fuses and tension springs on the fuse holders.
9. Check also the auxiliary voltage +55 V at the terminals and connectors. The auxiliary voltage must be at least +30 V.
10. Check all power cable connections for looseness and tighten them if necessary. Check the connectors and insulation for discoloration or degradation. Replace any damaged connectors or corroded contacts.
11. Check all string cable connections for looseness and tighten them if necessary. Check the insulation, and the terminals on the assembly as well on the busbar for discoloration or degradation.

12. Check all cable connections of the optional DC main switch for looseness and tighten them if necessary. Check the insulation and the switch for discoloration or degradation.
13. Check the shield connection of the communication link. It must be hand-tightened; therefore, a screwdriver is not suitable.
14. Check the ground connection and the contact resistance to the ground potential.
15. Check the overvoltage protector, the visual display must be green.

10 Maintaining the Sunny String Monitor-Cabinet

The Sunny String-Monitors are usually installed near the modules in the open air. The larger the plant, the more Sunny String-Monitors are required. This must be taken into account for maintenance work. In the following, some steps are listed which serve as maintenance instruction.

⚠ DANGER

Danger to life due to electric shock or burns by touching live components

- Only work on the device when it is switched off and voltage-free.

1. First, check the installation site for accessibility, inflammable materials and stability. Then make sure that the Sunny String Monitor-Cabinet is installed in a horizontal position and that a sufficient sun shading system is available (e.g. with installations within the PV field).

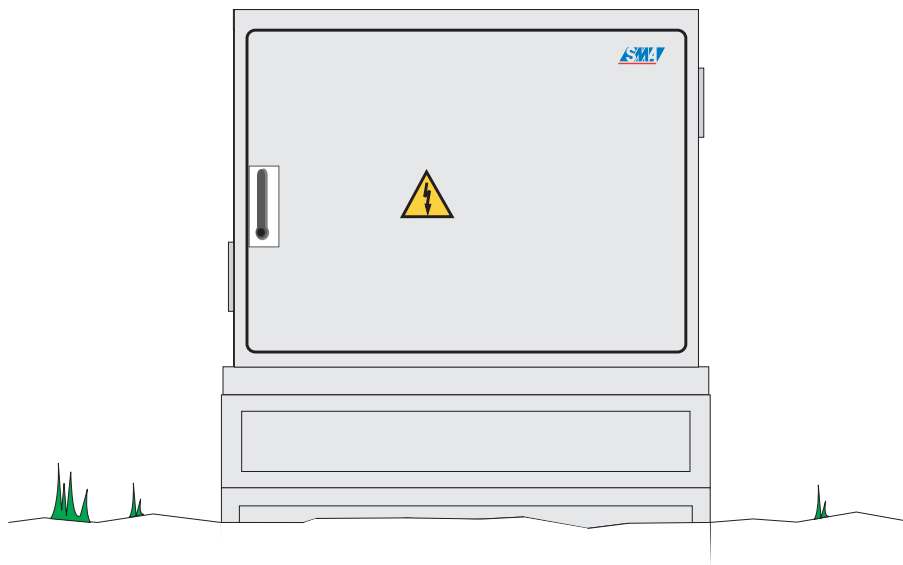

2. Check the enclosure for damage and make sure that the switch cabinet doors as well as the door mechanism are securely positioned and properly sealed.

i Maintenance in the Sunny String Monitor-Cabinet

All other steps of maintenance work are carried out inside the Sunny String-Monitor Cabinet or affect the cabling leading inside.

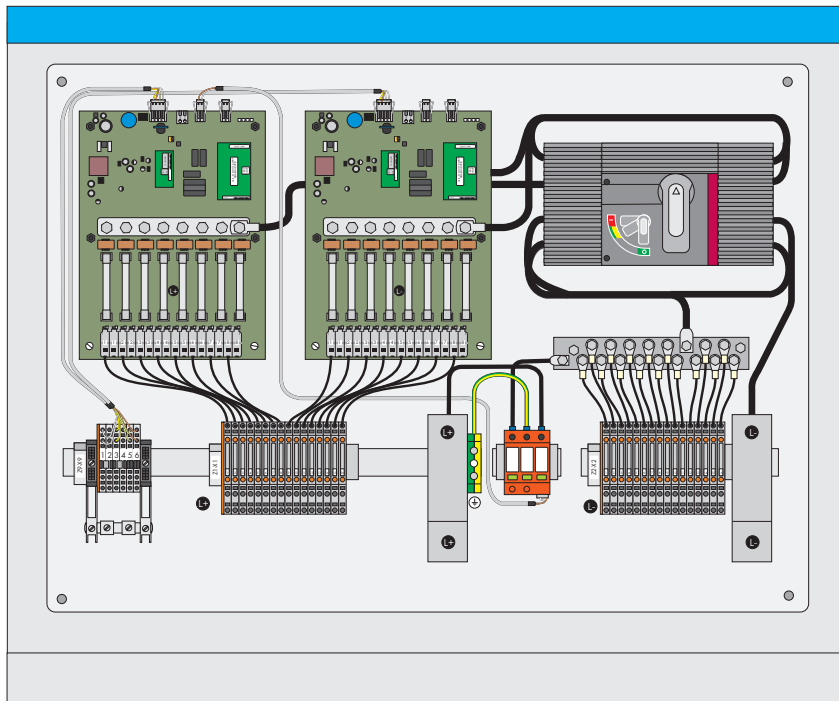

3. Check whether there is condensation water in the device.
 - Wipe out the Sunny String Monitor-Cabinet, check from where the water intruded the device and take corrective measures.
4. Check the attachments of the Plexiglas covers above the string fuses for damage and ensure that they are securely mounted.
5. Check the safety notices on and in the device and replace them if they are damaged or no longer legible. You can order new labels from SMA Solar Technology AG.
6. Visually check the existing fuses and fuse holders.
7. Check also the auxiliary voltage +55 V at the terminals and connectors. The auxiliary voltage must be at least +30 V.
8. Check the entries of the connection cables for dirt, damage and sealing.

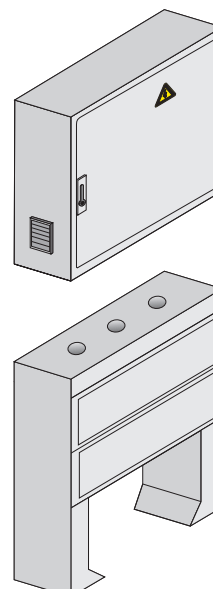

9. Check all power cable connections for looseness and tighten them if necessary. Check the connectors and insulation for discoloration or degradation. Replace any damaged connectors or corroded contacts.
10. Check all string cable connections for looseness and tighten them if necessary. Check the insulation, and the terminals on the assembly as well on the busbar for discoloration or degradation.

11. Check all cable connections of the optional DC main switch for looseness and tighten them if necessary. Check the insulation and the switch for discoloration or degradation.
12. Check the shield connection of the communication cables. The shield connection must only be hand-tightened.
13. Check the ground connection and the contact resistance to the ground potential.
14. Check the surge arrester. The visual display must be green.
15. Check filter pads of the ventilation grill for contamination. Clean or replace it if necessary. Replacement filter pads can be ordered from SMA Solar Technology AG.

11 Maintenance of Sunny String-Monitor SSM24-11

The Sunny String-Monitors are usually installed near the modules in the open air. The larger the plant, the more Sunny String-Monitors are required. This must be taken into account for maintenance work. In the following, some steps are listed which serve as maintenance instruction.

⚠ DANGER

Danger to life due to electric shock or burns by touching live components

- Only work on the device when it is switched off and voltage-free.

⚠ CAUTION

Danger of burn injuries due to hot components.

- Leave the device to cool before starting to work on it.

1. First, check the installation site for accessibility, inflammable materials and positioning or suspension stability. Then make sure that the Sunny String-Monitor is still installed in a horizontal position and that a sufficient sun shading system is available (e.g., with installations directly behind the PV array).

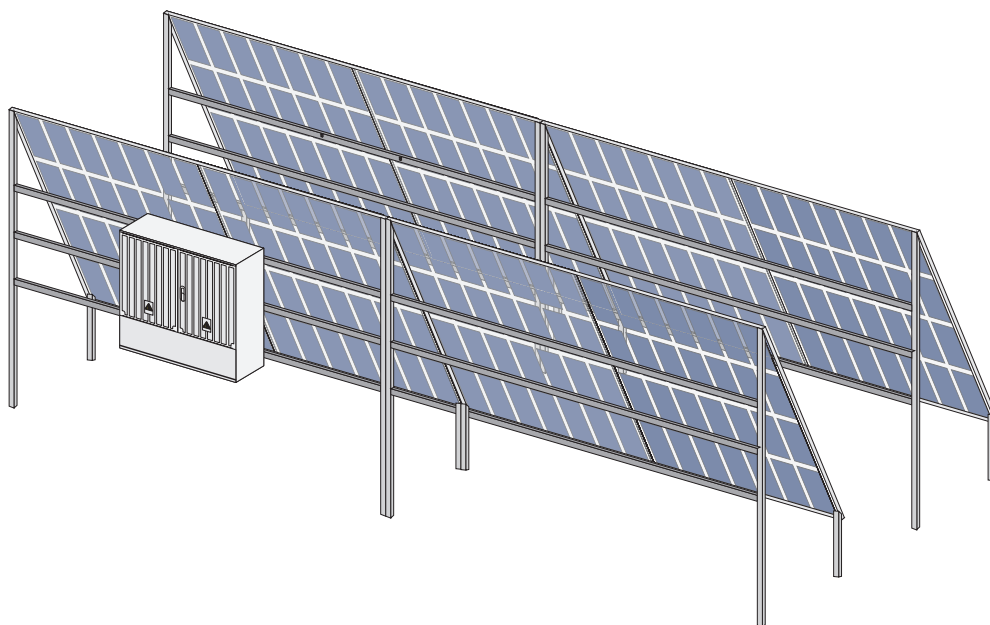

2. Check the enclosure for damage and make sure that the switch cabinet doors as well as the door mechanism are securely positioned and properly sealed.

i Maintenance in Sunny String-Monitor SSM24-11

All other steps of maintenance work are carried out inside the Sunny String-Monitor or affect the cabling leading inside.

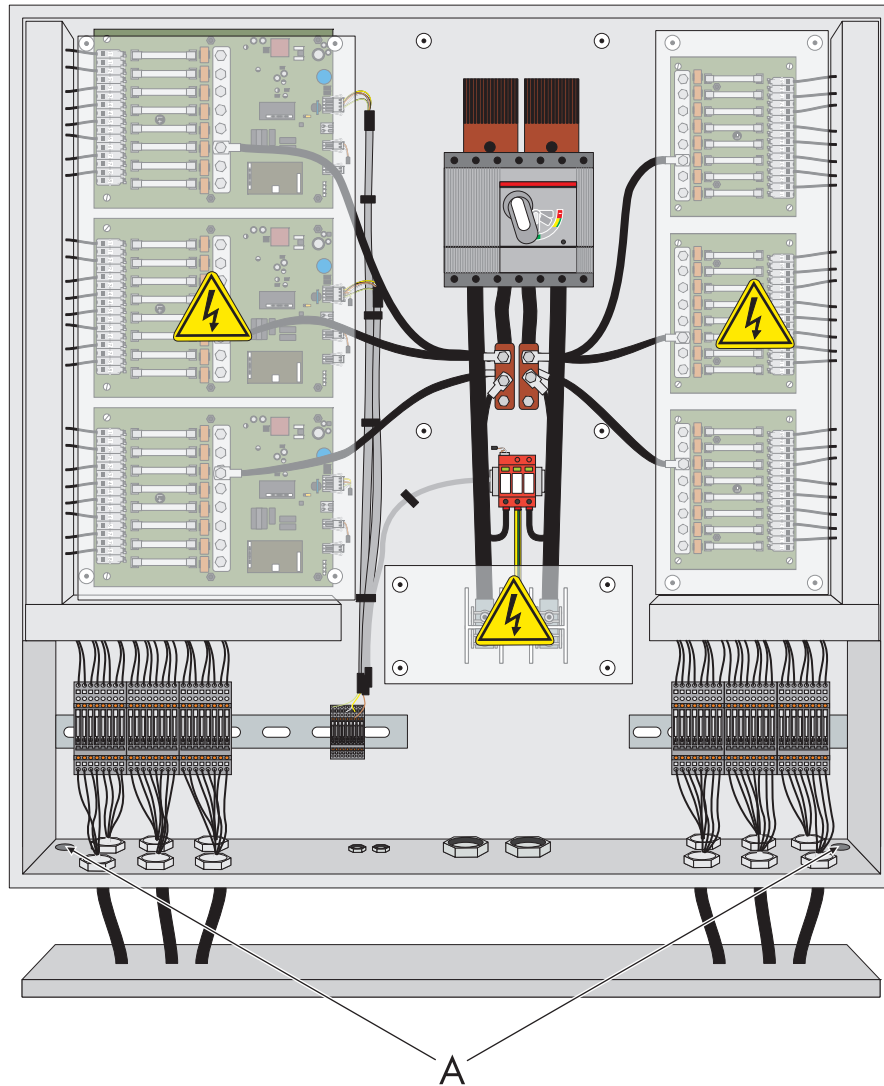

3. Check whether there is condensation water in the device.
4. If there is condensation water in the bottom plate area, clean the two condensation drains (A) in the base of the Sunny String-Monitor.
5. Check the mounting of all Plexiglas covers for damage and ensure that they are securely mounted.
6. Check the safety notices on and in the device and replace them if they are damaged or no longer legible. You can order new labels from SMA Solar Technology AG.
7. Visually check the existing fuses and fuse holders.
8. Check also the auxiliary voltage +55 V at the terminals and connectors. The auxiliary voltage must be at least +30 V.

9. Check the entries of the connection cables for dirt, damage and sealing.

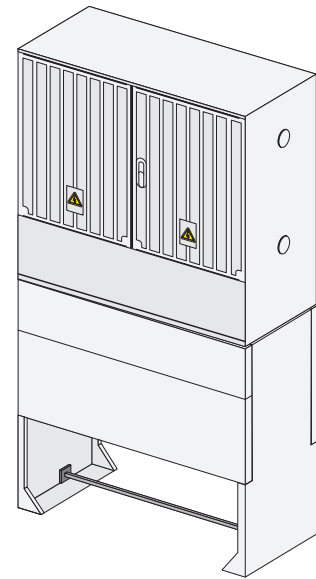

10. Check all power cable connections for looseness and tighten them if necessary. Check the connectors and insulation for discoloration or degradation. Replace any damaged connectors or corroded contacts.
11. Check all string cable connections for looseness and replace defective spring terminals if necessary. Check the insulation, and the terminals on the assembly as well on the busbar for discoloration or degradation.
12. Check all cable connections of the DC main switch for looseness and tighten them if necessary. Check the insulation and the switch for discoloration or degradation.
13. Check the shield connection of the communication cables. The shield connection must only be hand-tightened.
14. Check the ground connection and the contact resistance to the ground potential.
15. Check the surge arrester. The visual display must be green.
16. Check the lateral pressure adjusting screws for dirt.
 - Clean or replace them, if necessary.
- Maintenance of the Sunny String-Monitor SSM24-11 is completed.

12 Maintaining the Sunny Main Box

The Sunny Main Box serves for combining the strings outside the Sunny Central switch cabinet. Usually, the devices are installed close to the Sunny Central on the outside or in a building. Several devices are required depending on the system size. This must be taken into consideration for maintenance work. In the following, some steps are listed which serve as maintenance instruction.

⚠ DANGER**Danger to life due to electric shock or burns by touching live components**

- Only work on the device when it is switched off and voltage-free.

1. Check the installation site for accessibility, inflammable materials and stability. Make sure that the Sunny Main Box is installed in a horizontal position and that the sun shading system is intact.
2. Check the enclosure for damage and make sure that the switch cabinet doors as well as the door mechanism are securely positioned and properly sealed.
3. Check the entries of the connection cables for dirt, damage and sealing.
 - ☑ The Sunny Main Box cabling is securely fastened.
 - ☑ The cabling of the Sunny Main Box is completely foamed in the area of the bottom plate. Ensure that the foam is not porous.
 - ☑ Check the strain relief of the entire cabling.
4. Check whether there is condensation water in the device.
5. Check attachments of Plexiglas covers above the string fuses.
6. Check the safety notices on and in the device and replace them if they are damaged or no longer legible. You can order new labels from SMA Solar Technology AG.
7. Visually check the existing fuses and tension springs on the fuse holders.
8. Check all power cable connections for looseness and tighten them if necessary. Check the insulation and the busbar for discoloration or degradation. Replace any damaged connectors or corroded contacts.
9. Check filter material of the ventilation grill for contamination. Clean or replace it if necessary.

13 Contact

If you have technical problems concerning our products, contact the SMA Service Line. We require the following information in order to provide you with the necessary assistance:

- Inverter type
- Type and number of modules connected
- Type of communication
- Serial number of the Sunny Central
- Sunny Central failure or warning numbers
- Display message on the Sunny Central

You can find your country's contact information at:



<https://go.sma.de/service>

SMA Solar Technology

www.SMA-Solar.com

