

User Manual

SUNNY BOY STORAGE 3.8-US / 5.0-US / 6.0-US

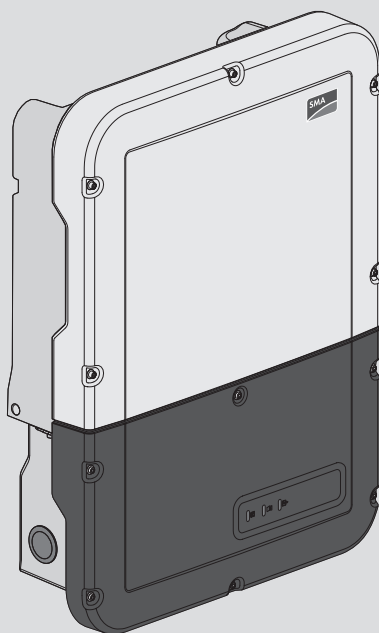

Legal Provisions

The information contained in these documents is the property of SMA Solar Technology AG. No part of this document may be reproduced, stored in a retrieval system, or transmitted, in any form or by any means, be it electronic, mechanical, photographic, magnetic or otherwise, without the prior written permission of SMA Solar Technology AG. Internal reproduction used solely for the purpose of product evaluation or other proper use is allowed and does not require prior approval.

SMA Solar Technology AG makes no representations or warranties, express or implied, with respect to this documentation or any of the equipment and/or software it may describe, including (with no limitation) any implied warranties of utility, merchantability, or fitness for any particular purpose. All such representations or warranties are expressly disclaimed. Neither SMA Solar Technology AG nor its distributors or dealers shall be liable for any indirect, incidental, or consequential damages under any circumstances.

The exclusion of implied warranties may not apply in all cases under some statutes, and thus the above exclusion may not apply.

Specifications are subject to change without notice. Every attempt has been made to make this document complete, accurate and up-to-date. Readers are cautioned, however, that product improvements and field usage experience may cause SMA Solar Technology AG to make changes to these specifications without advance notice, or per contract provisions in those cases where a supply agreement requires advance notice. SMA Solar Technology AG shall not be responsible for any damages, including indirect, incidental or consequential damages, caused by reliance on the material presented, including, but not limited to, omissions, typographical errors, arithmetical errors or listing errors in the content material.

SMA Warranty

You can download the current warranty conditions from the Internet at www.SMA-Solar.com.

Software licenses

The licenses for the used software modules can be called up on the user interface of the product.

Trademarks

All trademarks are recognized, even if not explicitly identified as such. Missing designations do not mean that a product or brand is not a registered trademark.

SMA Solar Technology AG

Sonnenallee 1

34266 Niestetal

Germany

Tel. +49 561 9522-0

Fax +49 561 9522-100

www.SMA.de

Email: info@SMA.de

Status: 4/16/2019

Copyright © 2019 SMA Solar Technology AG. All rights reserved.

Table of Contents

1	Information on this Document	5
1.1	Validity	5
1.2	Target Group	5
1.3	Content and Structure of this Document	5
1.4	Levels of Warning Messages	5
1.5	Symbols in the Document	6
1.6	Typographies in the Document	6
1.7	Designation in the document	6
1.8	Additional Information	7
2	Safety	8
2.1	Intended Use	8
2.2	IMPORTANT SAFETY INSTRUCTIONS	9
3	Product Overview	13
3.1	Product Description	13
3.2	Symbols on the Product	15
3.3	Interfaces and Functions	16
3.4	LED Signals	21
3.5	System Structure	23
4	Operation	25
4.1	Establishing a connection to the user interface	25
4.1.1	Establishing a Direct Connection via Ethernet	25
4.1.2	Establishing a direct connection via WLAN	25
4.1.3	Establishing a Connection via Ethernet in the local network	27
4.1.4	Establishing a Connection via WLAN in the Local Network	28
4.2	Logging In and Out of the User Interface	29
4.3	Start Page Design of the User Interface	30
4.4	Displaying and Downloading the Stored Data	32
4.5	Starting the Installation Assistant	33
4.6	Secure power supply operation	34
4.6.1	Enable secure power supply operation	35
4.6.2	Disable secure power supply operation	35
4.7	Checking or Disabling Battery-Backup Operation	35
4.8	Activate WPS Function	36
4.9	Switching WLAN On and Off	37
4.10	Changing the Password	37
4.11	Changing Operating Parameters	38

- 4.12 Configuring the Country Data Set..... 39
- 4.13 Configuring Feed-In Management..... 39
- 4.14 Configuring the Modbus Function..... 40
- 4.15 Saving the Configuration in a File..... 41
- 4.16 Adopting a Configuration from a File..... 41
- 4.17 Updating the Firmware 42

- 5 Cleaning the Inverter 45**

- 6 Troubleshooting..... 46**
 - 6.1 Forgotten Password..... 46
 - 6.2 Event Messages 47

- 7 Compliance Information 86**

- 8 Contact 87**

1 Information on this Document

1.1 Validity

This document is valid for:

- SBS3.8-US-10 (Sunny Boy Storage 3.8-US) from firmware version 1.50.10.R.
- SBS5.0-US-10 (Sunny Boy Storage 5.0-US) from firmware version 1.50.10.R.
- SBS6.0-US-10 (Sunny Boy Storage 6.0-US) from firmware version 1.50.10.R.

1.2 Target Group

This document is intended for qualified persons and end users. Only qualified persons are allowed to perform the activities marked in this document with a warning symbol and the caption "Qualified person". Tasks that do not require any particular qualification are not marked and can also be performed by end users. Qualified persons must have the following skills:

- Knowledge of how batteries work and are operated
- Training in how to deal with the dangers and risks associated with installing, repairing and using electrical devices, batteries and installations
- Training in the installation and commissioning of electrical devices and installations
- Knowledge of all applicable laws, standards and directives
- Knowledge of and compliance with this document and all safety information
- Knowledge of and compliance with the documents of the battery manufacturer with all safety information

1.3 Content and Structure of this Document

This document describes the configuration, operation and troubleshooting of the product as well as the operation of the product user interface.

You will find the latest version of this document and further information on the product in PDF format and as eManual at www.SMA-Solar.com. You can also call up the eManual via the user interface of the product.

Illustrations in this document are reduced to the essential information and may deviate from the real product.

1.4 Levels of Warning Messages

The following levels of warning messages may occur when handling the product.

DANGER

Indicates a hazardous situation which, if not avoided, will result in death or serious injury.

WARNING

Indicates a hazardous situation which, if not avoided, could result in death or serious injury.



⚠ CAUTION

Indicates a hazardous situation which, if not avoided, could result in minor or moderate injury.

NOTICE

Indicates a situation which, if not avoided, can result in property damage.

1.5 Symbols in the Document

Symbol	Explanation
	Information that is important for a specific topic or goal, but is not safety-relevant
<input type="checkbox"/>	Indicates a requirement for meeting a specific goal
<input checked="" type="checkbox"/>	Desired result
x	A problem that might occur
	Example

1.6 Typographies in the Document

Typography	Use	Example
bold	<ul style="list-style-type: none"> Messages Terminals Elements on a user interface Elements to be selected Elements to be entered 	<ul style="list-style-type: none"> Connect the insulated conductors to the terminals X703:1 to X703:6. Enter 10 in the field Minutes.
>	<ul style="list-style-type: none"> Connects several elements to be selected 	<ul style="list-style-type: none"> Select Settings > Date.
[Button] [Key]	<ul style="list-style-type: none"> Button or key to be selected or pressed 	<ul style="list-style-type: none"> Select [Enter].

1.7 Designation in the document

Complete designation	Designation in this document
SMA Solar Technology AG	SMA
Sunny Boy Storage	Inverter, product

1.8 Additional Information

For more information, please go to www.SMA-Solar.com.

Title and information content	Type of information
Mounting, installation, commissioning and decommissioning	Installation manual
"Approved batteries and battery communication connection" Overview of approved batteries	Technical Information
"Application for SMA Grid Guard Code"	Form
"Efficiency and Derating" Efficiency and derating behavior of the SMA inverters	Technical Information
"Grid Support Utility Interactive Inverters" Information about how to activate and to set the grid supporting features according to UL 1741 SA	Technical Information
"Parameters and Measured Values" Overview of all inverter operating parameters and their configuration options	Technical Information
"SMA and SunSpec Modbus® Interface" Information on the Modbus interface	Technical Information
"Modbus® parameters and measured values" Device-specific register HTML file	Technical Information

2 Safety

2.1 Intended Use

The Sunny Boy Storage is an AC-coupled battery inverter for parallel grid and stand-alone mode operation. The Sunny Boy Storage converts the direct current supplied by a battery into grid-compliant alternating current. The Sunny Boy Storage, together with a battery and a compatible energy meter, make up a system for increased self-consumption (Flexible Storage System) or, together with a automatic transfer switch compatible with Sunny Boy Storage, a battery-backup system (Flexible Storage System with battery-backup function).

The product is suitable for indoor and outdoor use.

The product must only be operated in connection with an intrinsically safe lithium-ion battery approved by SMA Solar Technology AG. An updated list of batteries approved by SMA Solar Technology AG is available at www.SMA-Solar.com.

The battery must comply with UL 1973 and must be intrinsically safe.

The communication interface of the battery used must be compatible with the product. The entire battery voltage range must be completely within the permissible input voltage range of the product. The maximum permissible DC input voltage of the product must not be exceeded.

All components must remain within their permitted operating ranges and their installation requirements at all times.

The product is approved for the US and Canadian market.

The product may only be operated with one of the energy meters approved by SMA Solar Technology AG. The following energy meters are allowed to be used when operating this product:

- WattNode Modbus energy meter

The product may only be operated in battery-backup systems using an automatic transfer switching device approved by SMA Solar Technology AG. You are not allowed to build automatic transfer switching devices for operation with this product by yourself on the basis of a circuit diagram.

The following automatic transfer switching devices are allowed to be used when operating this product:

- SBS-ABU-200-US-10 / BUUM3-US-10 (Automatic Backup Unit) from SMA Solar Technology AG

Use SMA products only in accordance with the information provided in the enclosed documentation and with the locally applicable laws, regulations, standards and directives. Any other application may cause personal injury or property damage.

Alterations to the SMA products, e.g., changes or modifications, are only permitted with the express written permission of SMA Solar Technology AG. Unauthorized alterations will void guarantee and warranty claims and in most cases terminate the operating license. SMA Solar Technology AG shall not be held liable for any damage caused by such changes.

Any use of the product other than that described in the Intended Use section does not qualify as the intended use.

The enclosed documentation is an integral part of this product. Keep the documentation in a convenient, dry place for future reference and observe all instructions contained therein.

This document does not replace and is not intended to replace any local, state, provincial, federal or national laws, regulations or codes applicable to the installation, electrical safety and use of the product. SMA Solar Technology AG assumes no responsibility for the compliance or non-compliance with such laws or codes in connection with the installation of the product.

The type label must remain permanently attached to the product.

2.2 IMPORTANT SAFETY INSTRUCTIONS

SAVE THESE INSTRUCTIONS

This section contains safety information that must be observed at all times when working.

The product has been designed and tested in accordance with international safety requirements. As with all electrical or electronic devices, there are residual risks despite careful construction. To prevent personal injury and property damage and to ensure long-term operation of the product, read this section carefully and observe all safety information at all times.

DANGER

Danger to life due to electric shock when live components or DC conductors are touched

The DC conductors connected to a battery may be live. Touching live DC conductors results in death or serious injury due to electric shock.

- Disconnect the product and battery from voltage sources and make sure it cannot be reconnected before working on the device.
- Do not touch non-insulated parts or cables.
- Do not remove the terminal block with the connected DC conductors from the slot under load.
- Wear suitable personal protective equipment for all work on the product.
- Observe all safety information of the battery manufacturer.

DANGER

Danger to life due to electric shock in case of overvoltages and if surge protection is missing

Overvoltages (e. g. in the event of a flash of lightning) can be further conducted into the building and to other connected devices in the same network via the network cables or other data cables if there is no surge protection. Touching live parts and cables results in death or lethal injuries due to electric shock.

- Ensure that all devices in the same network and the battery are integrated into the existing surge protection.
- When laying the network cables or other data cables outdoors, it must be ensured that a suitable surge protection device is provided at the transition point of the cable from the product or the battery outdoors to the inside of a building.
- The Ethernet interface of the inverter is classified as "TNV-1" and offers protection against overvoltages of up to 1.5 kV.

⚠ WARNING**Danger to life due to fire or explosion**

In rare cases, an explosive gas mixture can be generated inside the product under fault conditions. In this state, switching operations can cause a fire or explosion. Death or lethal injuries due to fire or flying debris can result.

- In case of error, only carry out corrective measures specified by SMA Solar Technology AG (see Section 6 "Troubleshooting", page 46). If no corrective measures are specified, do not perform any actions on the product. Contact the Service.
- Ensure that unauthorized persons have no access to the product.
- Disconnect the AC circuit breaker and secure it against reconnection.
- Disconnect the battery from the product via an external disconnection device.

⚠ WARNING**Danger to life due to fire or explosion when batteries are fully discharged**

A fire may occur due to incorrect charging of fully discharged batteries. This can result in death or serious injury.

- Before commissioning the system, verify that the battery is not fully discharged.
- Do not commission the system if the battery is fully discharged.
- If the battery is fully discharged, contact the battery manufacturer for further proceedings.
- Only charge fully discharged batteries as instructed by the battery manufacturer.

⚠ WARNING**Danger to life due to burns caused by electric arcs through short-circuit currents**

Short-circuit currents in the battery can cause heat build-up and electric arcs. Heat build-up and electric arcs may result in lethal injuries due to burns.

- Disconnect the battery from all voltages sources prior to performing any work on the battery.
- Observe all safety information of the battery manufacturer.

⚠ CAUTION**Risk of burns from hot surfaces**

The surface of the inverter can get very hot. Touching the surface can result in burns.

- Mount the inverter in such a way that it cannot be touched inadvertently.
- Do not touch hot surfaces.
- Wait 30 minutes for the surface to cool sufficiently.
- Observe the safety messages on the inverter.

⚠ CAUTION

Risk of injury due to weight of product

Injuries may result if the product is lifted incorrectly or dropped while being transported or mounted.

- Transport and lift the product carefully. Take the weight of the product into account.
- Wear suitable personal protective equipment for all work on the product.

NOTICE

Damage to the enclosure seal in subfreezing conditions

If you open the product or disconnect the Power Unit and Connection Unit when temperatures are below freezing, the enclosure seals can be damaged. Moisture can penetrate the product and damage it.

- Only open the product if the ambient temperature is not below 0°C (32°F).
- If a layer of ice has formed on the enclosure seal when temperatures are below freezing, remove it prior to opening the product (e.g. by melting the ice with warm air). Observe the applicable safety regulations.
- Do not disassemble the Power Unit and Connection Unit unless the ambient temperature is at least 0°C (32°F) and conditions are frost-free.

NOTICE

Damage to the product due to sand, dust and moisture ingress

Sand, dust and moisture penetration can damage the product and impair its functionality.

- Only open the product if the humidity is within the thresholds and the environment is free of sand and dust.
- Do not open the product during a dust storm or precipitation.
- Close tightly all enclosure openings.
- Only use listed rain-tight or liquid-tight conduit fittings to attach the conduits to the product.

NOTICE

Damage due to cleaning agents

The use of cleaning agents may cause damage to the product and its components.

- Clean the product and all its components only with a cloth moistened with clear water.

NOTICE

Damage to the inverter due to electrostatic discharge

Touching electronic components can cause damage to or destroy the inverter through electrostatic discharge.

- Ground yourself before touching any component.

NOTICE**Destruction of the measuring device due to overvoltage**

- Only use measuring devices with a DC input voltage range of 600 V or higher.

i Electrical installations (for North America)

All installations must conform with the laws, regulations, codes and standards applicable in the jurisdiction of installation (e.g. *National Electrical Code*® ANSI/NFPA 70 or *Canadian Electrical Code*® CSA-C22.1.).

- Before connecting the product to the utility grid, contact your local grid operator. The electrical connection of the product must be carried out by qualified persons only.
- Ensure that the cables or conductors used for electrical connection are not damaged.

3 Product Overview

3.1 Product Description

The Sunny Boy Storage uses the connected battery for the intermediate storage of excess PV energy in the SMA Flexible Storage System. For this purpose, the Sunny Boy Storage receives the feed-in and purchased energy data from the energy meter. This data is used by the Sunny Boy Storage to control the charging and discharging of the battery.

The use of an automatic transfer switching device is required in the battery-backup system. In the event of grid failure, the automatic transfer switching device disconnects the PV system, loads and the Sunny Boy Storage from the utility grid and creates a battery-backup grid. The battery-backup grid supplies loads that should continue to be supplied with electricity in the event of grid failure. In the event of grid failure, the Sunny Boy Storage supplies the loads with energy after a short switching time. The PV system supplies additional energy that can be used to supply the loads and charge the battery.

The use of an automatic transfer switching device is not required in limited battery-backup systems. To build a limited battery-backup system, you must attach an outlet and a switch to the inverter. You can connect a load to the outlet, which should continue to be supplied with power from the battery in the event of grid failure. The secure power supply operation is not automatically enabled in the event of a grid failure, neither is it automatically disabled once the utility grid is available again. During secure power supply operation, the load can only be supplied with energy as long as there is stored energy available in the battery.

Secure power supply operation in Flexible Storage Systems with backup power supply not possible

If the inverter is used in a battery-backup system and connected with an automatic transfer switch, the secure power supply operation is not available.

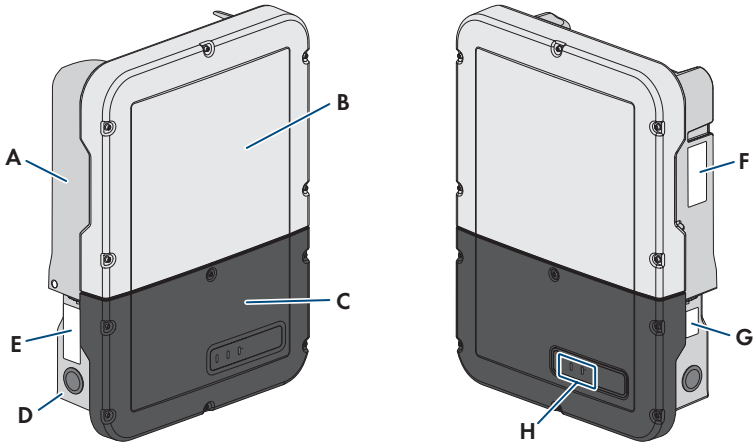











Figure 1: Design of the inverter

Position	Designation
A	Power Unit
B	Enclosure lid of the Power Unit
C	Enclosure lid for the Connection Unit
D	Connection Unit
E	Warning label with compliance information
F	Type label The type label uniquely identifies the inverter. The type label must remain permanently attached to the product. You will find the following information on the type label: <ul style="list-style-type: none"> • Inverter device type (Model) • Serial number of the Power Unit (Serial No. Power Unit or S/N Power Unit) • Date of manufacture • Device-specific characteristics

Position	Designation
G	<p>Additional type label</p> <p>The additional type label must remain permanently attached to the product. You will find the following information on the additional type label:</p> <ul style="list-style-type: none"> • Device type (Model) • Inverter serial number (Serial number device or S/N device) • Identification key (PIC) for registration in Sunny Portal • Registration ID (RID) for registration in Sunny Portal • WLAN password (WPA2-PSK) for the direct connection to the user interface of the inverter via WLAN
H	<p>LEDs</p> <p>The LEDs indicate the operating state of the inverter.</p>

3.2 Symbols on the Product

Symbol	Explanation
	<p>Beware of electrical voltage</p> <p>The product operates at high voltages.</p>
	<p>Beware of hot surface</p> <p>The product can get hot during operation.</p>
	<p>Observe the documentation</p> <p>Observe all documentation supplied with the product.</p>
	<p>Observe the documentation</p> <p>Together with the red LED, this symbol indicates an error.</p>
	<p>Inverter</p> <p>Together with the green LED, this symbol indicates the operating state of the inverter.</p>
	<p>Data transmission</p> <p>Together with the blue LED, this symbol indicates the status of the network connection.</p>
	<p>Equipment Grounding Terminal</p> <p>This symbol indicates the position for the connection of an equipment grounding conductor.</p>

Symbol	Explanation
	The product is has no galvanic isolation.
	UL 1741 and CSA C22.2 No. 107.1 are the standards applied by Underwriters Laboratories to the product to certify that it meets the requirements of the <i>National Electrical Code</i> ®, the <i>Canadian Electrical Code</i> ® and IEEE 1547.

3.3 Interfaces and Functions

The inverter can be equipped or retrofitted with the following interfaces and functions:

User interface for monitoring and configuration

The product is equipped as standard with an integrated webserver, which provides a user interface for configuring and monitoring the product. The product user interface can be called up via the web browser if there is an existing connection to an end device (e.g. computer, tablet PC or smartphone).

Smart Inverter Screen

The Smart Inverter Screen enables you to view the status display and to display the nominal energy throughput and state of charge of the battery on the user interface login page. You therefore have an overview of the most important inverter and battery data without having to log into the user interface.

The Smart Inverter Screen is deactivated by default. The Smart Inverter Screen can be activated via the user interface once the inverter has been commissioned.

SMA Speedwire

The product is equipped with SMA Speedwire as standard. SMA Speedwire is a type of communication based on the Ethernet standard. SMA Speedwire is designed for a data transfer rate of 100 Mbps and enables optimum communication between Speedwire devices within systems.

Class 1 wiring methods are to be used for field wiring connection to the terminals of the communication interface.

SMA Webconnect

The inverter is equipped with a Webconnect function as standard. The Webconnect function enables direct data transmission between the inverters and Internet portals Sunny Portal and Sunny Places without any additional communication device and for a maximum of 1 inverters per visualized system. In PV systems with more than 1 inverters, there is the option of establishing data transmission between the inverters and Sunny Portal via the data logger (e.g., SMA Data Manager) or distributing the inverters over several systems. If there is an existing WLAN or Ethernet connection, you can directly access your visualized system via the web browser on your end device.

WLAN

The product is equipped with a WLAN interface as standard. The inverter is delivered with the WLAN interface activated as standard. If you do not want to use WLAN, you can deactivate the WLAN interface.

In addition, the product has a WPS function. The WPS function is for automatically connecting the product to a network (e.g. via router) and establish a direct connection between the product and an end device.

Modbus

The product is equipped with two Modbus interfaces.

One interface can be controlled via Ethernet and the other interface via RS485. The Modbus interface via Ethernet is designed for industrial use – via SCADA systems, for example – and deactivated as standard. The Modbus interface via Ethernet must be configured via the user interface of the inverter (if necessary). The Modbus interface via RS485 is used for data exchanges with an energy meter. The Modbus interface via RS485 must be configured via the user interface of the inverter and set on the energy meter accordingly.

The Modbus interface via Ethernet has the following tasks:

- Remote query of measured values
- Remote setting of operating parameters
- Setpoint specifications for system control
- Controlling the battery

Grid Management Services

The inverter is a grid support multi-mode inverter.

The inverter was tested in accordance with the UL 1741 SA (2016-09-07) to be compliant with the source requirements documents of the states available at the time. For connecting the inverter to the utility grid, no additional grid monitoring equipment is necessary. A description of the tested functions and instructions on the activation and setting of functions can be found in the technical information "Grid Support Utility Interactive Inverters" at www.SMA-Solar.com.

Secure power supply operation

In case of a grid failure, the secure power supply operation supplies the loads with energy from the battery. You can connect a standard outlet (120 V) and a standard switch to the inverter. You can connect a load with a maximum of 16 A and 120 V to the emergency power outlet. The load is supplied with energy from the battery during grid failure. The switch is used to enable and disable secure power supply operation.

The secure power supply operation is not automatically enabled in the event of a grid failure, neither is it automatically disabled once the utility grid is available again. If the utility grid fails, the load supply must be enabled manually by activating the switch. The inverter automatically regulates the energy supply of the outlet after activating the switch. When the utility grid is available again and the load can be supplied by this again, the secure power supply operation must be disabled manually by switching the switch off.

During active secure power supply operation, the inverter is disconnected from the building's main electrical system and does not therefore feed into the utility grid. During secure power supply operation, the load can only be supplied with energy as long as there is stored energy available in the battery. If there is insufficient energy available from the battery, the secure power supply operation remains active, even if the utility grid is available again. Switching over to supplying the load from the utility grid is not carried out automatically.

i **Secure power supply operation in Flexible Storage Systems with backup power supply not possible**

If the inverter is used in a battery-backup system and connected with an automatic transfer switch, the secure power supply operation is not available.

i **Do not connect any loads that require an uninterrupted energy supply**

The secure power supply operation and the battery-backup operation may not be used for loads that require an uninterrupted energy supply. The energy that is available during the secure power supply operation or battery-backup operation depends on the battery capacity available and the state of charge of the battery (SOC).

- Do not connect loads if they are dependent on an uninterrupted energy supply for reliable operation.

Battery-backup function

The inverter is equipped with a battery-backup function. The battery-backup function is disabled by default and must be enabled via the user interface. The battery-backup function can only be enabled if the inverter is operated in a battery-backup system with an automatic transfer switching device. If the system is retrofitted with an automatic transfer switching device, the battery configuration must be reset and carried out once again. Then the battery-backup system must be configured. The configuration is carried out via the installation assistant on the user interface of the battery inverter.

The battery-backup function ensures that the inverter forms a battery-backup grid that uses energy from the battery and the PV system to supply the household grid in the event of a utility grid failure. When the battery-backup operation is activated, the automatic transfer switch disconnects the PV system and the household grid from the utility grid in the event of a grid failure, and connects these to the battery-backup grid. After a short switch-over time, the battery-backup grid and loads connected can be supplied by the battery and supplemented with energy from the PV system. The charging of the battery is ensured by the existing PV system during battery-backup operation. The charging process of the battery (initiated by the PV system) can be deactivated via a certain parameter during battery-backup operation. As soon as the utility grid is available again, the battery-backup operation is disabled automatically and the loads are supplied with energy from the utility grid. If the automatic battery-backup operation is not set, the battery-backup operation must be manually enabled in the event of a grid failure, and must also be disabled again once the utility grid is available (information in terms of switching operations of the automatic transfer switch and procedures during grid failure and grid reconnection see planning guidelines "SMA FLEXIBLE STORAGE SYSTEM with Battery-Backup Function").

When the utility grid is down and the battery fully discharged, there is, in the beginning, not enough power available to create a stable battery-backup grid. In this case, the battery must be charged by the PV system. The battery inverter is able to create a stable battery-backup grid only when enough power is available in the battery. To use battery charging power from the PV system, the battery inverter has to create a stand-alone grid. For this purpose, the battery inverter requires energy from the battery reserve. If enough PV power is available, the PV inverters start automatically and the battery is charged with energy from the PV system. The battery is charged with energy until the battery inverter is able to provide a battery-backup grid. By setting parameters, it is possible to define up to which state of charge the battery is charged and discharged. If not enough PV energy is available to start the PV inverters, the stand-alone grid breaks down. Two hours later, the battery inverter tries to start the PV inverter again to charge the battery with energy from the PV system. If the battery inverter still fails to create a stand-alone grid after several attempts due to insufficient PV energy, the battery inverter and battery switch to sleep mode. In this case, a manual black start is required to switch the battery inverter and battery from sleep mode back to operation.

i Secure power supply operation in Flexible Storage Systems with backup power supply not possible

If the inverter is used in a battery-backup system and connected with an automatic transfer switch, the secure power supply operation is not available.

i Do not connect any loads that require an uninterrupted energy supply

The secure power supply operation and the battery-backup operation may not be used for loads that require an uninterrupted energy supply. The energy that is available during the secure power supply operation or battery-backup operation depends on the battery capacity available and the state of charge of the battery (SOC).

- Do not connect loads if they are dependent on an uninterrupted energy supply for reliable operation.

Black start function

The inverter has a black start function and an auxiliary battery that provides energy for the black start. In battery-backup systems, you have the possibility to install a standard switch for black starting the inverter and battery. The black-start switch is used to start the battery-backup operation manually in the event of grid failure if the battery and inverter are in sleep mode and, therefore, are unable to provide energy. When the black-start switch is switched on manually, the energy from the auxiliary battery is made available in order to automatically switch the battery and therefore also the inverter from sleep mode to operation in order that the inverter can make energy available from the battery. You can stop the battery-backup operation by switching it off manually. To enable the black-start function, at least one battery must be connected to input A.

Multi-battery device

The product is equipped with the multi-battery function as standard from firmware version 1.50.10.R. The multi-battery function enables to charge and discharge several batteries of the same or different type. If the system is extended by one or several batteries or one battery is replaced, the battery configuration must be reset and carried out again. The configuration is carried out via the installation assistant on the user interface of the battery inverter. An overview of batteries approved by SMA Solar Technology AG and their possible combinations is available at www.SMA-Solar.com.

SMA Smart Connected

SMA Smart Connected is the free monitoring of the inverter via the SMA Sunny Portal. Thanks to SMA Smart Connected, the PV system operator and qualified person will be informed automatically and proactively about inverter events that occur.

SMA Smart Connected is activated during registration in Sunny Portal. In order to use SMA Smart Connected, it is necessary that the inverter is permanently connected to Sunny Portal and the data of the PV system operator and qualified person is stored in Sunny Portal and up-to-date.

Time-of-Use

With the "Time-of-Use" function, you can adjust the charging behavior of the battery to your electricity tariff. Energy bills are thus reduced and electricity at lower cost can be used. You can determine in which time range the battery with a specified charging power is operated. At specific times, this is mostly useful when the battery's state of charge has to take on a certain value or the tariff situation makes the charging more attractive, regardless of the power at the grid-connection point. The charging parameters set in the power profile are only limited by the state of charge (SOC). At times when the "Time-of-Use" function is not enabled, the battery is charged correspondent to the increased self-consumption for the entire system. The "Time-of-Use" function is disabled by default and must be enabled by creating power profiles.

Peak load shaving

With the "Peak Load Shaving" function, you can optimize the behavior of the battery inverter with respect to the power exchange at the grid-connection point. This is mostly useful when a higher supply of energy would lead to a higher electricity cost. With the "Peak Load Shaving" function, certain grid-exchange power outputs to which the battery inverter is adjusted depending on its power and battery capacity available can be set. Power peaks can thus be avoided.

You can configure times and setpoints for the power drawn at the grid-connection point. When the loads require additional energy, the battery is discharged and the maximum value is kept constant at the grid-connection point. This is based on the prerequisite that the battery is sufficiently charged. At times when the "Peak Load Shaving" function is not activated, the battery is charged or discharged correspondent to the increased self-consumption for the entire system. The "Peak Load Shaving" function is deactivated by default and must be activated by creating power profiles.

Frequency Shift Power Control

If PV inverters are connected on the AC side during battery-backup operation, the battery inverter must be able to limit their output power. This limitation becomes necessary when, for example, the battery inverter's battery is fully charged and the power available from the PV system exceeds the power requirement of the connected loads.

To prevent excess energy from overcharging the battery, the battery inverter automatically detects the problem and changes the frequency at the AC output. This frequency adjustment is analyzed by the PV inverter. As soon as the power frequency of the battery-backup grid increases beyond the value specified in **f Start Delta**, the PV inverter limits its output power accordingly.

The frequency shift power control is enabled by default. No additional settings must be carried out. It must be ensured that the connected PV inverters limit their power at the AC output via the battery inverter due to changes in frequency. The frequency-dependent active power limitation $P(f)$ must be set in the PV inverter.

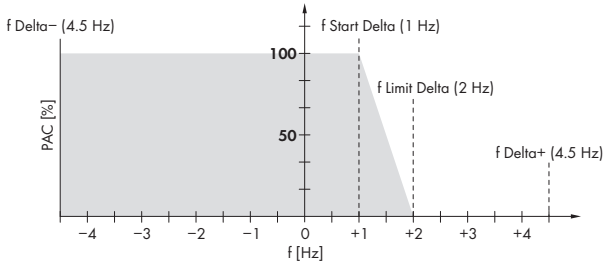

Figure 2: Impact of the frequency shift power control on the power output of a PV inverter

Designation	Explanation
f	Base frequency of the stand-alone grid
f Delta- to f Delta+	Maximum range in relation to the base frequency in which the PV inverter is active.
f Start Delta	Frequency increase in relation to the base frequency, at which point the power regulation via frequency begins.
f Limit Delta	Frequency increase in relation to the base frequency, at which point the power regulation via frequency ends. The power of the PV inverter at this point is 0 W.

3.4 LED Signals

LED signal	Explanation
The green LED is flashing (two seconds on and two seconds off)	Waiting for feed-in conditions The conditions for feed-in operation are not yet met. As soon as the conditions are met, the inverter will start feed-in operation.
The green LED is flashing (1.5 s on and 0.5 s off)	Secure power supply operation or battery-backup operation The secure power supply operation or battery-backup operation is enabled and the inverter supplies the loads with energy from the battery.
The green LED flashes quickly	Update of central processing unit The central processing unit of the inverter is being updated.

LED signal	Explanation
The green LED is glowing	Parallel grid operation
The green LED is off	The inverter is not feeding into the utility grid.
The red LED is glowing	Event occurred If an event occurs, a distinct event message and the corresponding event number will be displayed in addition on the inverter user interface or in the communication product (e.g. SMA Data Manager).
The blue LED flashes slowly for approx. one minute	Communication connection is being established The inverter is establishing a connection to a local network or is establishing a direct connection to an end device via Ethernet (e.g. computer, tablet PC or smartphone).
The blue LED flashes quickly for approx. two minutes (0.25 s on and 0.25 s off).	WPS active The WPS function is active.
The blue LED is glowing	Communication active There is an active connection with a local network or there is a direct connection with an end device via Ethernet (e.g. computer, tablet PC or smartphone).

3.5 System Structure

Flexible Storage System

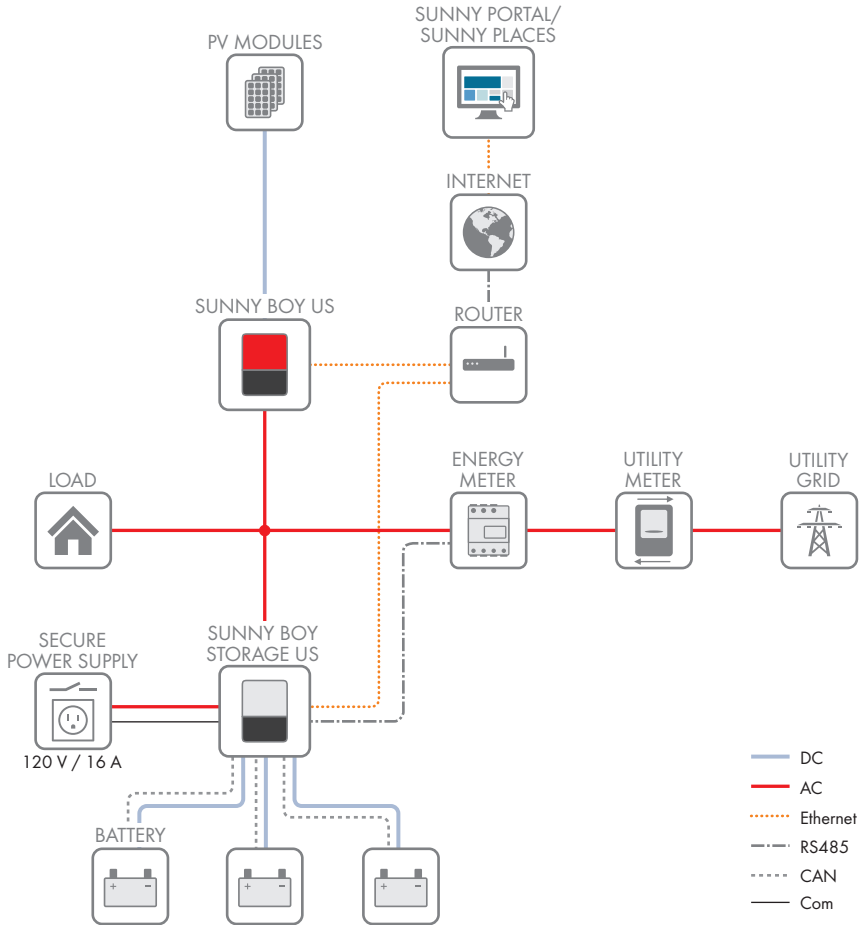

Figure 3: System design of a flexible storage system with switch and outlet for secure power supply operation (example)

SMA Flexible Storage System with Battery-Backup Function

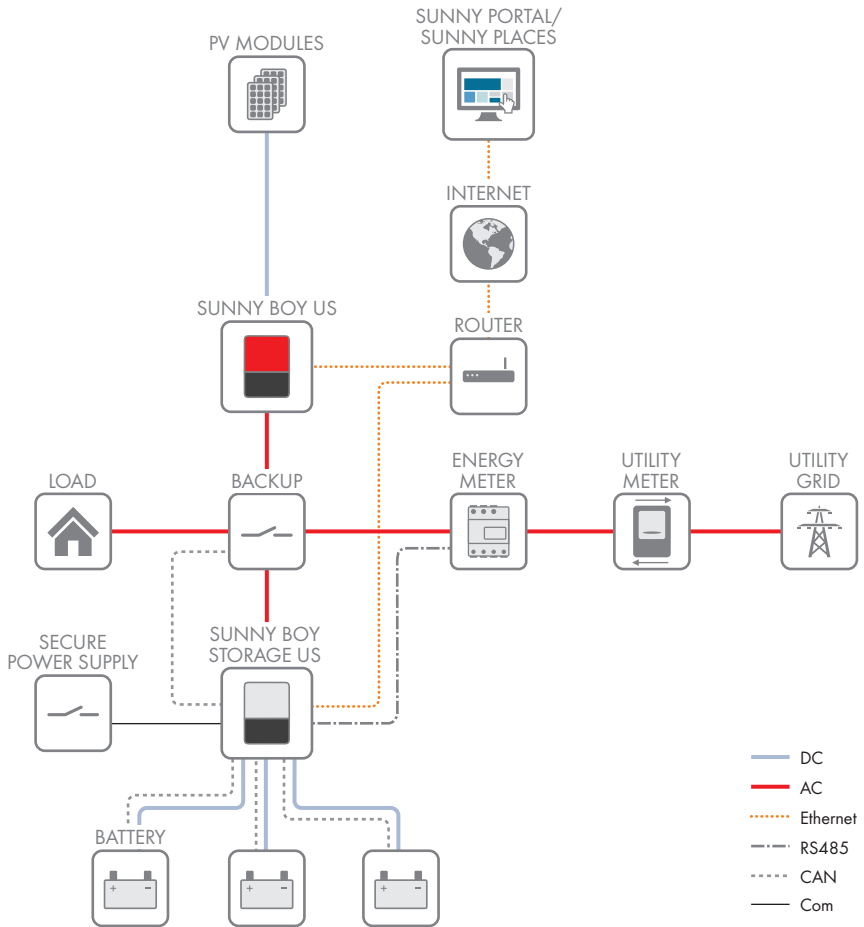

Figure 4: System design of a flexible storage system with battery-backup function (example) You can find a circuitry overview in the documentation of the automatic transfer switching device.

4 Operation

4.1 Establishing a connection to the user interface

4.1.1 Establishing a Direct Connection via Ethernet

Requirements:

- The product must be commissioned.
- An end device (e.g. computer) with an Ethernet interface must be available.
- The product must be connected directly to the end device.
- The respective latest version of one of the following web browsers must be installed: Chrome, Edge, Firefox, Internet Explorer or Safari.
- The SMA Grid Guard code of the Installer must be available for the changing of grid-relevant settings after completion of the first ten feed-in hours or installation assistant (see "Application for SMA Grid Guard Code" at www.SMA-Solar.com).

i IP address of the inverter

- Standard inverter IP address for direct connection via Ethernet: 169.254.12.3

Procedure:

1. Open the web browser of your device, enter the IP address **169.254.12.3** in the address line and press the enter key.
 2. **i Web browser signals a security vulnerability**
 After the IP address has been confirmed by pressing the enter key, a message might appear indicating that the connection to the user interface of the inverter is not secure. SMA Solar Technology AG guarantees that calling up the user interface is secure.
 - Continue loading the user interface.
- The login page of the user interface opens.

4.1.2 Establishing a direct connection via WLAN

Requirements:

- The product must be commissioned.
- An end device (e.g. computer, tablet PC or smartphone) must be available.
- The respective latest version of one of the following web browsers must be installed: Chrome, Edge, Firefox, Internet Explorer or Safari.
- JavaScript must be enabled in the web browser of the end device.
- The SMA Grid Guard code of the Installer must be available for the changing of grid-relevant settings after completion of the first ten feed-in hours or installation assistant (see "Application for SMA Grid Guard Code" at www.SMA-Solar.com).

i SSID, IP address and necessary passwords

- SSID in WLAN: SMA[serial number] (e.g. SMA0123456789)
- Standard WLAN password (usable until completion of the configuration by means of the installation assistant or prior to the end of the first ten feed-in hours): SMA12345
- Device-specific WLAN password (usable after initial configuration and completion of the first ten feed-in hours): see WPA2-PSK on the type label of the inverter or on the back of the manual included in the delivery
- Standard IP address for a direct connection via WLAN outside of a local network:
192.168.12.3

i Importing and exporting files with end devices having an iOS operating system is not possible.

For technical reasons, importing and exporting files (e.g. importing an inverter configuration, saving the current inverter configuration or exporting events and parameters) is not possible with mobile end devices having an iOS operating system.

- Use an end device that does not have an iOS operating system for importing and exporting files.

The procedure can be different depending on the end devices. If the procedure described does not apply to your end device, establish the direct connection via WLAN as described in the manual of your end device.

Procedure:

1. If your end device has a WPS function:
 - Activate the WPS function on the inverter. To do this, tap twice on the enclosure lid of the Connection Unit.
 - The blue LED flashes quickly for approx. two minutes. The WPS function is active during this time.
 - Activate the WPS on your end device.
 - The connection with your end device will be established automatically. It can take up to 20 seconds for this connection to be established.
2. If your end device does not have a WPS function:
 - Search for WLAN networks with your end device.
 - Select the SSID of the inverter **SMA[serial number]** in the list with the found WLAN networks.
 - Enter the inverter WLAN password. Within the first ten feed-in hours and prior to completing the configuration by means of the installation assistant, you must use the standard WLAN password **SMA12345**. After the first ten feed-in hours or after completing the configuration by means of the installation assistant, you must use the device-specific WLAN password (WPA2-PSK) of the inverter. You find the WLAN password (WPA2-PSK) on the type label.
3. Enter the IP address **192.168.12.3** or, if your device supports mDNS services, **SMA[serial number].local** or **https://SMA[serial number]** in the address bar of the web browser and press the enter key.

4. **i** Web browser signals a security vulnerability

After the IP address has been confirmed by pressing the enter key, a message might appear indicating that the connection to the user interface of the inverter is not secure. SMA Solar Technology AG guarantees that calling up the user interface is secure.

- Continue loading the user interface.
- The login page of the user interface opens.

4.1.3 Establishing a Connection via Ethernet in the local network

i New IP address for connecting with a local network

If the product is connected to a local network (e.g. via a router), the product will receive a new IP address. Depending on the type of configuration, the new IP address will be assigned automatically by the DHCP server (router) or manually by you. Upon completion of the configuration, the product can only be reached via the following access addresses:

- Generally applicable access address: IP address manually assigned or assigned by the DHCP server (router) (identification via network scanner software or network configuration of the router).
- Access address for Apple and Linux systems: SMA[serial number].local (e.g. SMA0123456789.local)
- Access address for Windows and Android systems: https://SMA[serial number] (e.g. https://SMA0123456789)

Requirements:

- The product must be connected to the local network via a network cable (e.g. via a router).
- The product must be integrated into the local network. Tip: There are various methods of integrating the product into the local network with the aid of the installation assistant.
- An end device (e.g. computer, tablet PC or smartphone) must be available.
- The end device must be in the same local network as the product.
- The respective latest version of one of the following web browsers must be installed: Chrome, Edge, Firefox, Internet Explorer or Safari.
- The SMA Grid Guard code of the Installer must be available for the changing of grid-relevant settings after completion of the first ten feed-in hours or installation assistant (see "Application for SMA Grid Guard Code" at www.SMA-Solar.com).

Procedure:

1. Open the web browser of your end device, enter the IP address of the inverter in the address line of the web browser and press the enter key.

2. **i** Web browser signals a security vulnerability

After the IP address has been confirmed by pressing the enter key, a message might appear indicating that the connection to the user interface of the inverter is not secure. SMA Solar Technology AG guarantees that calling up the user interface is secure.

- Continue loading the user interface.

The login page of the user interface opens.

4.1.4 Establishing a Connection via WLAN in the Local Network

i New IP address for connecting with a local network

If the product is connected to a local network (e.g. via a router), the product will receive a new IP address. Depending on the type of configuration, the new IP address will be assigned automatically by the DHCP server (router) or manually by you. Upon completion of the configuration, the product can only be reached via the following access addresses:

- Generally applicable access address: IP address manually assigned or assigned by the DHCP server (router) (identification via network scanner software or network configuration of the router).
- Access address for Apple and Linux systems: SMA[serial number].local (e.g. SMA0123456789.local)
- Access address for Windows and Android systems: https://SMA[serial number] (e.g. https://SMA0123456789)

Requirements:

- The product must be commissioned.
- The product must be integrated into the local network. Tip: There are various methods of integrating the product into the local network with the aid of the installation assistant.
- An end device (e.g. computer, tablet PC or smartphone) must be available.
- The end device must be in the same local network as the product.
- The respective latest version of one of the following web browsers must be installed: Chrome, Edge, Firefox, Internet Explorer or Safari.
- The SMA Grid Guard code of the Installer must be available for the changing of grid-relevant settings after completion of the first ten feed-in hours or installation assistant (see "Application for SMA Grid Guard Code" at www.SMA-Solar.com).

i Importing and exporting files with end devices having an iOS operating system is not possible.

For technical reasons, importing and exporting files (e.g. importing an inverter configuration, saving the current inverter configuration or exporting events and parameters) is not possible with mobile end devices having an iOS operating system.

- Use an end device that does not have an iOS operating system for importing and exporting files.

Procedure:

1. Enter the IP address of the inverter in the address bar of the web browser.

2. **Web browser signals a security vulnerability**

After the IP address has been confirmed by pressing the enter key, a message might appear indicating that the connection to the user interface of the inverter is not secure. SMA Solar Technology AG guarantees that calling up the user interface is secure.

- Continue loading the user interface.
- The login page of the user interface opens.

4.2 Logging In and Out of the User Interface

After a connection to the user interface of the inverter has been established, the login page opens. Log onto the user interface as described below.

Usage of cookies

For the correct display of the user interface, cookies are required. The cookies are used for convenience only. By using this user interface you agree to the placement of cookies.

Log in as Installer or User for the First Time

Password for PV systems that are registered in a communication product

The password for the user group **Installer** is also the system password. If you assign a password for the user group **Installer** via the user interface of the inverter, the password must match the PV system password. If the new password for logging onto the user interface does not match the system password in the communication product, the inverter cannot be reached by the communication product.

- A uniform password is assigned for all Speedwire devices in the PV system.

Procedure:

1. In the drop-down list **Language**, select the desired language.
 2. In the **User group** drop-down list, select the entry **Installer** or **User**.
 3. In the **New password** field, enter a new password for the selected user group.
 4. In the **Repeat password** field, enter the new password again.
 5. Select **Login**.
- The **Configuring the Inverter** page opens.

Log in as the User or Installer

1. In the drop-down list **Language**, select the desired language.
 2. In the **User group** drop-down list, select the entry **Installer** or **User**.
 3. Enter the password in the field **Password**.
 4. Select **Login**.
- The start page of the user interface opens.

Log Out as the User or Installer

1. On the right-hand side of the menu bar, select the menu **User Settings**.
 2. In the subsequent context menu, select [**Logout**].
- The login page of the user interface opens. The logout was successful.

4.3 Start Page Design of the User Interface

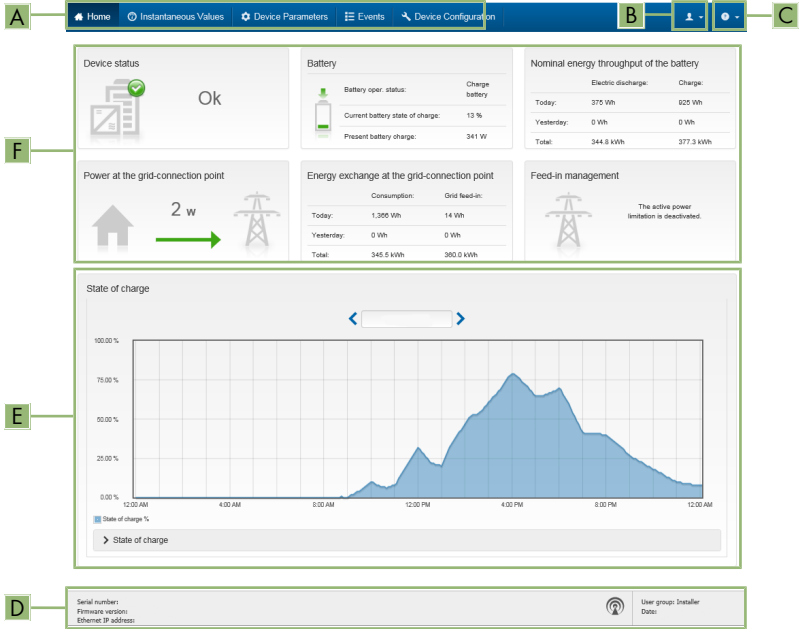

Figure 5: Design of the user interface's start page (example)

Position	Designation	Description
A	Menu	<p>Provides the following functions:</p> <ul style="list-style-type: none"> • Home Opens the user interface homepage • Instantaneous values Current measured values of the inverter • Device Parameters The various operating parameters of the inverter can be viewed and configured here depending on the user group. • Events All events that have occurred in the selected time period are displayed here. The event types are Information, Warning and Error. Currently existing events of the types Error and Warning will be additionally displayed in the Device status viewlet. However, only the higher-priority event is displayed. If, for example, there is a Warning and an Error present at the same time, only the Error will be displayed. • Device configuration Various settings for the inverter can be made here. The selection available is dependent on which user group you are logged in as and the operating system of the device with which the user interface has been called up. • Data You will find all data that is saved in the internal memory of the inverter or on an external storage medium on this page.
B	User settings	<p>Provides the following functions, depending on the user group logged in:</p> <ul style="list-style-type: none"> • Starting the installation assistant • SMA Grid Guard login • Logout
C	Help	<p>Provides the following functions:</p> <ul style="list-style-type: none"> • Displaying information on Open Source licenses used • Link to the website of SMA Solar Technology AG

Position	Designation	Description
D	Status bar	<p>Displays the following information:</p> <ul style="list-style-type: none"> • Inverter serial number • Inverter firmware version • IP address of the inverter within the local network and/or IP address of the inverter during WLAN connection • With WLAN connection: Signal strength of WLAN connection • User group logged in • Date and device time of the inverter
E	State of charge	<p>Chronological sequence of the state of charge (SOC) of the battery This value may be different from the values that the battery provides. Only the value supplied by the inverter is used for this purpose.</p>
F	Status display	<p>The various areas display information on the current status of the system.</p> <ul style="list-style-type: none"> • Device status Displays whether the inverter and/or the battery is/are currently in a fault-free operating state or whether there is an event type Error or Warning present. • Feed-in management Displays whether the inverter is currently limiting its active power. • Nominal energy throughput of the battery Indicates how much energy has been charged to the battery and how much has been discharged from the battery. • Battery Displays the following information: <ul style="list-style-type: none"> - Operating status of battery - Current battery state of charge - Current battery charging power • Energy exchange at the grid-connection point Indicates how much energy was obtained from the utility grid to supply the household and how much the PV system fed in. • Power at the grid-connection point Indicates which power is currently fed in or obtained at the grid-connection point.

4.4 Displaying and Downloading the Stored Data

If an external storage device is plugged in, you can display and download the stored data.

Procedure:

1. Activate the user interface (see Section 4.1, page 25).

2. Log into the user interface (see Section 4.2, page 29).
3. Select the menu **Data**.
4. Select the folder **Data**.
5. To call up the data, select the respective folder and click on the required file.
6. To download the data, select the data type to be exported in the drop-down list. Then apply the time filter and select **Data export**.

4.5 Starting the Installation Assistant

QUALIFIED PERSON

The installation assistant leads you step-by-step through the steps necessary for the initial configuration of the inverter.

Layout of the installation assistant

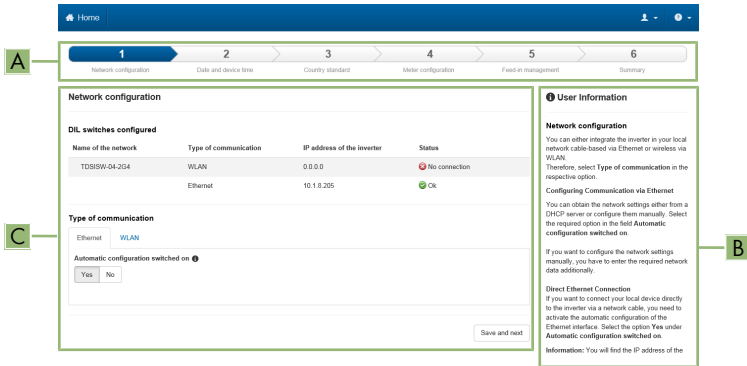

Figure 6: Layout of the installation assistant (example)

Position	Designation	Description
A	Configuration steps	Overview of the installation assistant steps. The number of steps depends on the type of device and the additionally installed modules. The current step is highlighted in blue.
B	User information	Information about the current configuration step and the setting options of the configuration step.
C	Configuration field	You can make settings in this field.

Requirement:

- When configuring after completion of the first ten feed-in hours or after exiting the installation assistant, the SMA Grid Guard code must be available in order to change the grid-relevant parameters (see "Application for SMA Grid Guard Code" at www.SMA-Solar.com).

Procedure:

1. Open the user interface (see Section 4.1, page 25).
 2. Log in as **Installer**.
 3. Select the menu **User Settings** (see Section 4.3, page 30) on the start page of the user interface.
 4. In the context menu, select [**Starting the installation assistant**].
- The installation assistant will open.

4.6 Secure power supply operation

If an electrical outlet and a switch for secure power supply operation are connected to the inverter, you can supply a load with energy from the battery in case of a grid failure.

The secure power supply operation is not automatically enabled in the event of a grid failure, neither is it automatically disabled once the utility grid is available again. If the utility grid fails, the load supply must be enabled manually by activating the switch. The inverter automatically regulates the energy supply of the outlet after activating the switch. When the utility grid is available again and the load can be supplied by this again, the secure power supply operation must be disabled manually by switching the switch off.

If you enable the secure power supply operation, the inverter supplies the loads that are connected to the outlet for secure power supply operation until the battery's state of charge (SOC) has reached the lower limit. In case the battery's state of charge (SOC) is too low, the energy supply of the outlet is permanently interrupted. The lower state of charge limit can be modified by setting a parameter. The lower limit is 0% by default. The secure power supply operation runs only when the battery can be recharged after connecting to the utility grid.

In case of overload, the energy supply of the outlet is briefly interrupted. The inverter automatically attempts to reestablish the energy supply 20 seconds after the interruption. This can lead to inadvertent starting of the load that is connected to the outlet. Ensure that the load connected to the outlet does not consume too much power. If necessary, reduce the power consumption of the load.

During active secure power supply operation, the inverter is disconnected from the building's main electrical system and does not therefore feed into the utility grid. During secure power supply operation, the load can only be supplied with energy as long as there is stored energy available in the battery. If there is insufficient energy available from the battery, the secure power supply operation remains active, even if the utility grid is available again. Switching over to supplying the load from the utility grid is not carried out automatically. Once the battery is sufficiently recharged and the load can be supplied, the secure power supply operation must be restarted.

Secure power supply operation in Flexible Storage Systems with backup power supply not possible

If the inverter is used in a battery-backup system and connected with an automatic transfer switch, the secure power supply operation is not available.

i Do not connect any loads that require an uninterrupted energy supply

The secure power supply operation and the battery-backup operation may not be used for loads that require a uninterrupted energy supply. The energy that is available during the secure power supply operation or battery-backup operation depends on the battery capacity available and the state of charge of the battery (SOC).

- Do not connect loads if they are dependent on an uninterrupted energy supply for reliable operation.

4.6.1 Enable secure power supply operation

To supply the loads with energy in the event of utility grid failure, you can enable the secure power supply operation as follows.

To check the secure power supply operation, proceed as described in this section. Disable the secure power supply operation afterwards (see Section 4.6.2, page 35).

Procedure:

1. If no load is connected to the outlet, connect a load.
2. Turn the switch of the outlet to secure power supply operation.
3. Wait one minute.
 - The inverter commences secure power supply operation. Once the inverter supplies the outlet, the green LED flashes (1.5 s on and 0.5 s off).
4. If the green LED is not flashing, it is likely that the battery's state of charge (SOC) is too low and the following steps must be performed:
 - Ensure that the outlet's switch is set to secure power supply operation.
 - Connect a load with lower power consumption to the outlet.
5. If no voltage can be measured at the outlet, ensure that the switch of the outlet is set to secure power supply operation, and that the switch, outlet and control light for secure power supply operation are correctly connected.

4.6.2 Disable secure power supply operation

1. If necessary, disconnect the load from the outlet.
2. Turn the switch of the outlet to grid operation.
 - Grid operation is activated.
- The inverter connects to the utility grid and starts feed-in operation.

4.7 Checking or Disabling Battery-Backup Operation

You may check the battery-backup operation. This ensures that the battery-backup system works and provides a battery-backup grid in the event of utility grid failure.

The basic procedure for changing operating parameters is explained in another section (see Section 4.11 "Changing Operating Parameters", page 38).

Procedure:

1. Select the parameter **Backup box operating mode** and set it to **Force**.
 - The battery-backup operation is started.
2. To ensure that the battery-backup system works, proceed as follows: check loads, select the menu **[Results]** and check whether a battery-backup system error is displayed. During battery-backup operation, the loads must be supplied with energy from the battery-backup system. If the loads are supplied with energy, an error has occurred. If an error is displayed in the menu **[Results]**, it must be fixed.
3. To finish the check, set the parameter **Backup box operating mode** to **Auto**.
4. To disable the battery-backup operation, set the parameter **Backup box operating mode** to **Off**. The battery-backup operation is disabled until it is re-enabled manually. The battery-backup operation is enabled when it is set to **Auto**.

4.8 Activate WPS Function

The WPS function can be used for different purposes:

- Automatic connection to a network (e.g. via router)
- Direct connection between the product and an end device

Depending on the intended application of the WPS function, the procedure for activation will vary.

Activating WPS function for automatic connection to a network

Requirements:

- WLAN must be activated in the product.
- WPS must be activated on the router.

Procedure:

1. Activate the user interface (see Section 4.1, page 25).
 2. Log in as **Installer**.
 3. Start the installation assistant (see Section 4.5, page 33).
 4. Select **Network configuration**.
 5. Select **WPS for WLAN network** button in the **WLAN** tab.
 6. Select **Activate WPS**.
 7. Select **Save and next** and exit the installation assistant.
- The WPS function is activated and the automatic connection to the network can be established.

Activating the WPS function for direct connection to the end device.

- Activate the WPS function on the inverter. To do this, tap twice on the enclosure lid of the Connection Unit.
 - The blue LED flashes quickly for approx. two minutes. The WPS function is active during this time.

4.9 Switching WLAN On and Off

The inverter is equipped with an activated WLAN interface as standard. If you do not want to use WLAN, you can switch the WLAN function off and switch it on again whenever needed. In doing so, you can switch the WLAN direct connection and the WLAN connection in the local network on independently of each other.

Switching on the WLAN function only possible via Ethernet connection

If you switch off both the WLAN function for the direct connection and for the connection in the local network, access to the inverter user interface and therefore reactivation of the WLAN interface is only possible via an Ethernet connection.

The basic procedure for changing operating parameters is explained in another section (see Section 4.11 "Changing Operating Parameters", page 38).

Switching WLAN Off

If you would like to switch the WLAN function off completely, you must switch off both the direct connection and the connection in the local network.

Procedure:

- To switch off the direct connection in the parameter group **PV system communication > WLAN**, select the parameter **Soft-access-point is turned on** and set this to **No**.
- To switch off the connection in the local network in the parameter group **PV system communication > WLAN**, select the parameter **WLAN is turned on** and set this to **No**.

Switching WLAN On

If you have switched the WLAN function for direct connection or for connection in the local network off, you can switch the WLAN function back on in accordance with the following procedure.

Requirement:

- If the WLAN function was previously switched off completely, the inverter must be connected to a computer or router via Ethernet.

Procedure:

- To switch on the WLAN direct connection, in the parameter group **PV system communication > WLAN**, select the parameter **Soft-access-point is turned on** and set this to **Yes**.
- To switch on the WLAN connection in the local network, in the parameter group **System communication > WLAN**, select the parameter **WLAN is turned on** and set this to **Yes**.

4.10 Changing the Password

The password for the inverter can be changed for both user groups. Furthermore, the user group **Installer** can change the password for the user group **User** as well as its own password.

Procedure:

1. Activate the user interface (see Section 4.1, page 25).
2. Log into the user interface (see Section 4.2, page 29).

3. Call up the menu **Device Parameters**.
4. Select [**Edit parameters**].
5. In the parameter group **User Rights > Access Control** change the password of the desired user group.
6. Select [**Save all**] to save the changes.

4.11 Changing Operating Parameters

The operating parameters of the inverter are set to certain values by default. You can change the operating parameters to optimize the performance of the inverter.

This section describes the basic procedure for changing operating parameters. Always change operating parameters as described in this section. Some function-sensitive parameters can only be viewed by qualified persons and can only be changed by qualified persons by entering the personal SMA Grid Guard code.

Requirements:

- Changes to grid-relevant parameters must be approved by the responsible grid operator.
- Changes to grid-relevant parameters must be approved by the responsible grid operator.

Procedure:

1. Activate the user interface (see Section 4.1, page 25).
 2. Log into the user interface (see Section 4.2, page 29).
 3. Call up the menu **Device Parameters**.
 4. Select [**Edit parameters**].
 5. Log in using the SMA Grid Guard code to change those parameters designated by a lock (only for installers):
 - Select the menu **User Settings** (see Section 4.3, page 30).
 - In the subsequent context menu, select [**SMA Grid Guard login**].
 - Enter the SMA Grid Guard code and select [**Login**].
 6. Expand the parameter group that contains the parameter which is to be configured.
 7. Change the desired parameters.
 8. Select [**Save all**] to save the changes.
- The inverter parameters are set.

Accepting the settings

Saving the made settings is indicated by an hourglass symbol on the user interface. If the DC voltage is sufficient, the data is transferred directly to the inverter and accepted. If the DC voltage is too low (e.g. when the battery is switched off), the settings are saved, but they cannot be directly transferred to or accepted by the inverter. As long as the inverter has not yet received and accepted the settings, the hourglass symbol will continue to be displayed on the user interface. The settings will be accepted when there is sufficient DC voltage applied and the inverter restarts. As soon as the hourglass symbol appears on the user interface, the settings have been saved. The settings will not be lost. You can log off of the user interface and leave the system.

4.12 Configuring the Country Data Set

⚠ QUALIFIED PERSON

The basic procedure for changing operating parameters is explained in another section (see Section 4.11 "Changing Operating Parameters", page 38).

Procedure:

- In the parameter group **Grid monitoring > Grid monitoring** select the parameter **Set country standard** and set the required country data set.

4.13 Configuring Feed-In Management

⚠ QUALIFIED PERSON

Starting the installation assistant

1. Activate the user interface (see Section 4.1, page 25).
2. Log in as **Installer**.
3. Start the installation assistant (see Section 4.5, page 33).
4. Select [**Save and continue**] after each step up until the step **Configure grid management service**.
5. Make the settings as described in the following.

Setting the connected line conductors

- In the tab **Feed-in management**, select the line conductor to which the inverter is connected from the drop-down list **Connected line conductors**.

Making settings for systems without a higher unit

1. Set **Feed-in management at the grid-connection point** to [**On**].
2. Enter the total PV array power in the field **Nominal PV system power**.
3. In the drop-down list **Operating mode of active power limitation at the grid-connection point**, select whether active power limitation is to be performed via a fixed specification in percent or in watts.
4. In the field **Set active power limit at the grid-connection point**, enter the value to which the active power at the grid-connection point is to be limited. The value must be set to **0** for zero export.

Making settings for systems with a higher unit

- Set **Feed-in management at the grid-connection point** to [**Off**].

Activating unbalanced load limitation

Depending on the country data set, unbalanced load limitation may have already been set. In this case, check the settings.

- If there are single-phase PV inverters in the system and unbalanced load limitation is requested, set **Unbalanced load limitation** to [**On**] and enter the maximum permissible unbalanced load in the field **Maximum unbalanced load**.

- If there are three-phase PV inverters in the system, set **Unbalanced load limitation** to [Off].

Setting PV inverter feed-in management

1. Activate the PV inverter user interface.
2. Log in as **Installer**.
3. Start the installation assistant on the PV inverter user interface.
4. Select [**Save and continue**] after each step up until the step **Configure grid management service**.
5. Ensure that the function **System control and power limitation** is set to [On].
6. In the drop-down list **Operating mode active power**, select the entry **Active power limitation P via system control**.
7. In the drop-down list **Operating mode for absent system control**, select the entry **Use fallback setting**.
8. In the field **Fallback active power P**, enter the same value as the one entered for the battery inverter. Where necessary, convert this value into a percentage. This ensures that in systems with Sunny Home Manager, the correct fallback value will be adopted in the event of a communication breakdown between Sunny Home Manager and inverter.
9. In the field **Timeout**, enter the time that the PV inverter is to wait before it limits its nominal power to the set fallback value.
10. If, in the event of a 0% or 0 W specification, the PV inverter is not permitted to feed small amounts of active power into the utility grid, select the entry **Yes** in the drop-down list **Grid disconnection at zero export**. This ensures that in the event of a 0% or 0 W specification, the inverter disconnects from the utility grid and does not feed in active power.

4.14 Configuring the Modbus Function

QUALIFIED PERSON

The Modbus interface is deactivated by default and the communication ports 502 set.

In order to access SMA inverters with SMA Modbus® or SunSpec® Modbus®, the Modbus interface must be activated. After activating the interface, the communication ports of both IP protocols can be changed. For information on commissioning and configuration of the Modbus interface, see the technical information "SMA and SunSpec Modbus® Interface" at www.SMA-Solar.com.

For information on which Modbus registers are supported, see the technical information "Modbus® parameters and measured values" at www.SMA-Solar.com.

i Data security during activated Modbus interface

If you activate the Modbus interface, there is a risk that unauthorized users may access and manipulate the data or devices in your PV system.

To ensure data security, take appropriate protective measures such as:

- Set up a firewall
- Close unnecessary network ports.
- Only enable remote access via VPN tunnel.
- Do not set up port forwarding at the communication port in use.
- In order to deactivate the Modbus interface, reset the inverter to the default settings or deactivate the activated parameter again.

i Deactivate the dynamic active power limitation for the PV inverters when controlled via Modbus

If the PV inverters and the battery inverter are controlled in a PV system via Modbus, the dynamic active power limitation of the PV inverters must be deactivated.

Procedure:

- Activate the Modbus interface and adjust the communication ports if necessary (see the technical information "SMA and SunSpec Modbus® Interface" at www.SMA-Solar.com).

4.15 Saving the Configuration in a File

Procedure:

1. Activate the user interface (see Section 4.1, page 25).
2. Log into the user interface (see Section 4.2, page 29).
3. Select the menu **Device Configuration**.
4. Select [**Settings**].
5. In the context menu, select [**Saving the configuration in a file**].
6. Follow the instructions in the dialog.

4.16 Adopting a Configuration from a File

⚠ QUALIFIED PERSON

To configure the inverter, you can adopt the configuration from a file. To be able to do this, you must first save the configuration of another inverter from the same type or device family in a file (see Section 4.15 "Saving the Configuration in a File", page 41). When saving, only the device parameters will be adopted, not any passwords.

Requirements:

- Changes to grid-relevant parameters must be approved by the responsible grid operator.
- The SMA Grid Guard code must be available (see "Application for SMA Grid Guard Code" at www.SMA-Solar.com).

Procedure:

1. Activate the user interface (see Section 4.1, page 25).
2. Log into the user interface as an **Installer**.
3. Select the menu **Device Configuration**.
4. Select [**Settings**].
5. In the context menu, select [**Adopting the configuration from a file**].
6. Follow the instructions in the dialog.

4.17 Updating the Firmware

QUALIFIED PERSON

If no automatic update is set for the inverter in the communication product (e.g. SMA Data Manager, Cluster Controller, Sunny Portal) or via the user interface of the inverter, you have the option of carrying out a manual firmware update.

Depending on the battery used, the firmware update of the inverter also updates the battery.

You have the following options to update the firmware:

- Update the firmware with the existing update file via the user interface of the inverter.
- Update the firmware with the existing update file via USB flash drive.
- Search and install the firmware via the user interface of the inverter.

Faulty firmware update due to disconnecting the inverter from the utility grid.

The inverter must be connected to the utility grid during the firmware update. The battery-backup and secure power-supply operation mode must be disabled. This ensures a proper firmware update.

- Do not disconnect the inverter from the utility grid during the firmware update.
- Do not enable secure power supply operation during the firmware update.
- Do not use the black-start button during the firmware update.

Update the firmware with the existing update file via the user interface of the inverter.

Requirements:

- An update file with the desired inverter firmware must be available. The update file is, for example, available for download on the product page of the inverter at www.SMA-Solar.com. To download the update file, it is necessary to enter the serial number of the inverter.

Procedure:

1. Activate the user interface (see Section 4.1, page 25).
2. Log into the user interface (see Section 4.2, page 29).
3. Select the menu **Device Configuration**.
4. In the inverter row, click on the gear icon and select **Update firmware**.
5. Select [**Browse**] and select the update file for the inverter.

6. Select **Update firmware**.
7. Follow the instructions in the dialog.

Update the firmware with the existing update file via USB flash drive.

Requirements:

- A USB flash drive with maximum 32 GB and file system FAT32 must be available.

Procedure:

1. Create an "UPDATE" folder on the USB stick.
2. Save the update file with the required firmware in the "UPDATE" folder on the USB flash drive. The update file is, for example, available for download on the product page of the inverter at www.SMA-Solar.com. Ensure that only the update file to which the inverter is to be updated must be stored on the USB flash drive.

3.

DANGER

Danger to life due to high voltages

- Disconnect the inverter from any voltage sources and open the enclosure lid of the Connection Unit (see the inverter installation manual).

4. Insert the USB flash drive in the USB port on the communication assembly.
5. Commission the inverter (see inverter installation manual).
 - During start-up phase of the inverter, the desired firmware is being installed.

6.

DANGER

Danger to life due to high voltages

- Disconnect the inverter from any voltage sources and open the enclosure lid of the Connection Unit (see the inverter installation manual).

7. Pull the USB flash drive out of the USB port.
8. Commission the inverter (see inverter installation manual).
9. Call up the user interface of the inverter and check the events to see whether a firmware update has been successfully completed.
10. If the firmware update has not been successfully completed, perform the firmware update again.

Search and install the firmware via the user interface of the inverter.

Requirements:

- The inverter must be connected to the Internet.

Procedure:

1. Open the user interface (see Section 4.1, page 25).
2. Log into the user interface (see Section 4.2, page 29).
3. Click on **[Edit parameters]**.

4. Go to **Device > Update**.
 5. Select the parameter **Check for update and install it** and set it to **Execute**.
 6. Click on [**Save all**].
- The firmware is updated in the background.

5 Cleaning the Inverter

NOTICE

Damage due to cleaning agents

The use of cleaning agents may cause damage to the product and its components.

- Clean the product and all its components only with a cloth moistened with clear water.
- Ensure that the inverter is free of dust, foliage and other dirt.

6 Troubleshooting

6.1 Forgotten Password

If you have forgotten the password for the inverter, you can unlock the inverter with a Personal Unlocking Key (PUK). For each inverter, there is one PUK for each user group (**User** and **Installer**).
Tip: With PV systems in Sunny Portal, you can also assign a new password via Sunny Portal for the user group **Installer**. The password for the user group **Installer** is the same as the system password in Sunny Portal.

Procedure:

1. Request PUK (application form available at www.SMA-Solar.com).
2. Activate the user interface (see Section 4.1, page 25).
3. Enter the PUK instead of the password into the field **Password**.
4. Select **Login**.
5. Call up the menu **Device Parameters**.
6. Select [**Edit parameters**].
7. In the parameter group **User Rights > Access Control** change the password of the desired user group.
8. Select [**Save all**] to save the changes.

i PV Systems in Sunny Portal

The password for the user group **Installer** is also the system password for the PV system in Sunny Portal. Changing the password of the user group **Installer** can lead to the inverter no longer being able to be reached by Sunny Portal.

- Assign the changed password of the user group **Installer** as the new system password in Sunny Portal (see the Sunny Portal user manual at www.SMA-Solar.com).

6.2 Event Messages

Event number	Message, cause and corrective measures
101	<p>⚠ QUALIFIED PERSON</p> <p>Grid fault</p> <p>The grid voltage or grid impedance at the connection point of the inverter is too high. The inverter has disconnected from the utility grid.</p> <p>Corrective measures:</p> <ul style="list-style-type: none"> • Ensure that the correct country data set has been configured. • Check whether the grid voltage at the connection point of the inverter is permanently in the permissible range. <p>If the grid voltage is outside the permissible range due to local grid conditions, contact the grid operator. The grid operator must agree with an adjustment of the voltage at the feed-in point or with a change of the monitored operating limits.</p> <p>If the grid voltage is permanently within the permissible range and this message is still displayed, contact Service.</p>
102	
103	
105	
202	<p>⚠ QUALIFIED PERSON</p> <p>Grid fault</p> <p>The utility grid has been disconnected, the AC cable is damaged or the grid voltage at the connection point of the inverter is too low. The inverter has disconnected from the utility grid.</p> <p>Corrective measures:</p> <ul style="list-style-type: none"> • Ensure that the circuit breaker is switched on. • Ensure that the AC cable is not damaged and that it is connected correctly. • Ensure that the country data set has been configured correctly. • Check whether the grid voltage at the connection point of the inverter is permanently in the permissible range. <p>If the grid voltage is outside the permissible range due to local grid conditions, contact the grid operator. The grid operator must agree with an adjustment of the voltage at the feed-in point or with a change of the monitored operating limits.</p> <p>If the grid voltage is permanently within the permissible range and this message is still displayed, contact Service.</p>
203	
205	
206	

Event number	Message, cause and corrective measures
301	<p data-bbox="311 188 582 220">⚠ QUALIFIED PERSON</p> <p data-bbox="288 236 392 260">Grid fault</p> <p data-bbox="288 272 994 384">The ten-minute average value of the grid voltage is no longer within the permissible range. The grid voltage or grid impedance at the connection point is too high. The inverter disconnects from the utility grid to maintain power quality.</p> <p data-bbox="288 395 504 419">Corrective measures:</p> <ul data-bbox="311 432 994 667" style="list-style-type: none"> <li data-bbox="311 432 994 603">• During the feed-in operation, check whether the grid voltage at the connection point of the inverter is permanently in the permissible range. If the grid voltage is outside the permissible range due to local grid conditions, contact the grid operator. The grid operator must agree with an adjustment of the voltage at the feed-in point or with a change of the monitored operating limits. <li data-bbox="311 616 994 667">• If the grid voltage is permanently within the permissible range and this message is still displayed, contact the Service.
302	<p data-bbox="288 683 616 707">Active power limited AC voltage</p> <p data-bbox="288 719 974 770">The inverter has reduced its power due to a too-high grid voltage to ensure grid stability.</p> <p data-bbox="288 783 504 807">Corrective measures:</p> <ul data-bbox="311 820 1005 957" style="list-style-type: none"> <li data-bbox="311 820 1005 957">• If possible, check the grid voltage and observe how often fluctuations occur. If fluctuations occur frequently and this message is displayed often, contact the grid operator and request approval to change the operating parameters of the inverter. If the grid operator gives his approval, discuss any changes to the operating parameters with the Service.
401 404	<p data-bbox="311 973 582 1005">⚠ QUALIFIED PERSON</p> <p data-bbox="288 1021 392 1045">Grid fault</p> <p data-bbox="288 1058 1005 1109">The inverter has disconnected from the utility grid. A stand-alone grid or a very large change in the power frequency was detected.</p> <p data-bbox="288 1121 504 1145">Corrective measures:</p> <ul data-bbox="311 1158 1005 1182" style="list-style-type: none"> <li data-bbox="311 1158 1005 1182">• Check the grid connection for significant short-term frequency fluctuations.

Event number	Message, cause and corrective measures
501	<p data-bbox="311 183 599 220">⚠ QUALIFIED PERSON</p> <p data-bbox="288 231 392 263">Grid fault</p> <p data-bbox="288 271 991 327">The power frequency is not within the permissible range. The inverter has disconnected from the utility grid.</p> <p data-bbox="288 335 509 359">Corrective measures:</p> <ul data-bbox="308 367 996 582" style="list-style-type: none"> <li data-bbox="308 367 907 422">• If possible, check the power frequency and observe how often fluctuations occur. If fluctuations occur frequently and this message is displayed often, contact the grid operator and request approval to change the operating parameters of the inverter. If the grid operator gives his approval, discuss any changes to the operating parameters with the Service.
507	<p data-bbox="288 590 649 622">Active power limited AC frequency</p> <p data-bbox="288 630 985 686">The inverter has reduced its power due to a too-high power frequency to ensure grid stability.</p> <p data-bbox="288 694 509 718">Corrective measures:</p> <ul data-bbox="308 726 1002 901" style="list-style-type: none"> <li data-bbox="308 726 1002 901">• If possible, check the power frequency and observe how often fluctuations occur. If fluctuations occur frequently and this message is displayed often, contact the grid operator and request approval to change the operating parameters of the inverter. If the grid operator gives his approval, discuss any changes to the operating parameters with the Service.
601	<p data-bbox="311 909 599 946">⚠ QUALIFIED PERSON</p> <p data-bbox="288 957 392 989">Grid fault</p> <p data-bbox="288 997 980 1053">The inverter has detected an excessively high proportion of direct current in the grid current.</p> <p data-bbox="288 1061 509 1085">Corrective measures:</p> <ul data-bbox="308 1093 968 1187" style="list-style-type: none"> <li data-bbox="308 1093 739 1125">• Check the grid connection for direct current. <li data-bbox="308 1125 968 1187">• If this message is displayed frequently, contact the grid operator and check whether the monitoring threshold on the inverter can be raised.

Event number	Message, cause and corrective measures
701	<p data-bbox="311 183 599 215">⚠ QUALIFIED PERSON</p> <p data-bbox="288 231 677 263">Freq. not permitted > Check parameter</p> <p data-bbox="288 271 991 327">The power frequency is not within the permissible range. The inverter has disconnected from the utility grid.</p> <p data-bbox="288 335 509 359">Corrective measures:</p> <ul data-bbox="311 367 996 574" style="list-style-type: none"> <li data-bbox="311 367 907 422">• If possible, check the power frequency and observe how often fluctuations occur. If fluctuations occur frequently and this message is displayed often, contact the grid operator and request approval to change the operating parameters of the inverter. <li data-bbox="311 518 935 574">• If the grid operator gives his approval, discuss any changes to the operating parameters with the Service.
901	<p data-bbox="311 590 599 622">⚠ QUALIFIED PERSON</p> <p data-bbox="288 638 666 670">PE conn. missing > Check connection</p> <p data-bbox="288 678 767 710">The grounding conductor is not correctly connected.</p> <p data-bbox="288 718 509 742">Corrective measures:</p> <ul data-bbox="311 750 879 774" style="list-style-type: none"> <li data-bbox="311 750 879 774">• Ensure that the grounding conductor is correctly connected.
1001	<p data-bbox="311 790 599 821">⚠ QUALIFIED PERSON</p> <p data-bbox="288 837 638 869">L/N swapped > Check connection</p> <p data-bbox="288 877 649 901">The connection of L and N is swapped.</p> <p data-bbox="288 909 509 933">Corrective measures:</p> <ul data-bbox="311 941 968 965" style="list-style-type: none"> <li data-bbox="311 941 968 965">• Ensure that L and N are correctly connected (see installation manual).
1101	<p data-bbox="311 989 599 1021">⚠ QUALIFIED PERSON</p> <p data-bbox="288 1037 565 1069">2nd phase connected to N</p> <p data-bbox="288 1077 688 1101">A second line conductor is connected to N.</p> <p data-bbox="288 1109 509 1133">Corrective measures:</p> <ul data-bbox="311 1141 890 1165" style="list-style-type: none"> <li data-bbox="311 1141 890 1165">• Connect the neutral conductor to N (see installation manual).
1302	<p data-bbox="311 1189 599 1220">⚠ QUALIFIED PERSON</p> <p data-bbox="288 1236 744 1268">Phase(s) or neutral conductor not connected</p> <p data-bbox="288 1276 487 1300">L or N not connected.</p> <p data-bbox="288 1308 509 1332">Corrective measures:</p> <ul data-bbox="311 1340 1002 1460" style="list-style-type: none"> <li data-bbox="311 1340 890 1364">• Ensure that L and N are connected (see installation manual). <li data-bbox="311 1372 1002 1428">• Ensure that the AC conductors are not damaged and correctly connected (see installation manual). <li data-bbox="311 1436 744 1460">• Ensure that the circuit breaker is switched on.

Event number	Message, cause and corrective measures
1501	<p data-bbox="311 183 599 220">⚠ QUALIFIED PERSON</p> <p data-bbox="288 231 532 263">Reconnection fault grid</p> <p data-bbox="288 271 991 359">The changed country data set or the value of a parameter you have set does not correspond to the local requirements. The inverter cannot connect to the utility grid.</p> <p data-bbox="288 367 509 391">Corrective measures:</p> <ul data-bbox="311 399 1002 454" style="list-style-type: none"> • Ensure that the country data set has been configured correctly. To do this, select the parameter Set country standard and check the value.
3301 3302 3303	<p data-bbox="311 462 599 499">⚠ QUALIFIED PERSON</p> <p data-bbox="288 510 492 542">Unstable operation</p> <p data-bbox="288 550 1002 614">There is not enough power at the DC input of the inverter for stable operation. The inverter cannot connect to the utility grid.</p> <p data-bbox="288 622 509 646">Corrective measures:</p> <ul data-bbox="311 654 856 678" style="list-style-type: none"> • Ensure that the correct battery type has been configured.
3401 3402 3407	<p data-bbox="311 686 599 722">⚠ QUALIFIED PERSON</p> <p data-bbox="288 734 700 766">DC overvoltage > Disconnect generator</p> <p data-bbox="288 774 823 805">Overvoltage at the DC input. This can destroy the inverter.</p> <p data-bbox="288 813 509 837">Corrective measures:</p> <ul data-bbox="311 845 980 1061" style="list-style-type: none"> • Immediately disconnect the inverter from all voltage sources. • Check whether the DC voltage is below the maximum input voltage of the inverter. If the DC voltage is below the maximum DC voltage of the inverter, reconnect the DC connectors to the inverter. • If the DC voltage is above the maximum DC voltage of the inverter, ensure that the correct battery has been selected. • If this message is repeated frequently, contact the Service.
3501	<p data-bbox="311 1077 599 1114">⚠ QUALIFIED PERSON</p> <p data-bbox="288 1125 660 1157">Insulation failure > Check generator</p> <p data-bbox="288 1165 800 1197">The inverter has detected a ground fault on the DC side.</p> <p data-bbox="288 1204 509 1228">Corrective measures:</p> <ul data-bbox="311 1236 812 1260" style="list-style-type: none"> • Check the battery and DC cabling for ground faults.

Event number	Message, cause and corrective measures
3601	<p data-bbox="311 188 596 220">⚠ QUALIFIED PERSON</p> <p data-bbox="288 236 695 268">High discharge curr. > Check generator</p> <p data-bbox="288 272 949 328">The leakage current of the inverter and the battery is too high. There is a ground fault, a residual current or a malfunction.</p> <p data-bbox="288 336 986 419">The inverter interrupts parallel grid operation immediately after exceeding a threshold. When the fault is eliminated, the inverter automatically reconnects to the utility grid.</p> <p data-bbox="288 427 508 451">Corrective measures:</p> <ul data-bbox="311 459 813 491" style="list-style-type: none"> • Check the battery and DC cabling for ground faults.
3701	<p data-bbox="311 502 596 534">⚠ QUALIFIED PERSON</p> <p data-bbox="288 550 680 582">Resid.curr.too.high > Check generator</p> <p data-bbox="288 587 986 643">The inverter detected a residual current due to brief grounding of the battery or the DC cabling.</p> <p data-bbox="288 651 508 675">Corrective measures:</p> <ul data-bbox="311 683 813 715" style="list-style-type: none"> • Check the battery and DC cabling for ground faults.
3801 3802 3805	<p data-bbox="311 730 596 762">⚠ QUALIFIED PERSON</p> <p data-bbox="288 778 642 810">DC overcurrent > Check generator</p> <p data-bbox="288 815 981 839">Overcurrent at the DC input. The inverter briefly interrupts feed-in operation.</p> <p data-bbox="288 847 508 871">Corrective measures:</p> <ul data-bbox="311 879 986 935" style="list-style-type: none"> • If this message is displayed frequently, ensure that the battery has been correctly connected and that the correct battery has been selected.
3901	<p data-bbox="311 959 596 991">⚠ QUALIFIED PERSON</p> <p data-bbox="288 1007 482 1038">DC power too low</p> <p data-bbox="288 1043 508 1067">Corrective measures:</p> <ul data-bbox="311 1075 997 1195" style="list-style-type: none"> • Check whether a new firmware version is available for the inverter and the battery. If a newer version is available, perform the firmware update. • If no new firmware version is available, check for other events. If there are other events, carry out the corrective measures for the other events.

Event number	Message, cause and corrective measures
3902	<p data-bbox="308 183 593 215">⚠ QUALIFIED PERSON</p> <p data-bbox="285 231 565 263">Generator voltage too low</p> <p data-bbox="285 271 509 295">Corrective measures:</p> <ul data-bbox="308 303 1002 446" style="list-style-type: none"> <li data-bbox="308 303 1002 359">• Check whether a new firmware version is available for the inverter and the battery. If a newer version is available, perform the firmware update. <li data-bbox="308 367 1002 446">• If a new firmware version is not available, check whether there are other event messages. If there are further event messages, perform the corrective measures of the further messages.
6001	<p data-bbox="308 470 593 502">⚠ QUALIFIED PERSON</p> <p data-bbox="285 518 509 550">System data restored</p> <p data-bbox="285 558 509 582">Corrective measures:</p> <ul data-bbox="308 590 834 614" style="list-style-type: none"> <li data-bbox="308 590 834 614">• If this message is displayed again, contact the Service.
6002	<p data-bbox="308 630 593 662">⚠ QUALIFIED PERSON</p> <p data-bbox="285 678 520 710">System data defective</p> <p data-bbox="285 718 509 742">Corrective measures:</p> <ul data-bbox="308 750 834 774" style="list-style-type: none"> <li data-bbox="308 750 834 774">• If this message is displayed again, contact the Service.
6003	<p data-bbox="308 790 593 821">⚠ QUALIFIED PERSON</p> <p data-bbox="285 837 621 869">System data access not possible</p> <p data-bbox="285 877 509 901">Corrective measures:</p> <ul data-bbox="308 909 834 933" style="list-style-type: none"> <li data-bbox="308 909 834 933">• If this message is displayed again, contact the Service.
6004	<p data-bbox="308 949 593 981">⚠ QUALIFIED PERSON</p> <p data-bbox="285 997 532 1029">Main memory defective</p> <p data-bbox="285 1037 509 1061">Corrective measures:</p> <ul data-bbox="308 1069 834 1093" style="list-style-type: none"> <li data-bbox="308 1069 834 1093">• If this message is displayed again, contact the Service.
6005	<p data-bbox="308 1109 593 1141">⚠ QUALIFIED PERSON</p> <p data-bbox="285 1157 532 1189">Code memory defective</p> <p data-bbox="285 1197 509 1220">Corrective measures:</p> <ul data-bbox="308 1228 834 1252" style="list-style-type: none"> <li data-bbox="308 1228 834 1252">• If this message is displayed again, contact the Service.
6006	<p data-bbox="308 1268 593 1300">⚠ QUALIFIED PERSON</p> <p data-bbox="285 1316 453 1348">CPU self-test HP</p> <p data-bbox="285 1356 509 1380">Corrective measures:</p> <ul data-bbox="308 1388 834 1412" style="list-style-type: none"> <li data-bbox="308 1388 834 1412">• If this message is displayed again, contact the Service.

Event number	Message, cause and corrective measures
6009	<p>Data inconsistency</p> <p>Corrective measures:</p> <ul style="list-style-type: none"> • If this message is displayed again, contact the Service.
6101	<p>⚠ QUALIFIED PERSON</p> <p>24 h watchdog test</p> <p>Corrective measures:</p> <ul style="list-style-type: none"> • If this message is displayed again, contact the Service.
6105	<p>⚠ QUALIFIED PERSON</p> <p>Execution (Operation)</p> <p>Processor defective.</p> <p>Corrective measures:</p> <ul style="list-style-type: none"> • Contact Service.
6107	<p>⚠ QUALIFIED PERSON</p> <p>Execution (State machine)</p> <p>Processor defective.</p> <p>Corrective measures:</p> <ul style="list-style-type: none"> • Contact Service.
6109	<p>⚠ QUALIFIED PERSON</p> <p>General BSP fault</p> <p>Processor defective.</p> <p>Corrective measures:</p> <ul style="list-style-type: none"> • Contact Service.
6111	<p>⚠ QUALIFIED PERSON</p> <p>Execution (SharedMemory)</p> <p>Processor defective.</p> <p>Corrective measures:</p> <ul style="list-style-type: none"> • Contact Service.
6112	<p>⚠ QUALIFIED PERSON</p> <p>Execution (Watchdog)</p> <p>Processor defective.</p> <p>Corrective measures:</p> <ul style="list-style-type: none"> • Contact Service.

Event number	Message, cause and corrective measures
6121	<p data-bbox="291 183 593 223">⚠ QUALIFIED PERSON</p> <p data-bbox="291 231 448 263">Watchdog DSP</p> <p data-bbox="291 271 470 295">Processor defective.</p> <p data-bbox="291 303 504 327">Corrective measures:</p> <ul data-bbox="308 335 481 367" style="list-style-type: none"><li data-bbox="308 335 481 367">• Contact Service.
6155	<p data-bbox="291 383 593 422">⚠ QUALIFIED PERSON</p> <p data-bbox="291 430 470 462">Version test failed</p> <p data-bbox="291 470 470 494">Processor defective.</p> <p data-bbox="291 502 504 526">Corrective measures:</p> <ul data-bbox="308 534 481 566" style="list-style-type: none"><li data-bbox="308 534 481 566">• Contact Service.
6202	<p data-bbox="291 574 593 614">⚠ QUALIFIED PERSON</p> <p data-bbox="291 622 470 654">DI converter fault</p> <p data-bbox="291 662 470 686">Measurement error.</p> <p data-bbox="291 694 504 718">Corrective measures:</p> <ul data-bbox="308 726 481 758" style="list-style-type: none"><li data-bbox="308 726 481 758">• Contact Service.
6301	<p data-bbox="291 766 593 805">⚠ QUALIFIED PERSON</p> <p data-bbox="291 813 548 845">Offset grid current sensor</p> <p data-bbox="291 853 470 877">Measurement error.</p> <p data-bbox="291 885 504 909">Corrective measures:</p> <ul data-bbox="308 917 481 949" style="list-style-type: none"><li data-bbox="308 917 481 949">• Contact Service.
6304	<p data-bbox="291 957 593 997">⚠ QUALIFIED PERSON</p> <p data-bbox="291 1005 627 1037">Grid voltage measurement offset</p> <p data-bbox="291 1045 470 1069">Measurement error.</p> <p data-bbox="291 1077 504 1101">Corrective measures:</p> <ul data-bbox="308 1109 481 1141" style="list-style-type: none"><li data-bbox="308 1109 481 1141">• Contact Service.
6305	<p data-bbox="291 1149 593 1189">⚠ QUALIFIED PERSON</p> <p data-bbox="291 1197 660 1228">Deviation grid voltage measurement</p> <p data-bbox="291 1236 470 1260">Measurement error.</p> <p data-bbox="291 1268 504 1292">Corrective measures:</p> <ul data-bbox="308 1300 481 1332" style="list-style-type: none"><li data-bbox="308 1300 481 1332">• Contact Service.

Event number	Message, cause and corrective measures
6306	<p>⚠ QUALIFIED PERSON</p> <p>DC voltage measurement deviation Measurement error.</p> <p>Corrective measures:</p> <ul style="list-style-type: none"> • Contact Service.
6401	<p>⚠ QUALIFIED PERSON</p> <p>Sensor system insulation resistance Measurement error.</p> <p>Corrective measures:</p> <ul style="list-style-type: none"> • Contact Service.
6403	<p>⚠ QUALIFIED PERSON</p> <p>Overvoltage grid (HW)</p> <p>Corrective measures:</p> <ul style="list-style-type: none"> • If there are several inverters in the system, check whether they also display this event message. If all inverters display this event message, a grid error is present. • If there is only one inverter, check for a grid error. • If there is no grid error and this message is displayed again, contact the Service.
6404	<p>⚠ QUALIFIED PERSON</p> <p>Overvoltage grid (HW)</p> <p>Corrective measures:</p> <ul style="list-style-type: none"> • Check whether there is a new firmware version available for the inverter. If a newer version is available, perform the firmware update. • If no new firmware version is available, contact Service.
6405	<p>⚠ QUALIFIED PERSON</p> <p>Overvoltage intermediate circuit (HW)</p> <p>Corrective measures:</p> <ul style="list-style-type: none"> • Check whether there is a new firmware version available for the inverter. If a newer version is available, perform the firmware update. • If no new firmware version is available, contact Service.

Event number	Message, cause and corrective measures
6406	<p data-bbox="311 188 595 220">⚠ QUALIFIED PERSON</p> <p data-bbox="288 236 557 263">Overcurrent input A (HW)</p> <p data-bbox="288 272 508 296">Corrective measures:</p> <ul data-bbox="311 308 999 526" style="list-style-type: none"> • Check whether a new firmware version is available for the inverter and the battery. If a newer version is available, perform the firmware update. • If no new firmware version is available, check for other events. If there are other events, carry out the corrective measures for the other events. • Check the battery for any faults. • Ensure that there is not a short circuit present at the DC connection. • If this message is displayed again, contact the Service.
6407	<p data-bbox="311 547 595 579">⚠ QUALIFIED PERSON</p> <p data-bbox="288 595 557 622">Overcurrent input B (HW)</p> <p data-bbox="288 632 508 655">Corrective measures:</p> <ul data-bbox="311 667 999 885" style="list-style-type: none"> • Check whether a new firmware version is available for the inverter and the battery. If a newer version is available, perform the firmware update. • If no new firmware version is available, check for other events. If there are other events, carry out the corrective measures for the other events. • Check the battery for any faults. • Ensure that there is not a short circuit present at the DC connection. • If this message is displayed again, contact the Service.
6408	<p data-bbox="311 903 595 935">⚠ QUALIFIED PERSON</p> <p data-bbox="288 951 454 978">UCE monitoring</p> <p data-bbox="288 987 508 1011">Corrective measures:</p> <ul data-bbox="311 1023 833 1050" style="list-style-type: none"> • If this message is displayed again, contact the Service.
6409	<p data-bbox="311 1067 595 1099">⚠ QUALIFIED PERSON</p> <p data-bbox="288 1115 483 1142">Bridge short-circuit</p> <p data-bbox="288 1152 508 1176">Corrective measures:</p> <ul data-bbox="311 1187 833 1214" style="list-style-type: none"> • If this message is displayed again, contact the Service.
6410	<p data-bbox="311 1232 595 1264">⚠ QUALIFIED PERSON</p> <p data-bbox="288 1279 669 1307">On-board supply system disturbance</p> <p data-bbox="288 1316 508 1340">Corrective measures:</p> <ul data-bbox="311 1351 833 1378" style="list-style-type: none"> • If this message is displayed again, contact the Service.

Event number	Message, cause and corrective measures
6411	<p data-bbox="311 188 595 220">⚠ QUALIFIED PERSON</p> <p data-bbox="288 236 405 260">Power unit</p> <p data-bbox="288 272 508 296">Corrective measures:</p> <ul data-bbox="311 308 833 331" style="list-style-type: none"> <li data-bbox="311 308 833 331">• If this message is displayed again, contact the Service.
6412	<p data-bbox="311 347 595 379">⚠ QUALIFIED PERSON</p> <p data-bbox="288 395 555 419">Overcurrent input C (HW)</p> <p data-bbox="288 432 508 456">Corrective measures:</p> <ul data-bbox="311 467 999 686" style="list-style-type: none"> <li data-bbox="311 467 999 523">• Check whether a new firmware version is available for the inverter and the battery. If a newer version is available, perform the firmware update. <li data-bbox="311 531 999 587">• If no new firmware version is available, check for other events. If there are other events, carry out the corrective measures for the other events. <li data-bbox="311 595 629 619">• Check the battery for any faults. <li data-bbox="311 627 945 651">• Ensure that there is not a short circuit present at the DC connection. <li data-bbox="311 659 833 686">• If this message is displayed again, contact the Service.
6415	<p data-bbox="311 707 595 738">⚠ QUALIFIED PERSON</p> <p data-bbox="288 754 521 778">Reference voltage test</p> <p data-bbox="288 791 508 815">Corrective measures:</p> <ul data-bbox="311 826 833 850" style="list-style-type: none"> <li data-bbox="311 826 833 850">• If this message is displayed again, contact the Service.
6416	<p data-bbox="311 866 595 898">⚠ QUALIFIED PERSON</p> <p data-bbox="288 914 577 938">External watchdog (enable)</p> <p data-bbox="288 951 508 975">Corrective measures:</p> <ul data-bbox="311 986 833 1010" style="list-style-type: none"> <li data-bbox="311 986 833 1010">• If this message is displayed again, contact the Service.
6462	<p data-bbox="311 1026 595 1058">⚠ QUALIFIED PERSON</p> <p data-bbox="288 1074 557 1098">Overcurrent battery (HW)</p> <p data-bbox="288 1110 508 1134">Corrective measures:</p> <ul data-bbox="311 1145 999 1265" style="list-style-type: none"> <li data-bbox="311 1145 999 1201">• Check whether a new firmware version is available for the inverter and the battery. If a newer version is available, perform the firmware update. <li data-bbox="311 1209 999 1265">• If no new firmware version is available and this message is displayed again, contact the Service.
6499	<p data-bbox="311 1281 595 1313">⚠ QUALIFIED PERSON</p> <p data-bbox="288 1329 725 1353">Precharging overload protection triggered</p> <p data-bbox="288 1366 508 1390">Corrective measures:</p> <ul data-bbox="311 1401 833 1425" style="list-style-type: none"> <li data-bbox="311 1401 833 1425">• If this message is displayed again, contact the Service.

Event number	Message, cause and corrective measures
6501	<p data-bbox="311 183 593 215">⚠ QUALIFIED PERSON</p> <p data-bbox="288 231 554 263">Overtemperature interior</p> <p data-bbox="288 271 509 295">Corrective measures:</p> <ul data-bbox="311 303 963 454" style="list-style-type: none"> • Check whether the airflow is free of dirt. • Ensure that the ambient temperature does not exceed the maximum permissible temperatures. • If the maximum permissible temperatures are met at all times and this message is displayed again, contact the Service.
6502	<p data-bbox="311 470 593 502">⚠ QUALIFIED PERSON</p> <p data-bbox="288 518 588 550">Overtemperature power unit</p> <p data-bbox="288 558 509 582">Corrective measures:</p> <ul data-bbox="311 590 963 742" style="list-style-type: none"> • Check whether the airflow is free of dirt. • Ensure that the ambient temperature does not exceed the maximum permissible temperatures. • If the maximum permissible temperatures are met at all times and this message is displayed again, contact the Service.
6509	<p data-bbox="311 758 593 790">⚠ QUALIFIED PERSON</p> <p data-bbox="288 805 638 837">Overtemperature boost converter</p> <p data-bbox="288 845 509 869">Corrective measures:</p> <ul data-bbox="311 877 963 1029" style="list-style-type: none"> • Check whether the airflow is free of dirt. • Ensure that the ambient temperature does not exceed the maximum permissible temperatures. • If the maximum permissible temperatures are met at all times and this message is displayed again, contact the Service.
6512	<p data-bbox="288 1045 756 1077">Minimum operating temperature not reached</p> <p data-bbox="288 1085 946 1133">The inverter will only recommence grid feed-in once the temperature has reached at least -25°C.</p>
6603	<p data-bbox="311 1149 593 1181">⚠ QUALIFIED PERSON</p> <p data-bbox="288 1197 520 1228">Overcurrent grid (SW)</p> <p data-bbox="288 1236 509 1260">Corrective measures:</p> <ul data-bbox="311 1268 991 1452" style="list-style-type: none"> • If there are several inverters in the system, check whether they also display this event message. If all inverters display this event message, a grid error is present. • If there is only one inverter, check for a grid error. • If there is no grid error and this message is displayed again, contact the Service.

Event number	Message, cause and corrective measures
6604	<p data-bbox="314 188 591 220">⚠ QUALIFIED PERSON</p> <p data-bbox="292 236 680 261">Overvoltage intermediate circuit (SW)</p> <p data-bbox="292 272 508 298">Corrective measures:</p> <ul data-bbox="311 308 999 459" style="list-style-type: none"> <li data-bbox="311 308 999 363">• Check whether there is a new firmware version available for the inverter. If a newer version is available, perform the firmware update. <li data-bbox="311 371 844 397">• If no new firmware version is available, contact Service. <li data-bbox="311 405 953 459">• Check whether there was a DC overvoltage. If DC overvoltage was present, contact the Service.
6607	<p data-bbox="314 481 591 513">⚠ QUALIFIED PERSON</p> <p data-bbox="292 529 654 555">Charge battery overcurr. (SW limit)</p> <p data-bbox="292 566 508 592">Corrective measures:</p> <ul data-bbox="311 601 999 715" style="list-style-type: none"> <li data-bbox="311 601 999 657">• Check whether a new firmware version is available for the inverter and the battery. If a newer version is available, perform the firmware update. <li data-bbox="311 665 967 715">• If no new firmware version is available and this message is displayed again, contact the Service.
6608	<p data-bbox="314 737 591 769">⚠ QUALIFIED PERSON</p> <p data-bbox="292 785 589 810">Disch. battery overcurr. (SW)</p> <p data-bbox="292 821 508 847">Corrective measures:</p> <ul data-bbox="311 857 999 970" style="list-style-type: none"> <li data-bbox="311 857 999 912">• Check whether a new firmware version is available for the inverter and the battery. If a newer version is available, perform the firmware update. <li data-bbox="311 920 967 970">• If no new firmware version is available and this message is displayed again, contact the Service.
6609	<p data-bbox="314 992 591 1024">⚠ QUALIFIED PERSON</p> <p data-bbox="292 1040 617 1066">Battery undervoltage (SW limit)</p> <p data-bbox="292 1077 508 1102">Corrective measures:</p> <ul data-bbox="311 1112 999 1224" style="list-style-type: none"> <li data-bbox="311 1112 999 1168">• Check whether a new firmware version is available for the inverter and the battery. If a newer version is available, perform the firmware update. <li data-bbox="311 1176 967 1224">• If no new firmware version is available and this message is displayed again, contact the Service.

Event number	Message, cause and corrective measures
6610	<p data-bbox="302 183 593 215">⚠ QUALIFIED PERSON</p> <p data-bbox="302 231 593 263">Battery overvoltage (SW limit)</p> <p data-bbox="302 271 504 295">Corrective measures:</p> <ul data-bbox="302 303 996 422" style="list-style-type: none"> <li data-bbox="302 303 996 359">• Check whether a new firmware version is available for the inverter and the battery. If a newer version is available, perform the firmware update. <li data-bbox="302 367 996 422">• If no new firmware version is available and this message is displayed again, contact the Service.
6701	<p data-bbox="302 438 593 470">⚠ QUALIFIED PERSON</p> <p data-bbox="302 486 481 518">Program Sequence</p> <p data-bbox="302 526 504 550">Corrective measures:</p> <ul data-bbox="302 558 996 678" style="list-style-type: none"> <li data-bbox="302 558 996 614">• Check whether a new firmware version is available for the inverter and the battery. If a newer version is available, perform the firmware update. <li data-bbox="302 622 996 678">• If no new firmware version is available and this message is displayed again, contact the Service.
6702	<p data-bbox="302 694 593 726">⚠ QUALIFIED PERSON</p> <p data-bbox="302 742 448 774">No system data</p> <p data-bbox="302 782 504 805">Corrective measures:</p> <ul data-bbox="302 813 996 933" style="list-style-type: none"> <li data-bbox="302 813 996 869">• Check whether a new firmware version is available for the inverter and the battery. If a newer version is available, perform the firmware update. <li data-bbox="302 877 996 933">• If no new firmware version is available and this message is displayed again, contact the Service.
6801	<p data-bbox="302 949 593 981">⚠ QUALIFIED PERSON</p> <p data-bbox="302 997 560 1029">Offset DC current sensor A</p> <p data-bbox="302 1037 504 1061">Corrective measures:</p> <ul data-bbox="302 1069 828 1093" style="list-style-type: none"> <li data-bbox="302 1069 828 1093">• If this message is displayed again, contact the Service.
6802	<p data-bbox="302 1109 593 1141">⚠ QUALIFIED PERSON</p> <p data-bbox="302 1157 604 1189">DC converter string A defective</p> <p data-bbox="302 1197 504 1220">Corrective measures:</p> <ul data-bbox="302 1228 828 1252" style="list-style-type: none"> <li data-bbox="302 1228 828 1252">• If this message is displayed again, contact the Service.
6901	<p data-bbox="302 1268 593 1300">⚠ QUALIFIED PERSON</p> <p data-bbox="302 1316 560 1348">Offset DC current sensor B</p> <p data-bbox="302 1356 504 1380">Corrective measures:</p> <ul data-bbox="302 1388 828 1412" style="list-style-type: none"> <li data-bbox="302 1388 828 1412">• If this message is displayed again, contact the Service.

Event number	Message, cause and corrective measures
6902	<p>⚠ QUALIFIED PERSON</p> <p>DC converter string B defective</p> <p>Corrective measures:</p> <ul style="list-style-type: none"> • If this message is displayed again, contact the Service.
7001	<p>⚠ QUALIFIED PERSON</p> <p>Fault sensor interior temperature</p> <p>Measurement error.</p> <p>Corrective measures:</p> <ul style="list-style-type: none"> • Contact Service.
7002	<p>⚠ QUALIFIED PERSON</p> <p>Fault sensor power unit temperature</p> <p>Measurement error.</p> <p>Corrective measures:</p> <ul style="list-style-type: none"> • Contact Service.
7106	<p>Update file defect.</p> <p>The update file is defective. The update failed. The inverter continues to feed in.</p>
7110	<p>No update file found</p> <p>No new update file was found on the SD memory card. The update failed. The inverter continues to feed in.</p>
7112	<p>Update file successfully copied</p>
7113	<p>The memory card is full or write-protected</p>
7201	<p>Data storage defective</p> <p>Corrective measures:</p> <ul style="list-style-type: none"> • If this message is displayed again, contact the Service.
7202	<p>Long term data defective</p> <p>Corrective measures:</p> <ul style="list-style-type: none"> • If this message is displayed again, contact the Service.
7303	<p>⚠ QUALIFIED PERSON</p> <p>Update main CPU failed</p> <p>The cause must be determined by the Service.</p> <p>Corrective measures:</p> <ul style="list-style-type: none"> • Contact Service.

Event number	Message, cause and corrective measures
7320	The device with serial number [xx] was successfully updated to firmware version [xx].
7324	<p data-bbox="308 255 593 295">⚠ QUALIFIED PERSON</p> <p data-bbox="285 303 565 335">Wait for update conditions</p> <p data-bbox="285 343 991 399">The testing of the update conditions was not successful. The firmware update package is not suitable for this inverter.</p> <p data-bbox="285 406 509 430">Corrective measures:</p> <ul data-bbox="308 438 896 534" style="list-style-type: none"> • Retry update. • Ensure that the selected update file is suitable for this inverter. • If this message is displayed again, contact the Service.
7330	<p data-bbox="308 550 593 590">⚠ QUALIFIED PERSON</p> <p data-bbox="285 598 498 630">Condition test failed</p> <p data-bbox="285 638 509 662">Corrective measures:</p> <ul data-bbox="308 670 896 766" style="list-style-type: none"> • Retry update. • Ensure that the selected update file is suitable for this inverter. • If this message is displayed again, contact the Service.
7331	<p data-bbox="285 782 543 813">Update transport started</p> <p data-bbox="285 821 543 845">Update file is being copied.</p>
7332	<p data-bbox="285 861 576 893">Update transport successful</p> <p data-bbox="285 901 918 925">Update file was copied successfully to the inverter's internal memory.</p>
7333	<p data-bbox="308 933 593 973">⚠ QUALIFIED PERSON</p> <p data-bbox="285 981 532 1013">Update transport failed</p> <p data-bbox="285 1021 996 1101">Update file could not be copied to the inverter's internal memory. In the event of connection with the inverter via WLAN, a poor connection quality can be the cause.</p> <p data-bbox="285 1109 509 1133">Corrective measures:</p> <ul data-bbox="308 1141 834 1204" style="list-style-type: none"> • Retry update. • If this message is displayed again, contact the Service.
7337	<p data-bbox="308 1220 593 1260">⚠ QUALIFIED PERSON</p> <p data-bbox="285 1268 868 1300">Battery management system update unsuccessful ([d0])</p> <p data-bbox="285 1308 509 1332">Corrective measures:</p> <ul data-bbox="308 1340 896 1436" style="list-style-type: none"> • Retry update. • Ensure that the selected update file is suitable for this inverter. • If this message is displayed again, contact the Service.

Event number	Message, cause and corrective measures
7340	Update communication failed
7347	<p>⚠ QUALIFIED PERSON</p> <p>Incompatible file The configuration file is not suitable for this inverter.</p> <p>Corrective measures:</p> <ul style="list-style-type: none"> • Ensure that the selected configuration file is suitable for this inverter. • Retry import.
7348	<p>⚠ QUALIFIED PERSON</p> <p>Incorrect file format The configuration file is not of the required format or is damaged.</p> <p>Corrective measures:</p> <ul style="list-style-type: none"> • Ensure that the selected configuration file is of the required format and is not damaged. • Retry import.
7349	<p>Incorrect login rights for configuration file The configuration file cannot be loaded.</p> <p>Corrective measures:</p> <ul style="list-style-type: none"> • Ensure you are logged on in the correct user level to load the configuration file.
7350	<p>Transfer of a configuration file has started The configuration file is being transferred.</p>
7351	<p>Update WLAN The inverter is updating the WLAN module.</p>
7352	<p>⚠ QUALIFIED PERSON</p> <p>Update of WLAN not successful The update of the WLAN module failed.</p> <p>Corrective measures:</p> <ul style="list-style-type: none"> • Retry update. • If this message is displayed again, contact the Service.
7353	<p>Update time zone database The inverter is updating the time zone database.</p>

Event number	Message, cause and corrective measures
7354	<p data-bbox="291 183 593 215">⚠ QUALIFIED PERSON</p> <p data-bbox="291 231 750 263">Update of time zone database not successful</p> <p data-bbox="291 271 705 295">The update of the time zone database failed.</p> <p data-bbox="291 303 504 327">Corrective measures:</p> <ul data-bbox="308 335 828 399" style="list-style-type: none"> <li data-bbox="308 335 459 359">• Retry update. <li data-bbox="308 367 828 399">• If this message is displayed again, contact the Service.
7355	<p data-bbox="291 414 448 438">Update WebUI</p> <p data-bbox="291 446 739 470">The inverter is updating the inverter user interface.</p>
7356	<p data-bbox="291 494 593 526">⚠ QUALIFIED PERSON</p> <p data-bbox="291 542 649 566">Update of the WebUI not successful</p> <p data-bbox="291 574 716 598">The update of the inverter user interface failed.</p> <p data-bbox="291 606 504 630">Corrective measures:</p> <ul data-bbox="308 638 828 702" style="list-style-type: none"> <li data-bbox="308 638 459 662">• Retry update. <li data-bbox="308 670 828 702">• If this message is displayed again, contact the Service.
7357	<p data-bbox="291 718 414 742">Update BIM</p> <p data-bbox="291 750 985 805">The Battery Interface Module on the communication assembly has been successfully updated.</p>
7358	<p data-bbox="291 821 593 853">⚠ QUALIFIED PERSON</p> <p data-bbox="291 869 481 893">Update BIM failed</p> <p data-bbox="291 901 974 957">The Battery Interface Module on the communication assembly has not been updated successfully.</p> <p data-bbox="291 965 504 989">Corrective measures:</p> <ul data-bbox="308 997 828 1061" style="list-style-type: none"> <li data-bbox="308 997 459 1021">• Retry update. <li data-bbox="308 1029 828 1061">• If this message is displayed again, contact the Service.
7359	<p data-bbox="291 1085 414 1109">Update BUC</p> <p data-bbox="291 1117 952 1173">The SMA Backup Unit Controller that is installed in the automatic transfer switch has been updated successfully.</p>

Event number	Message, cause and corrective measures
7360	<p data-bbox="311 185 596 220">⚠ QUALIFIED PERSON</p> <p data-bbox="288 236 484 263">Update BUC failed</p> <p data-bbox="288 272 508 300">Corrective measures:</p> <ul data-bbox="311 308 1012 520" style="list-style-type: none"> <li data-bbox="311 308 1012 363">• Ensure that the communication between SMA Backup Unit Controller and the inverter functions perfectly. <li data-bbox="311 371 1012 451">• Ensure that the cable requirements of the communication cable for the communication between the SMA Backup Unit Controller and the inverter have been met. <li data-bbox="311 459 460 486">• Retry update. <li data-bbox="311 494 833 520">• If this message is displayed again, contact the Service.
7619	<p data-bbox="311 536 596 571">⚠ QUALIFIED PERSON</p> <p data-bbox="288 587 1003 614">Communication fault with meter unit > Check communication to meter</p> <p data-bbox="288 624 841 651">The inverter is not receiving any data from the energy meter.</p> <p data-bbox="288 659 508 686">Corrective measures:</p> <ul data-bbox="311 694 1012 746" style="list-style-type: none"> <li data-bbox="311 694 1012 746">• Ensure that the energy meter is correctly integrated into the same network as the inverter (see energy meter manual).
7623	<p data-bbox="311 759 596 794">⚠ QUALIFIED PERSON</p> <p data-bbox="288 810 745 837">Communication to backup module disrupted</p> <p data-bbox="288 847 1003 903">The communication between the inverter and the SMA Backup Unit Controller in the automatic transfer switch is disrupted.</p> <p data-bbox="288 911 508 938">Corrective measures:</p> <ul data-bbox="311 946 1012 1184" style="list-style-type: none"> <li data-bbox="311 946 1012 1026">• Ensure that the cable requirements of the communication cable for the communication between the SMA Backup Unit Controller and the inverter have been met. <li data-bbox="311 1034 460 1061">• Retry update. <li data-bbox="311 1069 609 1096">• Carry out communication test. <li data-bbox="311 1104 997 1184">• If the communication test was successful, contact the manufacturer of the automatic transfer switch. If the communication test failed, contact the Service.

Event number	Message, cause and corrective measures
7624	<p data-bbox="311 183 599 215">⚠ QUALIFIED PERSON</p> <p data-bbox="288 231 840 263">Communication to battery interface module disrupted</p> <p data-bbox="288 271 991 327">The communication between the inverter and the battery interface module on the communication assembly is disrupted.</p> <p data-bbox="288 335 509 359">Corrective measures:</p> <ul data-bbox="311 367 1002 454" style="list-style-type: none"> • Ensure that the ribbon cable is in perfect condition and securely in place. • If the ribbon cable is in perfect condition and firmly plugged in the jack, contact the Service.
7701	<p data-bbox="311 470 599 502">⚠ QUALIFIED PERSON</p> <p data-bbox="288 518 543 550">Grid disconnection point</p> <p data-bbox="288 558 610 582">Grid relay of the inverter defective.</p> <p data-bbox="288 590 509 614">Corrective measures:</p> <ul data-bbox="311 622 487 646" style="list-style-type: none"> • Contact Service.
7702	<p data-bbox="288 662 420 694">Relay defect</p> <p data-bbox="288 702 610 726">Grid relay of the inverter defective.</p> <p data-bbox="288 734 509 758">Corrective measures:</p> <ul data-bbox="311 766 487 790" style="list-style-type: none"> • Contact Service.
7703	<p data-bbox="311 813 599 845">⚠ QUALIFIED PERSON</p> <p data-bbox="288 861 431 893">24h relay test</p> <p data-bbox="288 901 442 925">Relay test failed.</p> <p data-bbox="288 933 509 957">Corrective measures:</p> <ul data-bbox="311 965 834 989" style="list-style-type: none"> • If this message is displayed again, contact the Service.
8003	<p data-bbox="311 1013 599 1045">⚠ QUALIFIED PERSON</p> <p data-bbox="288 1061 599 1093">Active power limited derating</p> <p data-bbox="288 1101 1002 1157">The inverter has reduced its power output for more than ten minutes due to excessive temperature.</p> <p data-bbox="288 1165 509 1189">Corrective measures:</p> <ul data-bbox="311 1197 980 1372" style="list-style-type: none"> • Clean the cooling fins on the rear of the enclosure and the air ducts on the top using a soft brush. • Ensure that the inverter has sufficient ventilation. • Ensure that the ambient temperature +45°C (113°F) has not been exceeded. • Ensure that the inverter is not exposed to direct solar irradiation.

Event number	Message, cause and corrective measures
8101	<p data-bbox="311 183 595 220">⚠ QUALIFIED PERSON</p> <p data-bbox="288 231 535 263">Main memory defective</p> <p data-bbox="288 268 509 295">Corrective measures:</p> <ul data-bbox="311 303 834 331" style="list-style-type: none"> <li data-bbox="311 303 834 331">• If this message is displayed again, contact the Service.
8102	<p data-bbox="311 343 595 379">⚠ QUALIFIED PERSON</p> <p data-bbox="288 391 535 422">Code memory defective</p> <p data-bbox="288 427 509 454">Corrective measures:</p> <ul data-bbox="311 462 834 491" style="list-style-type: none"> <li data-bbox="311 462 834 491">• If this message is displayed again, contact the Service.
8103	<p data-bbox="311 502 595 539">⚠ QUALIFIED PERSON</p> <p data-bbox="288 550 453 582">CPU self-test HP</p> <p data-bbox="288 587 456 614">The self-test failed.</p> <p data-bbox="288 619 509 646">Corrective measures:</p> <ul data-bbox="311 654 834 683" style="list-style-type: none"> <li data-bbox="311 654 834 683">• If this message is displayed again, contact the Service.
8104	<p data-bbox="311 702 595 738">⚠ QUALIFIED PERSON</p> <p data-bbox="288 750 532 782">internal communication</p> <p data-bbox="288 786 509 813">Corrective measures:</p> <ul data-bbox="311 821 834 850" style="list-style-type: none"> <li data-bbox="311 821 834 850">• If this message is displayed again, contact the Service.
8501	<p data-bbox="311 861 595 898">⚠ QUALIFIED PERSON</p> <p data-bbox="288 909 557 941">DC current sensor C offset</p> <p data-bbox="288 946 509 973">Corrective measures:</p> <ul data-bbox="311 981 834 1010" style="list-style-type: none"> <li data-bbox="311 981 834 1010">• If this message is displayed again, contact the Service.
8502	<p data-bbox="311 1021 595 1058">⚠ QUALIFIED PERSON</p> <p data-bbox="288 1069 607 1101">DC converter string C defective</p> <p data-bbox="288 1106 509 1133">Corrective measures:</p> <ul data-bbox="311 1141 834 1169" style="list-style-type: none"> <li data-bbox="311 1141 834 1169">• If this message is displayed again, contact the Service.
8708	<p data-bbox="311 1181 595 1217">⚠ QUALIFIED PERSON</p> <p data-bbox="288 1228 834 1260">Timeout in communication for active power limitation</p> <p data-bbox="288 1265 1002 1356">Communication to the system control absent. Depending on the fall-back setting, either the last received values will be retained or the active power will be limited to the set percentage value of the inverter nominal power.</p> <p data-bbox="288 1361 509 1388">Corrective measures:</p> <ul data-bbox="311 1396 957 1457" style="list-style-type: none"> <li data-bbox="311 1396 957 1457">• Ensure that the connection to the system control is intact and that no cables are damaged or that no plugs have been pulled.

Event number	Message, cause and corrective measures
8709	<p data-bbox="311 183 593 215">⚠ QUALIFIED PERSON</p> <p data-bbox="288 231 812 263">Timeout in communication for reactive power spec.</p> <p data-bbox="288 271 1002 359">Communication to the system control absent. Depending on the fall-back setting, either the last received values will be retained or the active power will be limited to the set percentage value of the inverter nominal power.</p> <p data-bbox="288 363 509 391">Corrective measures:</p> <ul data-bbox="311 399 957 454" style="list-style-type: none"> • Ensure that the connection to the system control is intact and that no cables are damaged or that no plugs have been pulled.
8710	<p data-bbox="311 470 593 502">⚠ QUALIFIED PERSON</p> <p data-bbox="288 518 728 550">Timeout in communication for cos-Phi spec.</p> <p data-bbox="288 558 1002 646">Communication to the system control absent. Depending on the fall-back setting, either the last received values will be retained or the active power will be limited to the set percentage value of the inverter nominal power.</p> <p data-bbox="288 651 509 678">Corrective measures:</p> <ul data-bbox="311 686 957 742" style="list-style-type: none"> • Ensure that the connection to the system control is intact and that no cables are damaged or that no plugs have been pulled.
9002	<p data-bbox="311 750 593 782">⚠ QUALIFIED PERSON</p> <p data-bbox="288 798 599 829">SMA Grid Guard code invalid</p> <p data-bbox="288 837 1002 893">The SMA Grid Guard code entered is incorrect. The operating parameters are still protected and cannot be changed.</p> <p data-bbox="288 901 509 928">Corrective measures:</p> <ul data-bbox="311 933 711 965" style="list-style-type: none"> • Enter the correct SMA Grid Guard code.
9003	<p data-bbox="288 973 532 1005">Grid parameter locked</p> <p data-bbox="288 1013 1002 1093">Changes to the grid parameters are now blocked. In order to be able to make changes to the grid parameters, from now on you must log in using the SMA Grid Guard code.</p>
9005	<p data-bbox="311 1117 593 1149">⚠ QUALIFIED PERSON</p> <p data-bbox="288 1165 924 1197">Changing of grid parameters not possible > Ensure DC supply</p> <p data-bbox="288 1204 666 1228">This error can have the following causes:</p> <ul data-bbox="311 1236 957 1292" style="list-style-type: none"> • The parameters to be changed are protected. • The DC voltage at the DC input is not sufficient to run the main CPU. <p data-bbox="288 1300 509 1327">Corrective measures:</p> <ul data-bbox="311 1332 935 1428" style="list-style-type: none"> • Enter the SMA Grid Guard code. • Ensure that at least the DC start voltage is available (green LED is flashing, pulsing or glowing).

Event number	Message, cause and corrective measures
9007	<p data-bbox="311 188 596 220">⚠ QUALIFIED PERSON</p> <p data-bbox="292 236 432 260">Abort self-test</p> <p data-bbox="292 272 544 296">The self-test was terminated.</p> <p data-bbox="292 309 507 333">Corrective measures:</p> <ul data-bbox="311 341 507 365" style="list-style-type: none"> <li data-bbox="311 341 507 365">• Restart the self-test.
9202	<p data-bbox="311 387 596 419">⚠ QUALIFIED PERSON</p> <p data-bbox="292 435 497 459">SPS AC overvoltage</p> <p data-bbox="292 472 1003 520">An AC source has been connected to the outlet for secure power supply operation.</p> <p data-bbox="292 533 507 557">Corrective measures:</p> <ul data-bbox="311 564 919 620" style="list-style-type: none"> <li data-bbox="311 564 919 620">• Check the connection at the SPS slots, and make any necessary corrections.
9203	<p data-bbox="311 643 596 675">⚠ QUALIFIED PERSON</p> <p data-bbox="292 691 656 715">Short circuit in the SPS power outlet</p> <p data-bbox="292 727 1003 807">The maximum initial load has been overshoot or the appliance's initial current is above the maximum permissible load current of the terminal for secure power supply operation for more than 5 s.</p> <p data-bbox="292 820 507 844">Corrective measures:</p> <ul data-bbox="311 852 947 908" style="list-style-type: none"> <li data-bbox="311 852 947 876">• Reduce the load at the terminal for secure power supply operation. <li data-bbox="311 884 880 908">• If necessary, select an appliance with a lower initial current.
9204	<p data-bbox="311 930 596 962">⚠ QUALIFIED PERSON</p> <p data-bbox="292 978 592 1002">AC overvoltage backup (fast)</p> <p data-bbox="292 1015 1009 1062">Voltage in the battery-backup grid too high or step changes in load too high in the battery-backup grid.</p> <p data-bbox="292 1075 507 1099">Corrective measures:</p> <ul data-bbox="311 1107 997 1206" style="list-style-type: none"> <li data-bbox="311 1107 997 1131">• Check whether there is a new firmware version available for the inverter. <li data-bbox="311 1139 885 1163">• If a newer version is available, perform the firmware update. <li data-bbox="311 1171 841 1206">• If no new firmware version is available, contact Service.

Event number	Message, cause and corrective measures
9205	<p>⚠ QUALIFIED PERSON</p> <p>AC overvoltage backup (slow) Voltage in the battery-backup grid too high or step changes in load too high in the battery-backup grid.</p> <p>Corrective measures:</p> <ul style="list-style-type: none"> • Check whether there is a new firmware version available for the inverter. • If a newer version is available, perform the firmware update. • If no new firmware version is available, contact Service.
9206	<p>⚠ QUALIFIED PERSON</p> <p>Short circuit in backup Loads in the battery-backup grid too high.</p> <p>Corrective measures:</p> <ul style="list-style-type: none"> • Reduce loads. • Contact Service.
9207	<p>⚠ QUALIFIED PERSON</p> <p>Backup module bimetal switch Automatic transfer switching device error.</p> <p>Corrective measures:</p> <ul style="list-style-type: none"> • Contact the manufacturer of the automatic transfer switching device.
9208	<p>⚠ QUALIFIED PERSON</p> <p>Backup module relay error [d0] Relay in automatic transfer switching device faulty.</p> <p>Corrective measures:</p> <ul style="list-style-type: none"> • Contact the manufacturer of the automatic transfer switching device.
9209	<p>⚠ QUALIFIED PERSON</p> <p>N-PE monitoring backup module</p> <p>Corrective measures:</p> <ul style="list-style-type: none"> • Contact the manufacturer of the automatic transfer switching device.
9211	<p>⚠ QUALIFIED PERSON</p> <p>Backup module overtemperature</p> <p>Corrective measures:</p> <ul style="list-style-type: none"> • Check the installation of the automatic transfer switching device. • Contact the manufacturer of the automatic transfer switching device.

Event number	Message, cause and corrective measures
9214	<p data-bbox="311 183 593 215">⚠ QUALIFIED PERSON</p> <p data-bbox="288 231 644 263">Black start battery voltage too low</p> <p data-bbox="288 271 1002 359">The service life of the backup battery has expired. The backup battery must be replaced when you want to use the black start for the battery-backup function or the secure power supply operation.</p> <p data-bbox="288 367 504 391">Corrective measures:</p> <ul data-bbox="311 399 817 454" style="list-style-type: none"> • Procure new backup battery and exchange batteries. • Contact Service.
9215	<p data-bbox="311 470 593 502">⚠ QUALIFIED PERSON</p> <p data-bbox="288 518 711 550">Battery interface module hardware error</p> <p data-bbox="288 558 666 582">The battery interface module is defective.</p> <p data-bbox="288 590 504 614">Corrective measures:</p> <ul data-bbox="311 622 487 646" style="list-style-type: none"> • Contact Service.
9216	<p data-bbox="311 670 593 702">⚠ QUALIFIED PERSON</p> <p data-bbox="288 718 532 750">Supply voltage too low</p> <p data-bbox="288 758 504 782">Corrective measures:</p> <ul data-bbox="311 790 968 877" style="list-style-type: none"> • Check whether the ribbon cable between the inverter and the battery interface module on the communication assembly is correctly inserted. • If this message is displayed again, contact the Service.
9217	<p data-bbox="311 893 593 925">⚠ QUALIFIED PERSON</p> <p data-bbox="288 941 1002 997">Output supply voltage of the battery interface module too low xx xx </p> <p data-bbox="288 1005 504 1029">Corrective measures:</p> <ul data-bbox="311 1037 968 1133" style="list-style-type: none"> • Check whether the plugs for connecting the battery and the automatic transfer switching device are correctly inserted. • If this message is displayed again, contact the Service.
9218	<p data-bbox="311 1149 593 1181">⚠ QUALIFIED PERSON</p> <p data-bbox="288 1197 946 1228">Battery interface module output communication error xx xx </p> <p data-bbox="288 1236 504 1260">Corrective measures:</p> <ul data-bbox="311 1268 968 1356" style="list-style-type: none"> • Check whether the plugs for connecting the battery and the automatic transfer switching device are correctly inserted. • Carry out communication test.

Event number	Message, cause and corrective measures
9219	<p>⚠ QUALIFIED PERSON</p> <p>Battery interface module output communication error xx xx </p> <p>Corrective measures:</p> <ul style="list-style-type: none"> • Ensure that only one node each is connected to the terminal for the communication cables of the battery and the automatic transfer switching device.
9220	<p>Battery interface module test mode xx , success rate: xx </p> <p>The communication test was successful.</p>
9221	<p>⚠ QUALIFIED PERSON</p> <p>Limitation of the switching frequency of the input relay for current limitation</p> <p>There are too many faulty control commands by the system control.</p> <p>Corrective measures:</p> <ul style="list-style-type: none"> • Check system control.
9223	<p>Backup operation</p> <p>The battery-backup function is enabled.</p>
9301	<p>New battery detected</p>
9303	<p>⚠ QUALIFIED PERSON</p> <p>The service life of the battery is expiring</p> <p>The battery can fail anytime.</p> <p>Corrective measures:</p> <ul style="list-style-type: none"> • Procure new battery and exchange batteries.
9304	<p>⚠ QUALIFIED PERSON</p> <p>Battery connection fault</p> <p>Corrective measures:</p> <ul style="list-style-type: none"> • Check terminal for the data cable of the battery. • Carry out communication test.
9305	<p>⚠ QUALIFIED PERSON</p> <p>Unauthorized battery system</p> <p>Corrective measures:</p> <ul style="list-style-type: none"> • Check whether there is a new firmware version available for the battery. If a newer version is available, perform the firmware update. • If this message is displayed again, contact the Service (see Section 8, page 87).

Event number	Message, cause and corrective measures
9306	<p data-bbox="314 188 583 220">⚠ QUALIFIED PERSON</p> <p data-bbox="292 236 580 263">Deviation in battery voltage</p> <p data-bbox="292 272 508 300">Corrective measures:</p> <ul data-bbox="311 308 972 400" style="list-style-type: none"> <li data-bbox="311 308 575 335">• Check the DC connection. <li data-bbox="311 341 972 400">• If this message is displayed again, contact the Service (see Section 8, page 87).
9307	<p data-bbox="314 414 583 446">⚠ QUALIFIED PERSON</p> <p data-bbox="292 462 542 489">Battery system defective</p> <p data-bbox="292 499 508 526">Corrective measures:</p> <ul data-bbox="311 534 645 560" style="list-style-type: none"> <li data-bbox="311 534 645 560">• Contact the battery manufacturer.
9308	<p data-bbox="314 574 583 606">⚠ QUALIFIED PERSON</p> <p data-bbox="292 622 667 649">Communication error battery system</p> <p data-bbox="292 659 508 686">Corrective measures:</p> <ul data-bbox="311 694 978 786" style="list-style-type: none"> <li data-bbox="311 694 978 786">• Carry out communication test. If the test was successful, contact the battery manufacturer. If the test was not successful, contact the Service (see Section 8, page 87).
9311	<p data-bbox="314 798 583 829">⚠ QUALIFIED PERSON</p> <p data-bbox="292 845 591 873">Battery cell overvoltage fault</p> <p data-bbox="292 882 508 909">Corrective measures:</p> <ul data-bbox="311 917 645 943" style="list-style-type: none"> <li data-bbox="311 917 645 943">• Contact the battery manufacturer.
9312	<p data-bbox="314 957 583 989">⚠ QUALIFIED PERSON</p> <p data-bbox="292 1005 604 1032">Battery cell undervoltage fault</p> <p data-bbox="292 1042 508 1069">Corrective measures:</p> <ul data-bbox="311 1077 645 1102" style="list-style-type: none"> <li data-bbox="311 1077 645 1102">• Contact the battery manufacturer.
9313	<p data-bbox="314 1117 583 1149">⚠ QUALIFIED PERSON</p> <p data-bbox="292 1165 598 1192">Battery low temperature fault</p> <p data-bbox="292 1201 508 1228">Corrective measures:</p> <ul data-bbox="311 1236 645 1262" style="list-style-type: none"> <li data-bbox="311 1236 645 1262">• Contact the battery manufacturer.
9314	<p data-bbox="314 1276 583 1308">⚠ QUALIFIED PERSON</p> <p data-bbox="292 1324 546 1351">Battery overtemperature</p> <p data-bbox="292 1361 508 1388">Corrective measures:</p> <ul data-bbox="311 1396 645 1422" style="list-style-type: none"> <li data-bbox="311 1396 645 1422">• Contact the battery manufacturer.

Event number	Message, cause and corrective measures
9315	<p>⚠ QUALIFIED PERSON</p> <p>Battery imbalancing fault</p> <p>Corrective measures:</p> <ul style="list-style-type: none"> • Contact the battery manufacturer.
9316	<p>⚠ QUALIFIED PERSON</p> <p>Internal battery hardware fault</p> <p>Corrective measures:</p> <ul style="list-style-type: none"> • Contact the battery manufacturer.
9334	<p>Battery charging test</p> <p>The battery test for charging the battery is carried out.</p>
9335	<p>Discharge battery test</p> <p>The battery test for discharging the battery is carried out.</p>
9336	<p>⚠ QUALIFIED PERSON</p> <p>Start conditions for battery test not fulfilled</p> <p>The state of charge of the battery is too low or too high for carrying out the test.</p> <p>Corrective measures:</p> <ul style="list-style-type: none"> • Perform the test that has not been performed yet.
9337	<p>Charge battery test successful</p>
9338	<p>Battery discharging test successful</p>
9339	<p>⚠ QUALIFIED PERSON</p> <p>Battery charging test failed</p> <p>Corrective measures:</p> <ul style="list-style-type: none"> • Check the installation of the battery. • Perform the test that has not been performed yet.
9340	<p>⚠ QUALIFIED PERSON</p> <p>Battery discharging test failed</p> <p>Corrective measures:</p> <ul style="list-style-type: none"> • Check the installation of the battery. • Perform the test that has not been performed yet.

Event number	Message, cause and corrective measures
9345	<p>⚠ QUALIFIED PERSON</p> <p>Battery charging for start process too low</p> <p>Corrective measures:</p> <ul style="list-style-type: none"> • Contact the battery manufacturer.
9346	<p>⚠ QUALIFIED PERSON</p> <p>Battery not configured</p> <p>Corrective measures:</p> <ul style="list-style-type: none"> • Start the installation assistant on the inverter user interface and perform the battery configuration.
9347	<p>⚠ QUALIFIED PERSON</p> <p>Battery b0 reports event: 0x x5 x4 , 0x x7 x6 , 0x x9 x8 , 0x xB xA </p> <p>Corrective measures:</p> <ul style="list-style-type: none"> • Contact the battery manufacturer.
9351	<p>⚠ QUALIFIED PERSON</p> <p>Incorrect switch position for the battery disconnection point</p> <p>Corrective measures:</p> <ul style="list-style-type: none"> • Contact the battery manufacturer.
9352	<p>⚠ QUALIFIED PERSON</p> <p>Battery system short circuit</p> <p>Corrective measures:</p> <ul style="list-style-type: none"> • Contact the battery manufacturer.
9353	<p>⚠ QUALIFIED PERSON</p> <p>Battery system thermal management defective</p> <p>Corrective measures:</p> <ul style="list-style-type: none"> • Check whether there is a new firmware version available for the battery. If a newer version is available, perform the firmware update. • If this message is displayed again, contact the battery manufacturer.

Event number	Message, cause and corrective measures
9354	<p>⚠ QUALIFIED PERSON</p> <p>Battery system heating procedure unsuccessful</p> <p>Corrective measures:</p> <ul style="list-style-type: none"> • Check whether there is a new firmware version available for the battery. If a newer version is available, perform the firmware update. • If this message is displayed again, contact the battery manufacturer.
10100	Parameter [xxx] set successfully. xxxx to xxxx
10101	<p>Setting of parameter ln04 failed. xxxx to xxxx </p> <p>Corrective measures:</p> <ul style="list-style-type: none"> • Change parameter again and save change.
10102	Parameter [xxx] set successfully. xxx to xxx
10103	<p>Setting of parameter [xxxx] failed. xxx to xxx </p> <p>Corrective measures:</p> <ul style="list-style-type: none"> • Change parameter again and save change.
10104	Parameter [xxxx] set successfully
10105	<p>Setting of parameter xxxx failed.</p> <p>Corrective measures:</p> <ul style="list-style-type: none"> • Change parameter again and save change.
10108	Time adjusted / old time
10109	Time adjusted / new time
10110	<p>Time synchronization failed: [x]</p> <p>No time information could be called up from the set NTP server.</p> <p>Corrective measures:</p> <ul style="list-style-type: none"> • Ensure that the NTP server was configured correctly. • Ensure that the inverter is integrated into a local network with Internet connection.
10116	Setting of parameter [xxxx] failed. Conflict with parameter xxxx
10118	Parameter upload complete
10120	Currently permitted number of parameterizations exceeded
10224	Dynamic settings established

Event number	Message, cause and corrective measures
10248	<p data-bbox="292 185 501 212">[tn4]: network busy</p> <p data-bbox="292 220 1012 276">The network is busy. Data exchange between the devices is not at an optimum and is greatly delayed.</p> <p data-bbox="292 284 508 308">Corrective measures:</p> <ul data-bbox="311 320 865 411" style="list-style-type: none"> <li data-bbox="311 320 751 344">• Reduce the number of devices in the network. <li data-bbox="311 352 759 376">• If necessary, increase the data query intervals. <li data-bbox="311 384 865 411">• If necessary, reduce the number of devices in the network.
10249	<p data-bbox="292 427 583 459">⚠ QUALIFIED PERSON</p> <p data-bbox="292 480 572 507">[tn4]: network overloaded</p> <p data-bbox="292 515 1012 571">The network is busy. Data exchange between the devices is not at an optimum and is greatly delayed.</p> <p data-bbox="292 579 508 603">Corrective measures:</p> <ul data-bbox="311 616 865 707" style="list-style-type: none"> <li data-bbox="311 616 751 639">• Reduce the number of devices in the network. <li data-bbox="311 647 759 671">• If necessary, increase the data query intervals. <li data-bbox="311 679 865 707">• If necessary, reduce the number of devices in the network.
10250	<p data-bbox="292 722 583 754">⚠ QUALIFIED PERSON</p> <p data-bbox="292 775 723 802">[Interface]: package error rate [ok / high]</p> <p data-bbox="292 810 1012 890">The package error rate has changed. If the package error rate is high, the network is overloaded or the connection to the network switch or DHCP server (router) is disturbed.</p> <p data-bbox="292 898 837 930">Corrective measures if the package error rate is high:</p> <ul data-bbox="311 938 1012 1090" style="list-style-type: none"> <li data-bbox="311 938 1012 1018">• Ensure that with an Ethernet connection, the network cable and the network connector are not damaged and that the network connectors are correctly plugged. <li data-bbox="311 1026 759 1050">• If necessary, increase the data query intervals. <li data-bbox="311 1058 865 1090">• If necessary, reduce the number of devices in the network.
10251	<p data-bbox="292 1106 966 1161">[Interface]: communication status goes to [OK / Warning / Error / Not connected]</p> <p data-bbox="292 1169 1012 1224">The communication status to the network switch or DHCP server (router) has changed. An additional error message may be displayed.</p>

Event number	Message, cause and corrective measures
10252	<p data-bbox="311 188 595 220">⚠ QUALIFIED PERSON</p> <p data-bbox="288 236 669 263">[Interface]: communication disrupted</p> <p data-bbox="288 272 685 300">There is no valid signal on the network line.</p> <p data-bbox="288 309 508 336">Corrective measures:</p> <ul data-bbox="311 344 1012 491" style="list-style-type: none"> <li data-bbox="311 344 1012 427">• Ensure that with an Ethernet connection, the network cable and the network connector are not damaged and that the network connectors are correctly plugged. <li data-bbox="311 435 1012 491">• Ensure that the DHCP server (router) and any network switches are signaling correct operation.
10253	<p data-bbox="311 504 595 536">⚠ QUALIFIED PERSON</p> <p data-bbox="288 552 891 579">[Interface]: connection speed goes to [100 Mbit / 10 Mbit]</p> <p data-bbox="288 588 1003 671">The data transfer rate has changed. The cause for the status [10 Mbit] can be a defective plug, a defective cable or the pulling or plugging of the network connector.</p> <p data-bbox="288 681 752 708">Corrective measures if the status is [10 Mbit]:</p> <ul data-bbox="311 716 1012 863" style="list-style-type: none"> <li data-bbox="311 716 1012 799">• Ensure that with an Ethernet connection, the network cable and the network connector are not damaged and that the network connectors are correctly plugged. <li data-bbox="311 807 1012 863">• Ensure that the DHCP server (router) and any network switches are signaling correct operation.
10254	<p data-bbox="311 880 595 912">⚠ QUALIFIED PERSON</p> <p data-bbox="288 928 752 956">[Interface]: duplex mode goes to [Full / Half]</p> <p data-bbox="288 965 1003 1048">The duplex mode (data transfer mode) has changed. The cause for the status [Half] can be a defective plug, a defective cable or the pulling or plugging of the network connector.</p> <p data-bbox="288 1058 716 1085">Corrective measures if the status is [Half]:</p> <ul data-bbox="311 1093 1012 1240" style="list-style-type: none"> <li data-bbox="311 1093 1012 1176">• Ensure that with an Ethernet connection, the network cable and the network connector are not damaged and that the network connectors are correctly plugged. <li data-bbox="311 1184 1012 1240">• Ensure that the DHCP server (router) and any network switches are signaling correct operation.
10255	<p data-bbox="288 1257 595 1284">[Interface]: Network load OK</p> <p data-bbox="288 1294 900 1321">The network load has returned to a normal range after being busy.</p>

Event number	Message, cause and corrective measures
10282	<p>[User group]-Login via [protocol] locked</p> <p>After several incorrect login attempts, login has been blocked for a limited time. In this case, the User login will be blocked for 15 minutes, the Grid Guard login for 12 hours.</p> <p>Corrective measures:</p> <ul style="list-style-type: none"> • Wait until the given time has expired and then retry login.
10283	<p>WLAN module faulty</p> <p>The WLAN module integrated in the inverter is defective.</p> <p>Corrective measures:</p> <ul style="list-style-type: none"> • Contact Service.
10284	<p>⚠ QUALIFIED PERSON</p> <p>No WLAN connection possible</p> <p>The inverter does not currently have a WLAN connection to the selected network.</p> <p>Corrective measures:</p> <ul style="list-style-type: none"> • Ensure that the SSID, the WLAN password and the encryption method have been entered correctly. The encryption method is specified by your WLAN router or WLAN Access Point and can be changed there. • Ensure that the WLAN router or WLAN Access Point is in range and is signaling correct operation. • If this message is displayed often, improve the WLAN connection by using a WLAN repeater (e.g. SMA Antenna Extension Kit).
10285	<p>WLAN connection established</p> <p>Connection to the selected WLAN network has been established.</p>
10286	<p>⚠ QUALIFIED PERSON</p> <p>WLAN connection lost</p> <p>The inverter has lost WLAN connection to the selected network.</p> <p>Corrective measures:</p> <ul style="list-style-type: none"> • Ensure that the WLAN router or WLAN Access Point is still active. • Ensure that the WLAN router or WLAN Access Point is in range and is signaling correct operation. • If this message is displayed often, improve the WLAN connection by using a WLAN repeater (e.g. SMA Antenna Extension Kit).
10287	<p>WLAN module detected</p>
10339	<p>Webconnect enabled</p> <p>The inverter can communicate with Sunny Portal without an additional SMA communications product (e.g. Sunny Data Manager).</p>

Event number	Message, cause and corrective measures
10340	<p>Webconnect disabled</p> <p>The Webconnect function has been switched off. This means that the inverter can not communicate with Sunny Portal without an additional SMA communications product (e.g. Sunny Data Manager).</p> <ul style="list-style-type: none"> • If the inverter is to communicate with Sunny Portal without an additional SMA communication product, switch the Webconnect function on.
10341	<p>Webconnect error: no connection</p> <p>It is likely that there is an error in the network settings.</p> <p>Corrective measures:</p> <ul style="list-style-type: none"> • Check the network components (DLAN, WLAN Access Point etc.). • Ensure that the following ports are not blocked: <ul style="list-style-type: none"> - Registrar: ied.sma.de:9523 - Proxy: ied.sma.de:9523 - Stun: stun.sma.de:3478 - Domain: ied.sma.de (for SIP URI)
10343	<p>Webconnect error: Default gateway not configured</p> <p>It is likely that there is an error in the network settings.</p> <p>Corrective measures:</p> <ul style="list-style-type: none"> • Check the network components (DLAN, WLAN Access Point etc.). • Ensure that the following ports are not blocked: <ul style="list-style-type: none"> - Registrar: ied.sma.de:9523 - Proxy: ied.sma.de:9523 - Stun: stun.sma.de:3478 - Domain: ied.sma.de (for SIP URI)
10344	<p>Webconnect error: DNS server not configured</p> <p>It is likely that there is an error in the network settings.</p> <p>Corrective measures:</p> <ul style="list-style-type: none"> • Check the network components (DLAN, WLAN Access Point etc.). • Ensure that the following ports are not blocked: <ul style="list-style-type: none"> - Registrar: ied.sma.de:9523 - Proxy: ied.sma.de:9523 - Stun: stun.sma.de:3478 - Domain: ied.sma.de (for SIP URI)

Event number	Message, cause and corrective measures
10345	<p>No reply to DNS request</p> <p>It is likely that there is an error in the network settings.</p> <p>Corrective measures:</p> <ul style="list-style-type: none"> • Check the network components (DLAN, WLAN Access Point etc.). • Ensure that the following ports are not blocked: <ul style="list-style-type: none"> - Registrar: ied.sma.de:9523 - Proxy: ied.sma.de:9523 - Stun: stun.sma.de:3478 - Domain: ied.sma.de (for SIP URI)
10346	<p>SIP proxy DNS resolution failed</p> <p>It is likely that there is an error in the network settings.</p> <p>Corrective measures:</p> <ul style="list-style-type: none"> • Check the network components (DLAN, WLAN Access Point etc.). • Ensure that the following ports are not blocked: <ul style="list-style-type: none"> - Registrar: ied.sma.de:9523 - Proxy: ied.sma.de:9523 - Stun: stun.sma.de:3478 - Domain: ied.sma.de (for SIP URI)
10347	<p>Stun server DNS resolution failed</p> <p>It is likely that there is an error in the network settings.</p> <p>Corrective measures:</p> <ul style="list-style-type: none"> • Check the network components (DLAN, WLAN Access Point etc.). • Ensure that the following ports are not blocked: <ul style="list-style-type: none"> - Registrar: ied.sma.de:9523 - Proxy: ied.sma.de:9523 - Stun: stun.sma.de:3478 - Domain: ied.sma.de (for SIP URI)
10348	<p>Webconnect error: No reply to request to STUN server</p> <p>It is likely that there is an error in the network settings.</p> <p>Corrective measures:</p> <ul style="list-style-type: none"> • Check the network components (DLAN, WLAN Access Point etc.). • Ensure that the following ports are not blocked: <ul style="list-style-type: none"> - Registrar: ied.sma.de:9523 - Proxy: ied.sma.de:9523 - Stun: stun.sma.de:3478 - Domain: ied.sma.de (for SIP URI)

Event number	Message, cause and corrective measures
10349	<p>Webconnect error: No reply to SIP option packs</p> <p>It is likely that there is an error in the network settings or a Sunny Portal maintenance message is present.</p> <p>Corrective measures:</p> <ul style="list-style-type: none"> • If a Sunny Portal maintenance message is present, wait until the maintenance has been completed. • Check the network components (DLAN, WLAN Access Point etc.). • Ensure that the following ports are not blocked: <ul style="list-style-type: none"> - Registrar: ied.sma.de:9523 - Proxy: ied.sma.de:9523 - Stun: stun.sma.de:3478 - Domain: ied.sma.de (for SIP URI)
10350	<p>Webconnect error: Registration rejected by SIP registrar</p> <p>It is likely that there is an error in the network settings.</p> <p>Corrective measures:</p> <ul style="list-style-type: none"> • Check the network components (DLAN, WLAN Access Point etc.). • Ensure that the following ports are not blocked: <ul style="list-style-type: none"> - Registrar: ied.sma.de:9523 - Proxy: ied.sma.de:9523 - Stun: stun.sma.de:3478 - Domain: ied.sma.de (for SIP URI)
10351	<p>Unknown SIP registry</p> <p>It is likely that there is an error in the network settings.</p> <p>Corrective measures:</p> <ul style="list-style-type: none"> • Check the network components (DLAN, WLAN Access Point etc.). • Ensure that the following ports are not blocked: <ul style="list-style-type: none"> - Registrar: ied.sma.de:9523 - Proxy: ied.sma.de:9523 - Stun: stun.sma.de:3478 - Domain: ied.sma.de (for SIP URI)

Event number	Message, cause and corrective measures
10352	<p>Webconnect error: Faulty communication</p> <p>It is likely that there is an error in the network settings or a Sunny Portal maintenance message is present.</p> <p>Corrective measures:</p> <ul style="list-style-type: none"> • If a Sunny Portal maintenance message is present, wait until the maintenance has been completed. • Check the network components (DLAN, WLAN Access Point etc.). • Ensure that the following ports are not blocked: <ul style="list-style-type: none"> - Registrar: ied.sma.de:9523 - Proxy: ied.sma.de:9523 - Stun: stun.sma.de:3478 - Domain: ied.sma.de (for SIP URI)
10353	<p>Webconnect error: registration of the SIP registry has not responded</p> <p>It is likely that there is an error in the network settings or a Sunny Portal maintenance message is present.</p> <p>Corrective measures:</p> <ul style="list-style-type: none"> • If a Sunny Portal maintenance message is present, wait until the maintenance has been completed. • Check the network components (DLAN, WLAN Access Point etc.). • Ensure that the following ports are not blocked: <ul style="list-style-type: none"> - Registrar: ied.sma.de:9523 - Proxy: ied.sma.de:9523 - Stun: stun.sma.de:3478 - Domain: ied.sma.de (for SIP URI)
10420	Internal consumption control was started
10421	Internal consumption control was stopped
10513	NSS quick stop: [tn0] through [tn4] is executed
10517	Dynamic active power limitation started.
10518	Dynamic active power limitation terminated.
10520	Supplied power: [u0] W (permitted value: [u4] W)
10521	Active power was limited today for [u0] minutes.
10525	Inverter does not respond to active power limitation.
10528	Login for NSD function on device [s0] failed
27107	<p>Update file OK</p> <p>The update file is suitable for this inverter and its components and is fully available for the next update step.</p>

Event number	Message, cause and corrective measures
27108	Memory card is being read The storage medium is being read.
27109	No new update on the memory card A new update file was not found on the storage medium.
27301	Update communication The inverter is updating the communication component.
27302	Update main CPU The inverter is updating the inverter component.
27312	Update completed The inverter has successfully completed the update.
27329	Condition test successful
27331	Update transport started The inverter has successfully started the update.
27332	Update transport successful The update file has been successfully transferred to the communication component.
27336	Battery management system
29001	Inst. code valid The entered Grid Guard code is valid. Protected parameters have now been unlocked and you can adjust the parameters. The parameters will be automatically locked again after ten feed-in hours.
29004	Grid parameters unchanged Changing the grid parameters is not possible.
29006	Self-test
29016	Stand-alone operation
29252	SPS mode not available The battery's state of charge is insufficient to supply the loads in secure power supply operation.
29253	Input power for backup too low The battery's state of charge is insufficient to supply the loads in the battery-backup grid.
29254	Input power for SPS too low The battery's state of charge is insufficient to supply the loads in secure power supply operation.

7 Compliance Information

FCC Compliance

This device complies with Part 15 of the FCC Rules and with Industry Canada licence-exempt RSS standard(s).

Operation is subject to the following two conditions:

1. this device may not cause harmful interference, and
2. this device must accept any interference received, including interference that may cause undesired operation.

Le présent appareil est conforme aux CNR d'Industrie Canada applicables aux appareils radio exempts de licence.

L'exploitation est autorisée aux deux conditions suivantes :

1. l'appareil ne doit pas produire de brouillage, et
2. l'utilisateur de l'appareil doit accepter tout brouillage radioélectrique subi, même si le brouillage est susceptible d'en compromettre le fonctionnement.

NOTE: This equipment has been tested and found to comply with the limits for a Class B digital device, pursuant to Part 15 of the FCC Rules. These limits are designed to provide reasonable protection against harmful interference in a residential installation. This equipment generates, uses and can radiate radio frequency energy and, if not installed and used in accordance with the instructions, may cause harmful interference to radio communications. However, there is no guarantee that interference will not occur in a particular installation. If this equipment does cause harmful interference to radio or television reception, which can be determined by turning the equipment off and on, the user is encouraged to try to correct the interference by one or more of the following measures:

- Reorient or relocate the receiving antenna.
- Increase the separation between the equipment and receiver.
- Connect the equipment into an outlet on a circuit different from that to which the receiver is connected.
- Consult the dealer or an experienced radio/TV technician for help.

Changes or modifications made to this equipment not expressly approved by SMA Solar Technology AG may void the FCC authorization to operate this equipment.

8 Contact

If you have technical problems with our products, please contact the SMA Service Line. The following data is required in order to provide you with the necessary assistance:

- Battery inverter:
 - Device type
 - Serial number
 - Firmware version
 - Event message
 - Mounting location and mounting height
 - Optional equipment, e.g. communication products
 - Use the name of the system in Sunny Portal (if available)
 - Access data for Sunny Portal (if available)
 - Special country-specific settings (if available)
- Batteries:
 - Type
 - Firmware version
 - Type of automatic transfer switch (if available)

United States	SMA Solar Technology America LLC Rocklin, CA	Toll free for USA and US Territories +1 877-MY-SMATech (+1 877-697-6283) International: +1 916 625-0870
Canada	SMA Solar Technology Canada Inc. Mississauga	Toll free for Canada / Sans frais pour le Canada : +1 877-MY-SMATech (+1 877-697-6283)
México	SMA Solar Technology de México Mexico City	Internacional: +1 916 625-0870

