



Installation Manual - Quick Reference Guide

SMA FLEXIBLE STORAGE SYSTEM

Increased Self-Consumption with
SUNNY ISLAND 3.0M / 4.4M / 6.0H / 8.0H and SUNNY HOME MANAGER



Legal Provisions

The information contained in this document is the property of SMA Solar Technology AG. Publishing its content, either partially or in full, requires the written permission of SMA Solar Technology AG. Any internal company copying of the document for the purposes of evaluating the product or its correct implementation is allowed and does not require permission.

SMA Warranty

You can download the current warranty conditions from the Internet at www.SMA-Solar.com.

Trademarks

All trademarks are recognized, even if not explicitly identified as such. A lack of identification does not mean that a product or symbol is not trademarked.

The BLUETOOTH® word mark and logos are registered trademarks owned by Bluetooth SIG, Inc. and any use of these marks by SMA Solar Technology AG is under license.

Modbus® is a registered trademark of Schneider Electric and is licensed by the Modbus Organization, Inc.

QR Code is a registered trademark of DENSO WAVE INCORPORATED.

Phillips® and Pozidriv® are registered trademarks of Phillips Screw Company.

Torx® is a registered trademark of Acument Global Technologies, Inc.

SMA Solar Technology AG

Sonnenallee 1
34266 Niestetal
Germany

Tel. +49 561 9522-0
Fax +49 561 9522-100
www.SMA.de
E-mail: info@SMA.de

© 2004 to 2016 SMA Solar Technology AG. All rights reserved.

Table of Contents

1	Information on this Document	5
1.1	Validity	5
1.2	Content and Structure of this Document	5
1.3	Target Group	5
1.4	Additional Information	5
1.5	Symbols	6
1.6	Typographies	6
1.7	Nomenclature	6
2	Safety	7
2.1	Intended Use	7
2.2	Safety Information	8
3	Information and System Description	10
3.1	Requirements of the "VDE Forum Network Technology / Network Operations (FNN)"	10
3.2	Requirements of VDE Application Guide 2510-2	11
3.3	System Information	12
3.4	System Description	13
4	System With One Sunny Island	14
4.1	Circuitry Overview	14
4.2	Connecting the Sunny Island	15
5	System With Three Sunny Island Inverters	17
5.1	Circuitry Overview	17
5.2	Connecting the Master	18
5.3	Connecting Slave 1 and Slave 2	19
6	Connecting the Sunny Home Manager	21
7	Commissioning	22
7.1	Basic Configuration of the Sunny Island Inverter	22
7.2	Adjusting the Configuration of the Sunny Island Inverter	26
7.2.1	Countries in Which the Configuration Must Be Adjusted	26
7.2.2	Adjusting the Configuration for Denmark	26
7.2.3	Adjusting the Configuration for Austria	27
7.2.4	Adjusting the Configuration for Switzerland	27
7.3	Preparing BLUETOOTH Communication	28
7.4	Commissioning the SMA Flexible Storage System	28
8	Contact	31

1 Information on this Document

1.1 Validity

This document is valid for the SMA Flexible Storage System with the following SMA products:

- HM-BT-10.GR2 (Sunny Home Manager) from firmware version 1.04
- SI3.0M-11 (Sunny Island 3.0M) with firmware version 3.2
- SI4.4M-11 (Sunny Island 4.4M) with firmware version 3.2
- SI6.0H-11 (Sunny Island 6.0H) with firmware version 3.1
- SI8.0H-11 (Sunny Island 8.0H) with firmware version 3.1

1.2 Content and Structure of this Document

This document summarizes the specific information for the installation of an SMA Flexible Storage System. Circuitry overviews provide the basic principle of how an SMA Flexible Storage System is connected. The structure of the document specifies the chronological sequence for configuration and commissioning. This document does not replace the documentation of the individual products. You will find details and help in the event of difficulties in the documentation of the respective product.

1.3 Target Group

The activities described in this document must only be performed by qualified persons. Qualified persons must have the following skills:









- Training in how to deal with the dangers and risks associated with installing and using electrical devices and batteries
- Training in the installation and commissioning of electrical devices
- Knowledge of and adherence to the local standards and directives
- Knowledge of and compliance with this document and all safety information

1.4 Additional Information

Links to additional information can be found at www.SMA-Solar.com:

Document title	Document type
SMA Smart Home	Planning Guidelines
Sunny Explorer	User manual
SMA BLUETOOTH Wireless Technology	Technical description
SMA BLUETOOTH Wireless Technology in Practice	Technical Information

1.5 Symbols

Symbol	Explanation
	Indicates a hazardous situation which, if not avoided, will result in death or serious injury
	Indicates a hazardous situation which, if not avoided, can result in death or serious injury
	Indicates a hazardous situation which, if not avoided, can result in minor or moderate injury
	Indicates a situation which, if not avoided, can result in property damage
	Information that is important for a specific topic or goal, but is not safety-relevant
	Indicates a requirement for meeting a specific goal
	Desired result
	A problem that might occur

1.6 Typographies

Typography	Usage	Example
bold	<ul style="list-style-type: none"> • Display messages • Parameters • Terminals • Slots • Elements to be selected • Elements to be entered 	<ul style="list-style-type: none"> • Connect the grounding conductor to AC 2Gen/Grid. • Select the parameter 235.01 GnAutoEna and set to Off.
>	<ul style="list-style-type: none"> • Several elements that are to be selected 	<ul style="list-style-type: none"> • Select 600# Direct Access > Select Number.

1.7 Nomenclature

Complete designation	Designation in this document
SMA BLUETOOTH Wireless Technology	BLUETOOTH
Sunny Boy, Sunny Mini Central, Sunny Tripower	PV inverters
SMA radio-controlled socket with BLUETOOTH Wireless Technology	SMA radio-controlled socket
SMA Speedwire	Speedwire
SMA Speedwire data module for Sunny Island	Speedwire data module Sunny Island
SMA Speedwire/Webconnect Data Module	Speedwire data module
Gird-forming generators such as electric generators or utility grids	External Energy Sources
Sunny Explorer, Sunny Portal, Sunny Home Manager	Communication product

2 Safety

2.1 Intended Use

The SMA Flexible Storage System supports increased self-consumption through the following measures:

- Intermediate storage of excess PV energy with Sunny Island
- Load control and PV system monitoring with Sunny Home Manager

The SMA Flexible Storage System does not form a battery backup grid in the event of utility grid failure (for installation of a battery backup system, see Quick Reference Guide "SMA Flexible Storage System with Battery Backup Grid").

The SMA Flexible Storage System must only be used in those countries for which it is licensed or in those countries for which it is approved by SMA Solar Technology AG and the grid operator. The grid configuration must be a TN or TT system.

The SMA Flexible Storage System records the grid feed-in and purchased electricity with an SMA Energy Meter only. An SMA Energy Meter does not replace the energy meter of the electric utility company. The grid feed-in and the purchased electricity are transmitted to one Sunny Island via Speedwire. To enable this, the Sunny Island must be fitted with the Speedwire data module Sunny Island.

The Sunny Home Manager must not be installed in PV systems in which a SMA Cluster Controller is installed.

In the SMA Flexible Storage System, the Sunny Island uses lead-acid batteries or lithium-ion batteries for energy storage. A fuse switch-disconnector (e.g., BatFuse) must be installed between the battery and the Sunny Island. In systems with lead-acid batteries, you must ensure that the battery room is sufficiently ventilated (see battery manufacturer documentation). If lithium-ion batteries are connected, the battery management of the lithium-ion battery must be compatible with the Sunny Island (see the Planning Guidelines "SMA Smart Home" at www.SMA-Solar.com).

Three Sunny Island inverters can be connected to form a three-phase cluster. A cluster is connected in parallel on the DC side and a shared battery is connected. Only Sunny Island inverters of the same device type may be installed in a cluster. More than one cluster cannot be connected.

The SMA Flexible Storage System can be installed at altitudes of up to 2,000 m above Mean Sea Level.

The following products must not be connected in the SMA Flexible Storage System:

- Sunny Island Charger or other DC charge controllers
- DC loads

Use this system only in accordance with the information provided in the enclosed documentation and with the locally applicable standards and directives. Any other application may cause personal injury or property damage.

Alterations to the system, e.g. modifications or conversions, are only permitted with the express written permission of SMA Solar Technology AG. Unauthorized alterations will void guarantee and warranty claims and usually void the operating license. SMA Solar Technology AG shall not be held liable for any damage caused by such alterations.

Any use of the system other than that described in the Intended Use section does not qualify as appropriate.

The enclosed documentation is an integral part of this system. Keep the documentation in a convenient place for future reference and observe all instructions contained therein.

2.2 Safety Information

This section contains safety information that must be observed at all times when working on or with the SMA Flexible Storage System. To prevent personal injury and property damage and to ensure long-term operation of the SMA Flexible Storage System, read this section carefully and observe all safety information at all times.

⚠ WARNING

Danger to life from electric shock due to live voltage

High voltages are present in the SMA Flexible Storage System. When covers (e.g., an enclosure lid) are removed, live components can be touched, which can result in death or serious injury due to electric shock.

- When carrying out any work on the electrical installation, wear suitable personal protective equipment.
- Before removing a cover, disconnect the relevant device from voltage sources (see documentation of the relevant device).

Danger to life from electric shock due to damaged components

Operating a damaged device can lead to hazardous situations that can result in death or serious injuries due to electric shock.

- In all cases, only use devices when they are technically faultless and in an operationally safe state.
- Regularly check all devices for visible damage.
- Ensure that all safety equipment is freely accessible at all times.
- Make sure that all safety equipment is in good working order.

Danger to life due to incompatible lithium-ion battery

An incompatible lithium-ion battery can lead to a fire or an explosion. With incompatible lithium-ion batteries, it is not ensured that the battery management is intrinsically safe and will protect the battery.

- Verify that the battery complies with locally applicable standards and directives, and is intrinsically safe.
- Ensure that the lithium-ion batteries are approved for use with the Sunny Island.

The list of lithium-ion batteries approved for the Sunny Island is updated regularly (see the Technical Information "List of Approved Lithium-Ion Batteries" at www.SMA-Solar.com).

- If no lithium-ion batteries approved for the Sunny Island can be used, use lead-acid batteries.

Danger to life due to explosive gases

Explosive gases may escape from the battery and cause an explosion. This can result in death or serious injury.

- Protect the battery environment from open flames, embers, or sparks.
- Install, operate, and maintain the battery in accordance with the manufacturer's specifications.
- Do not heat the battery above the temperature permitted or burn the battery.
- Ensure that the battery room is sufficiently ventilated.
- Remove watches, rings, and other metal objects.
- Use insulated tools.
- Do not place tools or metal parts on the battery.

⚠ WARNING**Chemical burns and poisoning due to battery electrolyte**

If handled inappropriately, battery electrolyte can cause irritation to the eyes, respiratory system, and skin, and it can be toxic. This may result in blindness and serious chemical burns.

- Protect the battery enclosure against destruction.
- Do not open or deform the battery.
- Whenever working on the battery, wear suitable personal protective equipment such as rubber gloves, apron, rubber boots, and goggles.
- Rinse acid splashes thoroughly with clear water and consult a doctor.
- Install, operate, maintain, and dispose of the battery according to the manufacturer's specifications.

Risk of injury due to short-circuit currents

Short-circuit currents in the battery can cause heat build-up and electric arcs. Burns or eye injuries due to flashes may result.

- Remove watches, rings, and other metal objects.
- Use insulated tools.
- Do not place tools or metal parts on the battery.

⚠ CAUTION**Risk of burns due to short-circuit currents on the disconnected Sunny Island**

The capacitors store energy at the DC connection input area. After the battery is isolated from the Sunny Island, battery voltage is still temporarily present at the DC terminal. A short circuit at the DC connection can lead to burns and may damage the Sunny Island inverter.

- Wait 15 minutes before performing any work at the DC connection or on the DC cables. This allows the capacitors to discharge.

NOTICE**Damage to the battery due to incorrect settings**

The set battery parameters influence the charging behavior of the Sunny Island inverter. The battery can be damaged by incorrect settings of the parameters for battery type, nominal voltage, and capacity.

- Ensure that the values recommended by the battery manufacturer are set (refer to the technical data of the battery in the manufacturer documentation). Note that the battery charging behavior names used by SMA Solar Technology AG and the battery manufacturer may, in some cases, differ in meaning (for the battery charging behavior of the Sunny Island inverter, see technical information "Battery Management").
- Set the battery capacity for a ten-hour electric discharge (C10) The battery manufacturer specifies the battery capacity in relation to discharge time.

Destruction of devices due to electrostatic discharge (ESD)

If enclosure parts are removed, the devices (e.g., Sunny Island or PV inverter) can be damaged or destroyed if electronic components or terminals are touched.

- Do not touch any electronic components in open devices.
- Ground yourself before touching any connections.

3 Information and System Description

3.1 Requirements of the "VDE Forum Network Technology / Network Operations (FNN)"

The information below only applies for systems for which the following properties are all applicable:

- Only one Sunny Island is connected in the system.
- The grid operator requires compliance with the Technical Information "Connection and Operation of Storage Units" of the FNN. Currently, only the grid operators in Germany require compliance with the above-mentioned Technical Information (status: June 2014).

In these systems, the Sunny Island must be connected to a line conductor supplied by a single-phase PV inverter. If there are only three-phase PV inverters connected in the system, the Sunny Island can be connected to any line conductor.

The requirements of the Technical Information "Connection and Operation of Storage Units in Low-Voltage Networks" published by the FNN influence the discharge behavior of the Sunny Island inverter. In systems with one Sunny Island and single-phase PV inverters, the SMA Flexible Storage System reduces the maximum discharge power of the Sunny Island inverter as required.

Example 1:

All PV inverters are single-phase and are feeding in asymmetrically (Sunny Boy). The PV inverters are connected to one line conductor.

The Sunny Island must be connected to the line conductor into which the PV inverters are feeding.

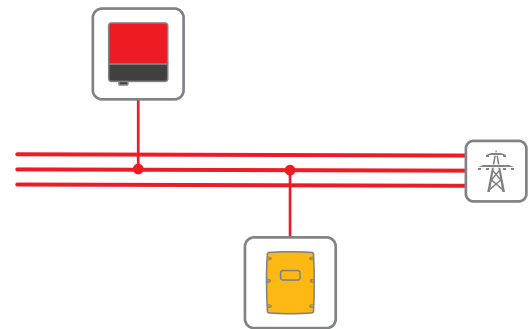

Example 2:

All PV inverters are single-phase and are feeding in asymmetrically (Sunny Boy). PV inverters are connected to two line conductors.

The Sunny Island must be connected to a line conductor into which a single-phase PV inverter is feeding. TIP: Connect the Sunny Island to the line conductor being supplied with the least PV energy. This will increase the control range for increased self-consumption.

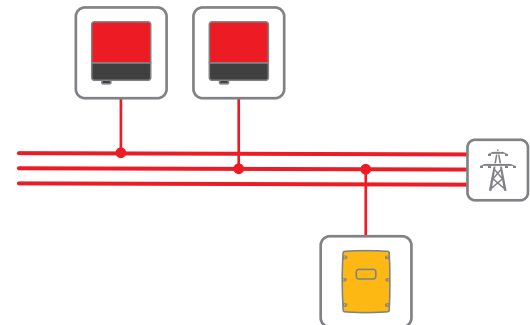

Example 3:

All PV inverters are single-phase and are feeding in asymmetrically (Sunny Boy). One PV inverter is connected to each line conductor.

The Sunny Island can be connected to any line conductor. TIP: Connect the Sunny Island to the line conductor being supplied with the least PV energy. This will increase the control range for increased self-consumption.

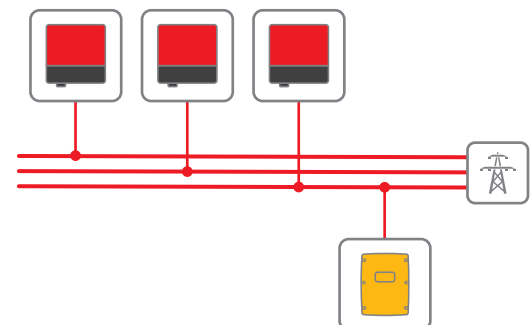

Example 4:

All PV inverters are three-phase and are feeding in symmetrically (Sunny Tripower).

The Sunny Island can be connected to any line conductor.

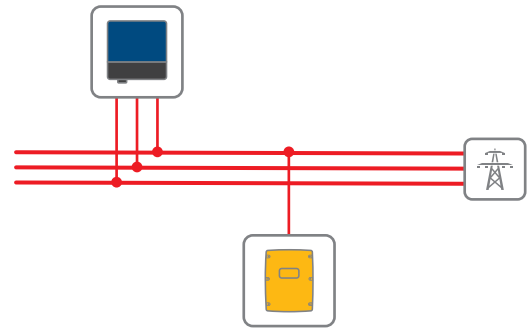
**Example 5:**

The PV system consists of three-phase PV inverters (Sunny Tripower) and single-phase PV inverters (Sunny Boy). The PV system is feeding in asymmetrically.

The Sunny Island must be connected to a line conductor into which a single-phase PV inverter is feeding.

The PV system is not ideal for the SMA Flexible Storage System. The Sunny Island can only discharge the battery if less than 4.6 kVA are being fed in on the line conductor of the Sunny Island inverter at the point of interconnection.

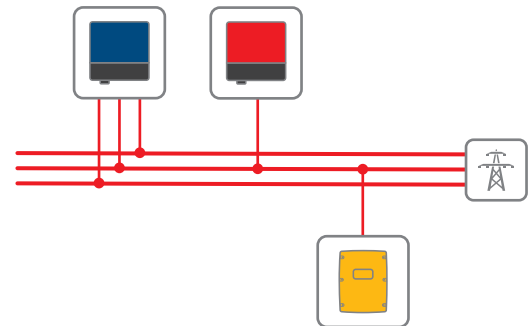

3.2 Requirements of VDE Application Guide 2510-2

The requirements below only apply for systems for which the following properties are all applicable:

- The system is a self-consumption system and/or battery-backup system.
- The system is installed in Germany.

In accordance with the scope of the VDE application guide 2510-2, a manufacturer's system is regarded as a complete energy storage system only if products are used that have been approved by the manufacturer (for details on the SMA Flexible Storage System of SMA Solar Technology AG see the Planning Guidelines "SMA Smart Home" and the Technical Information "List of Approved Lithium-Ion Batteries" at www.SMA-Solar.com). If products are used that have not been approved by SMA Solar Technology AG, the installer is deemed as the manufacturer of the system.

The requirements of the VDE application guide 2510-2 are fulfilled if the installation is carried out in the accordance with the technical documentation of the Sunny Island inverter.

3.3 System Information

i Recommendations for battery capacity

SMA Solar Technology AG recommends the following minimum battery capacities. The battery capacities apply for a ten-hour electric discharge (C10).

- System with one Sunny Island: 100 Ah
- System with three Sunny Island inverters: 300 Ah

Connecting the Sunny Island inverter

At terminal **AC2**, there are two terminals **N** and **N_{TT}** for the connection of the neutral conductor.

- Always connect the neutral conductor to the **N_{TT}** terminal at the terminal **AC2** in systems for increased self-consumption. This ensures that the Sunny Island disconnects at all poles.

Device Types within a Cluster

All Sunny Island inverters must be of the same device type.

Requirements for the router and network switches for Speedwire devices

- All Speedwire devices must be connected to the same router.
- The router and optionally one or more network switches must fully support Multicast.
- The router must support "Internet Enabled Devices" with the interfaces SIP and STUN.

The most common routers and network switches support Multicast and "Internet Enabled Devices".

i The Sunny Home Manager does not support wind power inverters or CHP plants

The Sunny Home Manager only supports PV inverters. If your system combines various AC power sources (e.g., PV system and small wind turbine system), the Sunny Home Manager can only detect the PV inverters and limit their power. In the Sunny Home Manager system, no wind power inverters or CHP plants are displayed in Sunny Portal. Since the data from wind power inverters or CHP plants is not taken into account by the Sunny Home Manager, the data calculated in Sunny Portal and the displayed diagrams may be inaccurate. However, you have the option of displaying the wind power inverters via the Sunny Explorer software and configuring them if necessary (see documentation of Sunny Explorer).

3.4 System Description

The SMA Flexible Storage System supports increased self-consumption through the following measures:

- Intermediate storage of excess PV energy with Sunny Island
- Load control and PV system monitoring with Sunny Home Manager

The Sunny Island uses the connected battery for the intermediate storage of excess PV energy. The Sunny Island measures the grid feed-in and the purchased electricity with the SMA Energy Meter or via the energy meter on the Sunny Home Manager. The battery management uses this data to regulate the charging and discharging of the battery. The grid feed-in and the purchased electricity are transmitted to the Sunny Island via Speedwire. To enable this, the Sunny Island must be fitted with the Speedwire data module Sunny Island.

The Sunny Home Manager receives location-based weather forecasts via the Internet and uses these to create a production forecast for the PV system. In addition, the Sunny Home Manager determines how much energy is typically consumed in a household at different times of the day and uses this to create a load profile of the household. The Sunny Home Manager uses the production forecast and the load profile to determine favorable times for increased self-consumption and selectively switches, for example, the loads connected to the SMA radio-controlled sockets on and off. If required by the grid operator, the Sunny Home Manager also monitors the active power feed-in of the PV system. If the set maximum value for active power feed-in is exceeded, the Sunny Home Manager sends power reduction commands to the SMA PV inverters. The PV system can consist of PV inverters with BLUETOOTH communication and PV inverters with Speedwire communication.

Prevention of derating losses

The SMA Flexible Storage System prevents derating losses which may arise due to the limitation of active power feed-in. This is achieved by regulating the operation times of time-independent loads and the time and duration of battery charging in accordance with the PV production forecast and the consumption forecast.

Example: The current daily forecast of the system predicts a limitation of active power feed-in around noon when the energy requirement of the loads is very low and PV production is high. For this reason, derating losses can be expected. According to this forecast, the system only begins to charge the battery in the late morning. The derating losses will be reduced or avoided by charging the battery at this later time. The total excess PV energy generated in the morning will be fed into the utility grid without derating losses (for details on power control, see Planning Guidelines "SMA Smart Home").

Deactivation of the increased self-consumption function during certain charging procedures

To increase the service life of the battery, the SMA Flexible Storage System regularly carries out full and equalization charges (see the Technical Information "Battery Management" at www.SMA-Solar.com). During this charging process, the increased self-consumption function is deactivated and electricity may have to be purchased to perform the full and equalization charges.

4 System With One Sunny Island

4.1 Circuitry Overview

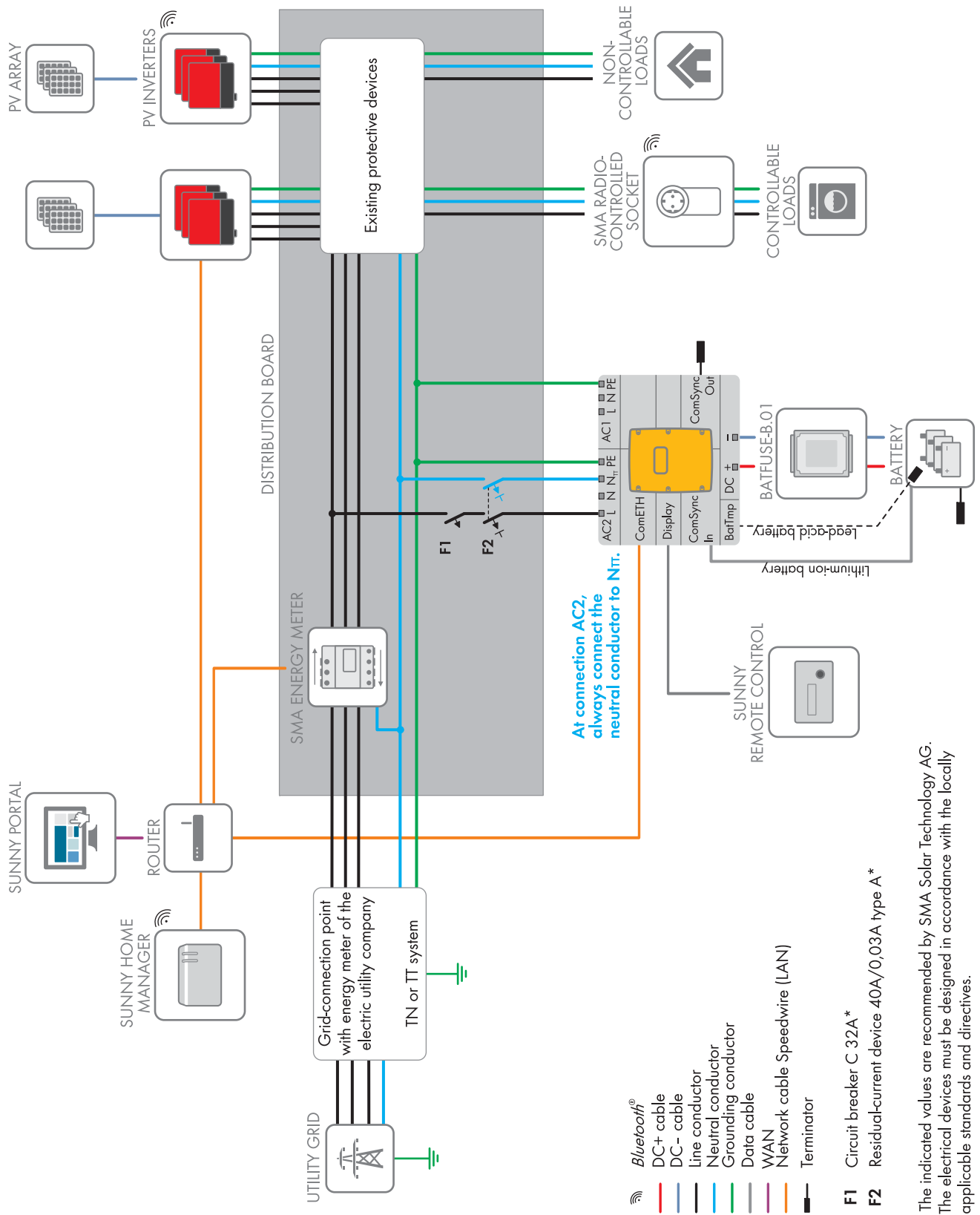

Figure 1: Circuitry of the SMA Flexible Storage System for TN and TT systems

4.2 Connecting the Sunny Island

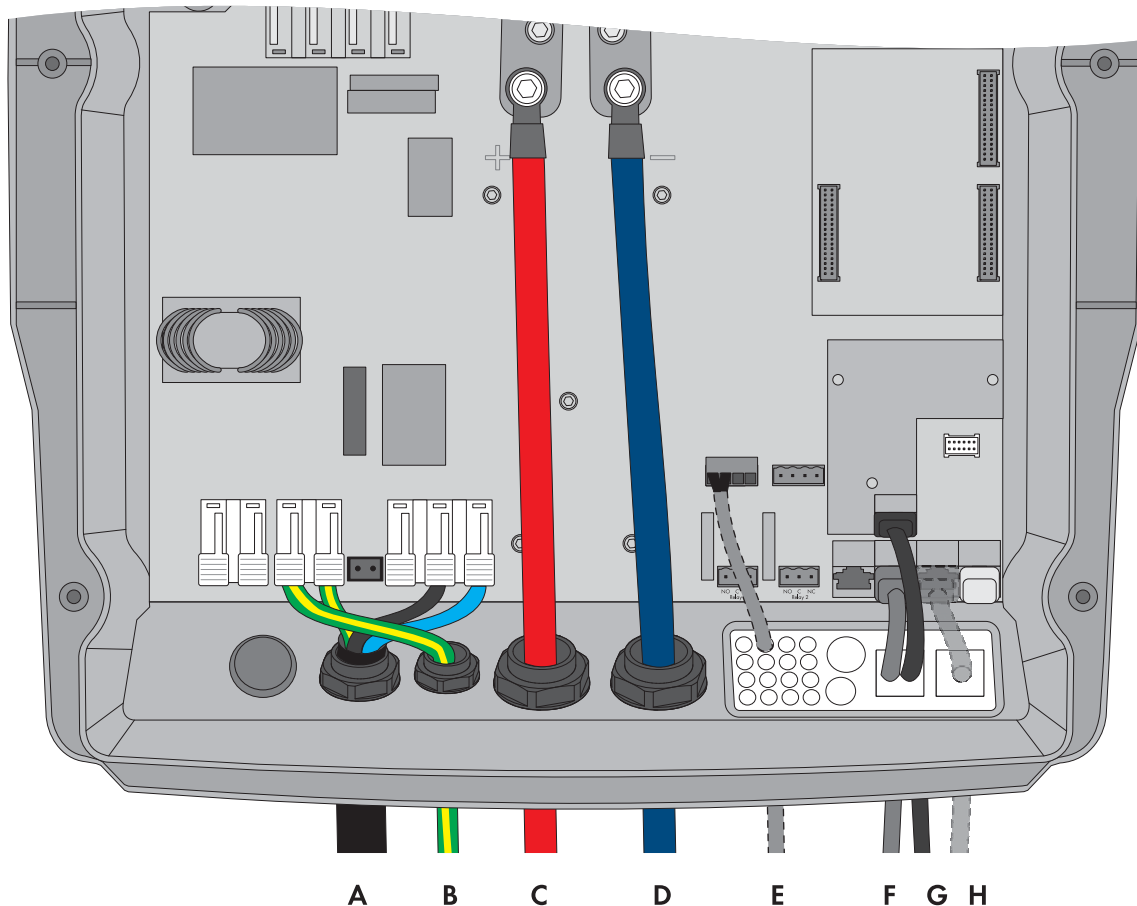

Figure 2: Connecting the Sunny Island inverter

Position	Designation	Description / information
A	AC power cable	Terminal AC2 Gen/Grid , terminals L , N_{TT} und PE Utility grid connection with a three-wire cable Conductor cross-section: 6 mm ² to 16 mm ²
B	Grounding conductor	Terminal AC1 Loads/SunnyBoys , terminal PE Additional grounding if the conductor cross-section of the AC power cable is less than 10 mm ² . The conductor cross-section must equal at least the conductor cross-section of the AC power cable.
C	DC+ cable	Battery terminal
D	DC – cable	Conductor cross-section: 50 mm ² to 95 mm ² Cable diameter: 14 mm to 25 mm Torque: 12 Nm
E	Measuring cable of the battery temperature sensor	Terminal BatTmp You only have to connect a battery temperature sensor if lead-acid batteries are used. Mount the battery temperature sensor in the middle of the battery terminal, in the upper third of the battery cell.

Position	Designation	Description / information
F	Data cable to Sunny Remote Control	Terminal Display
G	Speedwire network cable	Terminal ComETH In order to connect the router/network switch, the Speedwire data module Sunny Island must be mounted in the Sunny Island (see Sunny Island Speedwire data module installation manual). The terminal ComETH is on the data module.
H	Data cable to lithium-ion battery	Terminal ComSync In Connection of the battery management of the lithium-ion battery The communication bus must be connected to the lithium-ion battery and the terminator must remain plugged into the terminal ComSync Out .

5 System With Three Sunny Island Inverters

5.1 Circuitry Overview

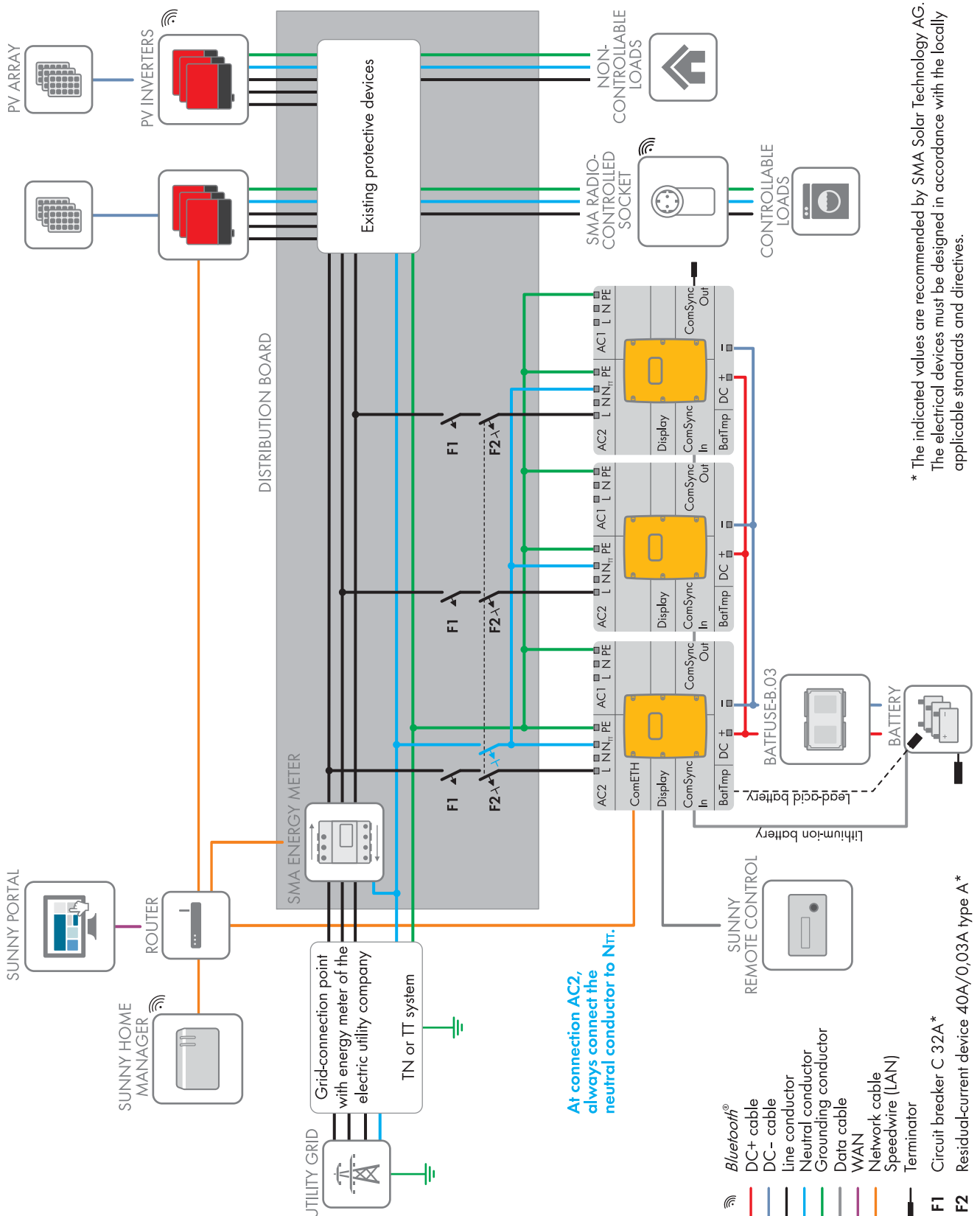

Figure 3: SMA Flexible Storage System for TN and TT systems

5.2 Connecting the Master

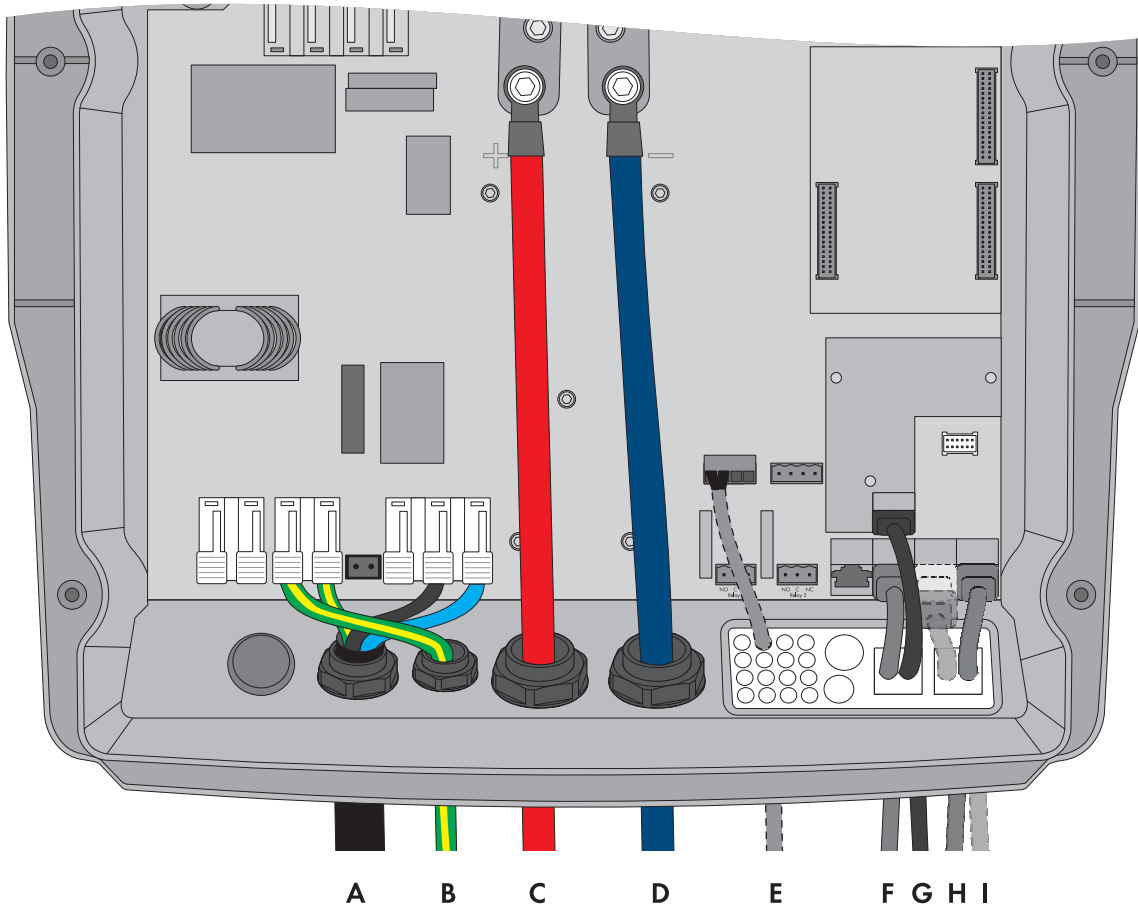

Figure 4: Connecting the master

Position	Designation	Description / information
A	AC power cable	Terminal AC2 Gen/Grid , terminals L , N_{TT} und PE Utility grid connection with a three-wire cable to the line conductor L1 Conductor cross-section: 6 mm ² to 16 mm ²
B	Grounding conductor	Terminal AC1 Loads/SunnyBoys , terminal PE Additional grounding if the conductor cross-section of the AC power cable is less than 10 mm ² The conductor cross-section must equal at least the conductor cross-section of the AC power cable.
C	DC+ cable	Battery terminal
D	DC – cable	Conductor cross-section: 50 mm ² to 95 mm ² Cable diameter: 14 mm to 25 mm Torque: 12 Nm
E	Measuring cable of the battery temperature sensor	Terminal BatTmp You only have to connect a battery temperature sensor if lead-acid batteries are used. Mount the battery temperature sensor in the middle of the battery terminal, in the upper third of the battery cell.

Position	Designation	Description / information
F	Data cable to Sunny Remote Control	Terminal Display
G	Speedwire network cable	Terminal ComETH In order to connect the router/network switch, the Speedwire data module Sunny Island with the terminal ComETH must be mounted in the Sunny Island (see Speedwire data module Sunny Island installation manual).
H	Data cable to lithium-ion battery	Terminal ComSync In Connection of the battery management of the lithium-ion battery The communication bus must be connected to the lithium-ion battery. If no lithium-ion batteries are used, plug the terminator into the terminal ComSync In .
I	Data cable for the internal communication in the cluster	Terminal ComSync Out Connection of internal communication bus of slave 1

5.3 Connecting Slave 1 and Slave 2

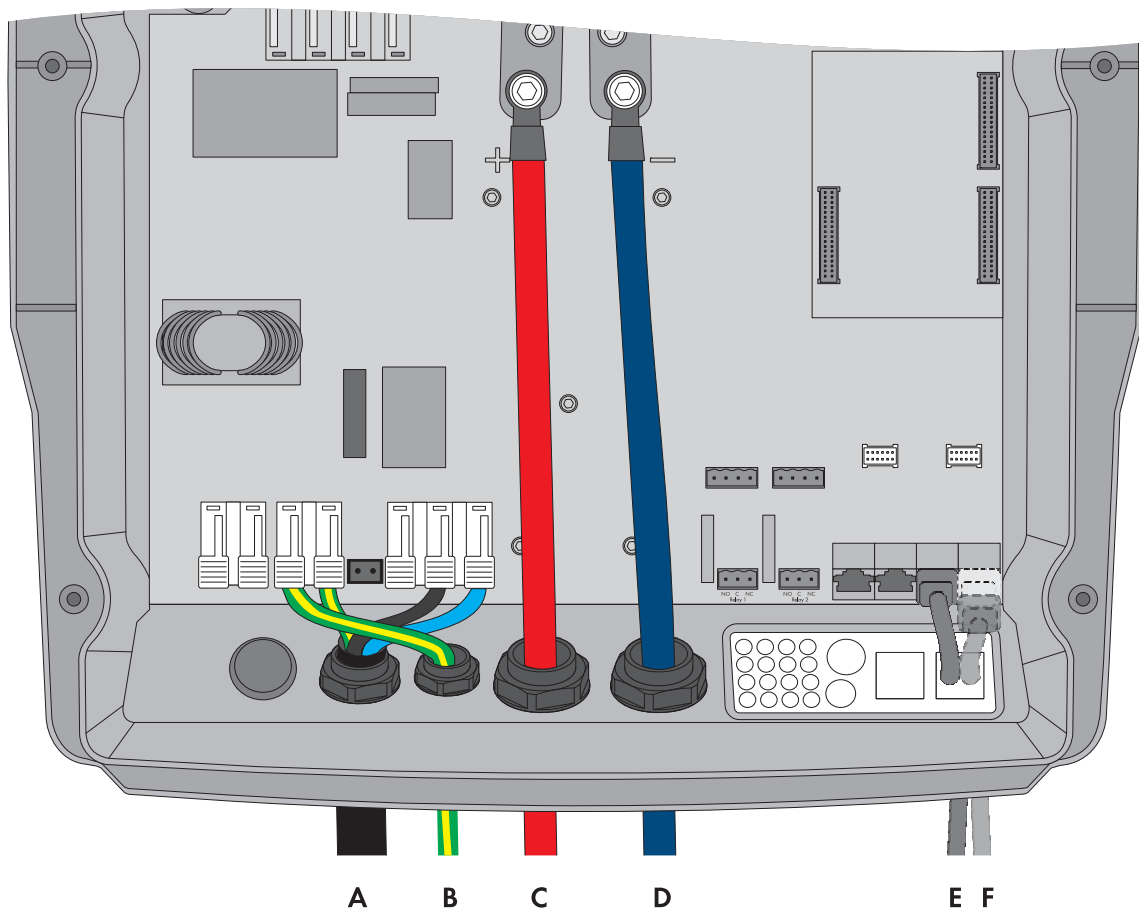

Figure 5: Connecting the Sunny Island inverter

Position	Designation	Description / information
A	AC power cable	Terminal AC2 Gen/Grid , terminals L , N_{TT} und PE Utility grid connection with a three-wire cable Connect slave 1 to line conductor L2, connect slave 2 to line conductor L3. Conductor cross-section: 6 mm ² to 16 mm ²
B	Grounding conductor	Terminal AC1 Loads/SunnyBoys , terminal PE Additional grounding if the conductor cross-section of the AC power cable is less than 10 mm ² . The conductor cross-section must equal at least the conductor cross-section of the AC power cable.
C	DC+ cable	Battery terminal
D	DC – cable	Conductor cross-section: 50 mm ² to 95 mm ² Cable diameter: 14 mm to 25 mm Torque: 12 Nm
E	Data cable for the internal communication in the cluster	Terminal ComSync In With slave 1: connection of internal communication bus of master With slave 2: connection of internal communication bus of slave 1
F	Data cable for the internal communication in the cluster	Terminal ComSync Out With slave 1: connection of internal communication bus after slave 2 With slave 2: leave terminator plugged in. Slave 2 is connected to slave 1 only.

6 Connecting the Sunny Home Manager

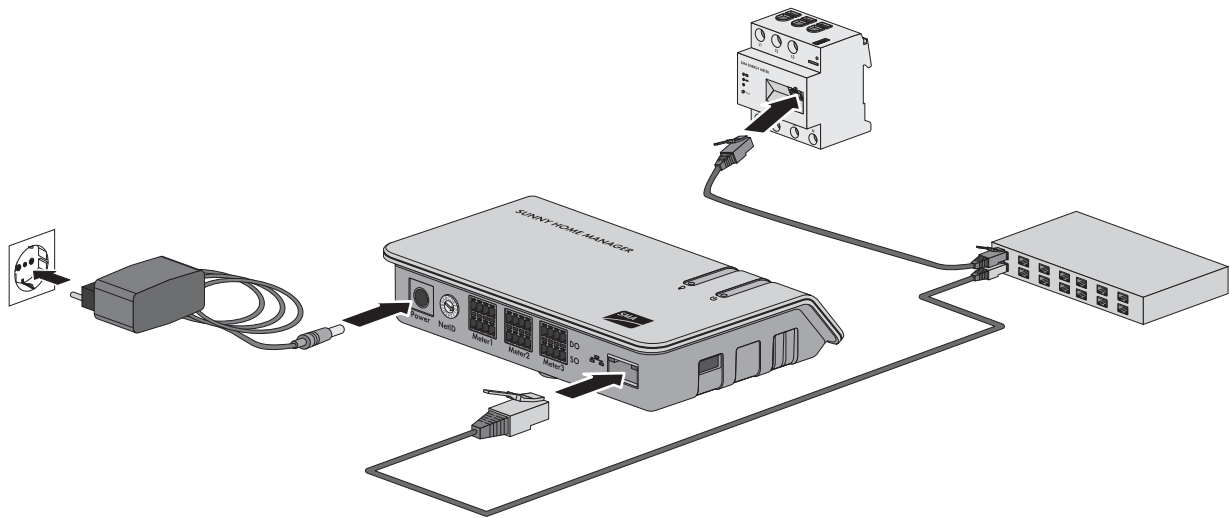

Figure 6: Connecting the Sunny Home Manager

Requirements:

- All Speedwire devices must be connected to the same router.
- The router and the optional network switch must fully support Multicast.
- The router must support "Internet Enabled Devices" with the interfaces SIP and STUN.

The most common routers and network switches support Multicast and "Internet Enabled Devices".

7 Commissioning

7.1 Basic Configuration of the Sunny Island Inverter

NOTICE

Damage to the battery due to incorrect settings

The set battery parameters influence the charging behavior of the Sunny Island inverter. The battery can be damaged by incorrect settings of the parameters for battery type, nominal voltage, and capacity.

- Ensure that the values recommended by the battery manufacturer are set (refer to the technical data of the battery in the manufacturer documentation). Note that the battery charging behavior names used by SMA Solar Technology AG and the battery manufacturer may, in some cases, differ in meaning (for the battery charging behavior of the Sunny Island inverter, see technical information "Battery Management").
- Set the battery capacity for a ten-hour electric discharge (C10) The battery manufacturer specifies the battery capacity in relation to discharge time.

Requirements:

- The SMA Flexible Storage System must be installed in accordance with the circuitry (see Section 4.1 or 5.1).
- With a three-phase system, the Sunny Remote Control must be connected to the master. The master is thus defined during basic configuration.
- The circuit breaker **F1** in the distribution board must be open.

Procedure:

Check the wiring (see the Sunny Island inverter installation manual).



Close all devices except the BatFuse.
This protects all live components from being touched.



Close the BatFuse and switch on all Sunny Island inverters:
In systems with one Sunny Island, press the "On" button.

In systems with three Sunny Island inverters, press and hold the "On" button on the master until an acoustic signal sounds.

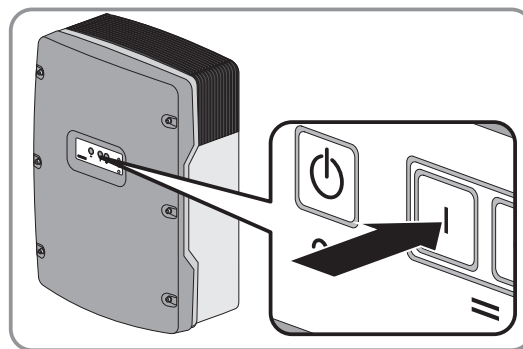

↓

When the Sunny Remote Control shows **<Init System>**, press and hold the button on the Sunny Remote Control.

```

Boot          xxxxxx-xx
              <Init System>#
              xx.xx.xxxx  xx!xx!xx
    
```

An acoustic signal sounds three times and the Sunny Remote Control displays the Quick Configuration Guide.

```

Select option
001#01  [#####]
              StartMenu
              Start System#
    
```

↓

Turn the button on the Sunny Remote Control and select **New System**.

```

Select option
001#01  [#####]
              StartMenu
              New System#
    
```

↓

Press the button. This confirms your selection of **New System**.

An entry confirmation prompt appears.

```

Select option
001#01  <accept Y/N>
              StartMenu
              New System#
    
```

↓

Set **Y** and press the button.

↓

Set the date.

```

Setup new device
003#04  <Set>#
              Dt
              22.02.2012 [d.m.y.]
    
```

↓

Set the time.

```

Setup new device
003#05  <Set>#
              Tm
              15:57:28 [hhmmss]
    
```

↓

Set **OnGrid**.

```

Setup new device
003#06  <Set>#
              ApplSel
              OnGrid
    
```

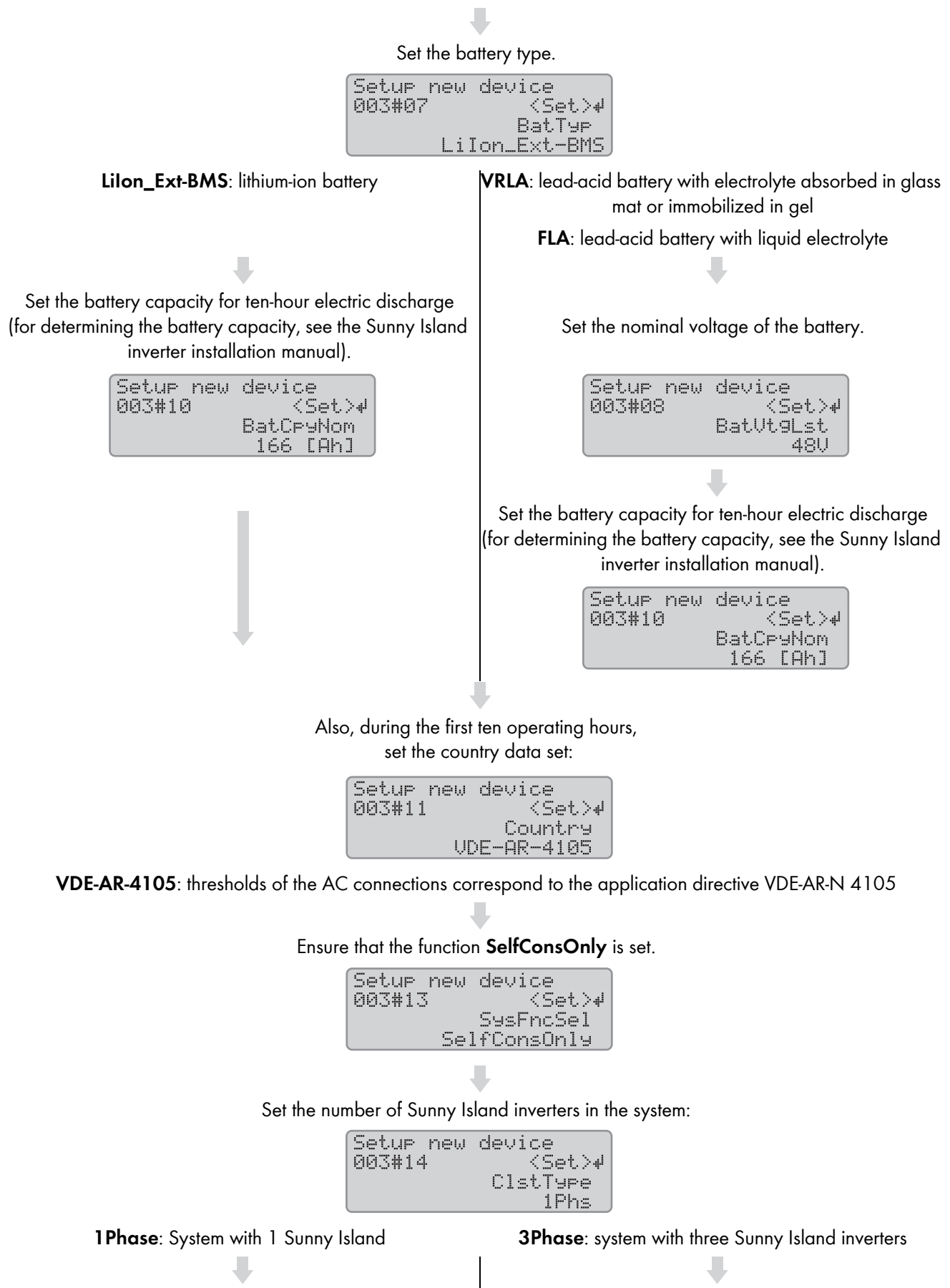

If the country data set of the Sunny Island inverter is **VDE-AR-4105**, set the type of feed-in for the PV system (see Section 3.1, page 10).

```
Setup new system
003#15      <Set>#
           EZAType
           Asymmetric
```

Asymmetric: The installation site is located in Germany and at least one PV inverter feeds in asymmetrically on a single line conductor.

Set the line conductor to which the Sunny Island is connected:

```
Setup new system
003#16      <Set>#
           MsPhSel1
           L1
```

- L1:** connection to line conductor L1
- L2:** connection to line conductor L2
- L3:** connection to line conductor L3

Confirm the basic configuration with **Y**.

```
Setup new system
Done ? <accept Y/N>
```

Symmetric: The installation site is either located outside of Germany or all PV inverters feed in symmetrically on three line conductors.

Confirm the basic configuration with **Y**.

```
Setup new system
Done ? <accept Y/N>
```

The basic configuration is complete.

If an SD memory card is inserted in the Sunny Remote Control, the message **Do not remove MMC/SD memory card ...** appears.

Close the circuit breaker **F1** and the residual-current device **F2** in the distribution board and leave the Sunny Island switched on, but do not start it.

Confirm the basic configuration with **Y**.

```
Setup new system
Done ? <accept Y/N>
```

Wait until the upper LED (inverter LED) on slave 1 is flashing and the Sunny Remote Control is displaying **To identify Slave1, press Tss on the Slv.**

Press the start-stop button on slave 1.

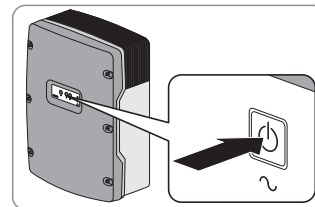

Wait until the upper LED (inverter LED) on slave 2 is flashing and the Sunny Remote Control is displaying **To identify Slave2, press Tss on the Slv.**

Press the start-stop button on slave 2.

7.2 Adjusting the Configuration of the Sunny Island Inverter

7.2.1 Countries in Which the Configuration Must Be Adjusted

In the SMA Flexible Storage System, the Sunny Island inverters are connected to the utility grid and must meet the requirements of the grid operators. The Sunny Island inverters fulfill the requirements of application guide V DE-AR-N 4105:2011-08. In the Sunny Island, this application guide is defined as standard country data set **VDE-AR-4105** (status: September 2016):

- Denmark (see Section 7.2.2, page 26)
- Austria (see Section 7.2.3, page 27)
- Switzerland (see Section 7.2.4, page 27)

The configuration may only be adjusted on request or with permission of the grid operator in the following countries (status: July 2014):

- Belgium
Country data set: VDE-AR-4105
- Germany
Country data set: VDE-AR-4105

Use in other countries is possible with the agreement of the grid operator. Consult the grid operator on whether adjustment is necessary.

7.2.2 Adjusting the Configuration for Denmark

When using the Sunny Island inverter 6.0H / 8.0H in Denmark, you must reduce the discharge/charging current (default setting: max. 20.0 A).

When using the Sunny Island inverter 3.0M / 4.4M in Denmark, you can retain the default setting of the discharge/charging current (default setting: max. 16.0 A).

Requirements:

- The extended configuration must be performed within the first ten operating hours of the Sunny Island inverter, otherwise an SMA Grid Guard code is required in order to change grid-relevant parameters (application form for the SMA Grid Guard code available at www.SMA-Solar.com).
- The country data set of the Sunny Island inverter must be set to **VDE-AR-4105** (see Section 7.1 "Basic Configuration of the Sunny Island Inverter", page 22).

Procedure:

1. Log in to the communication product as **Installer** (see the user manual of the communication product) or switch to expert mode on the Sunny Remote Control (see the Sunny Island operating manual).
2. Set the parameter **Maximum AC battery charging current** or **210.03 InvChrgCurMax** to **16,0 A**.

7.2.3 Adjusting the Configuration for Austria

If your grid operator does not permit frequency-dependent control of active power feed-in in the case of overfrequency, you must switch off this function (see VDE-AR-N 4105 item 5.7.3.3). If your grid operator specifies a maximum grid feed-in per line conductor, you must reduce the discharge/charging current (default setting in the Sunny Island is max. 20.0 A).

Requirements:

- The extended configuration must be performed within the first ten operating hours of the Sunny Island inverter, otherwise an SMA Grid Guard code is required in order to change grid-relevant parameters (application form for the SMA Grid Guard code available at www.SMA-Solar.com).
- The country data set of the Sunny Island inverter must be set to **VDE-AR-4105** (see Section 7.1 "Basic Configuration of the Sunny Island Inverter", page 22).

Procedure:

1. Log in to the communication product as **Installer** (see the user manual of the communication product) or switch to expert mode on the Sunny Remote Control (see the Sunny Island operating manual).
2. If frequency-dependent control of active power feed-in is not permitted, set the parameter **Operating mode of active power limitation in the case of overfrequency P(f)** or **232.41 P-WCtLHzMod** to **Off**.
3. If your grid operator specifies a maximum grid feed-in per line conductor, set the parameter **Maximum AC battery charging current** or **210.03 InvChrgCurMax** to the value specified by the grid operator.

7.2.4 Adjusting the Configuration for Switzerland

The following limiting values must be adjusted in order to meet the requirements of the grid operators in Switzerland:

- Maximum power frequency
- The upper frequency difference for valid grid connection
- Minimum observation time for grid voltage and frequency in the permissible range for grid connection

If your grid operator specifies a maximum grid feed-in per line conductor, you also must reduce the discharge/charging current (default setting in the Sunny Island is max. 20.0 A).

In addition, the label enclosed in the delivery must be affixed to the device to indicate that the Sunny Island is set in accordance with DIN VDE 0126-1-1.

Requirements:

- The extended configuration must be performed within the first ten operating hours of the Sunny Island inverter, otherwise an SMA Grid Guard code is required in order to change grid-relevant parameters (application form for the SMA Grid Guard code available at www.SMA-Solar.com).
- The country data set of the Sunny Island inverter must be set to **VDE-AR-4105** (see Section 7.1 "Basic Configuration of the Sunny Island Inverter", page 22).
- The Sunny Remote Control must be connected to the Sunny Island inverter.

Procedure:

1. Switch to expert mode on the Sunny Remote Control (see the Sunny Island operating manual).
2. Set the parameter **232.07 GdFrqMax** to **50.2 Hz**.
3. Set the parameter **232.15 GdFrqMaxDel** to **0.05 Hz**.
4. Set the parameter **232.08 GdVldTm** to **30 s**.
5. If your grid operator specifies a maximum grid feed-in per line conductor, set the parameter **210.03 InvChrgCurMax** to the value specified by the grid operator.
6. Attach the label "VDE 0126-1-1" next the type label of the Sunny Island inverter.

7.3 Preparing BLUETOOTH Communication

To enable communication between SMA BLUETOOTH devices in the SMA Flexible Storage System, all devices must be set to the same NetID (identification number for SMA Bluetooth network). The NetID is used to distinguish between systems with SMA BLUETOOTH operating in close proximity to one another.

Procedure:

1. For PV inverters with integrated BLUETOOTH interface that communicate via Speedwire, set NetID **0** (see PV inverter installation manual). This deactivates communication via BLUETOOTH.
2. Determine the NetID of the BLUETOOTH system:
 - Install Sunny Explorer on a computer. Either run the installation file on the CD provided or download free of charge at www.SMA-Solar.com.
 - Determine a free NetID for the BLUETOOTH system using Sunny Explorer (see Sunny Explorer user manual).
 - Quit Sunny Explorer. This will ensure that the BLUETOOTH network is set up via the Sunny Home Manager.
3. Set the determined NetID on the Sunny Home Manager and on all devices with active BLUETOOTH interface (see documentation of the BLUETOOTH devices). Note that the NetID must not be set to **1** if the Sunny Home Manager is intended to communicate with more than one BLUETOOTH node.

7.4 Commissioning the SMA Flexible Storage System

Required data for registration in Sunny Portal:

Device / customer data	Required data and explanation
Sunny Home Manager	<ul style="list-style-type: none"> • Serial number (PIC) and registration ID (RID) Register the new system in Sunny Portal using the PIC and RID.
SMA Energy Meter	<ul style="list-style-type: none"> • Only when two SMA Energy Meters are installed, note down the serial number and purpose (e.g., PV production meter) in each case. This way you can identify the energy meters in the Sunny Portal.
PV inverters	<ul style="list-style-type: none"> • System password The PV system password is the same as the device password for the user group "Installer". All devices in a PV system must be set to the same password (for user groups and security concept, see the Sunny Explorer user manual). The default password is 1111. • Serial number of the PV inverters You can uniquely identify the PV inverters in Sunny Portal using the serial number. • PV array power in kWp
SMA Radio-Controlled Socket	<ul style="list-style-type: none"> • The serial number and connected load of each SMA radio-controlled socket In Sunny Portal, configure the SMA radio-controlled socket in accordance with the requirements of the connected load. To do so, you require the serial number of the SMA radio-controlled socket.

Device / customer data	Required data and explanation
Customer data	<ul style="list-style-type: none"> • E-mail address • Password for Sunny Portal access • Address of the PV system • Electricity tariff data <ul style="list-style-type: none"> - Electricity price for purchased electricity - Tariff times, if applicable (e.g., for tariffs with peak and off-peak tariff) - Feed-in tariff - Self-consumption tariff, if applicable

Forecast-based battery charging:

The screenshot shows the Sunny Portal interface for configuring a Sunny Home Manager device. The left sidebar contains navigation options like 'PV System Selection', 'Christians Smart Hom...', 'PV System Overview', 'PV System Profile', 'Current Status and Forecast', 'Energy Balance', 'Load Balance and Control', 'Annual Comparison', 'PV System Monitoring', 'PV System Logbook: 47', 'Analysis', 'Neue Seite', 'Report (3)', and 'Geräte (4)'. The 'Configuration' section is expanded, showing 'PV System Properties', 'PV System Presentation', and 'Device Overview'. The main content area is titled 'Device Characteristics' and includes fields for 'Device Class', 'Product Group', 'Serial Number', 'Manufacturer', 'Device Name', and 'Description'. Below these are settings for 'Data Request Interval' (automatic, hourly, daily), 'Time Zone', 'PV System Password', 'Repeat Password', and 'Automatic updates' (Sunny Home Manager, PV system devices). A green box highlights the 'Storage management via the Home Manager' checkbox, which is checked and labeled 'Active'.

Figure 7: User interface of Sunny Portal with **Forecast-based battery charging** checkbox.

When commissioning the SMA Flexible Storage System, you can activate the **Forecast-based battery charging** checkbox in the user interface of Sunny Portal (information on forecast-based charging see Planning Guidelines "SMA Smart Home").

Requirements:

- The SMA Flexible Storage System must be installed in accordance with the circuitry overviews.
- The Sunny Home Manager, the Sunny Island and all other Speedwire devices must be connected to the same router.
- The basic configuration of the Sunny Island inverter must have been performed (see Section 7.1).
- DHCP must be enabled for the router of the system.
- The router of the system must have an Internet connection.

Procedure:

1. In the distribution board, switch on circuit breaker **F1** and residual-current device **F2**.
2. Commission the PV system (see PV inverter documentation).
3. Press the start-stop button on the Sunny Island and hold it until an acoustic signal sounds. This starts the system.

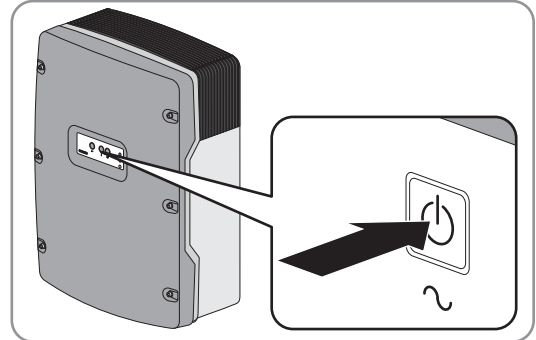

4. Only when two SMA Energy Meters are installed in the local network, assign the grid feed-in meter and purchased electricity meter to the Sunny Island using Sunny Explorer. To do this, enter the serial number of the grid feed-in meter and purchased electricity meter (see the Sunny Explorer user manual).
5. Open Sunny Portal via www.SunnyPortal.com/Register and run the PV System Setup Assistant. The required data for registration in Sunny Portal must be at hand.

i **Representation of the Sunny Island inverters in Sunny Portal**

The Sunny Island inverters will be displayed as one device in Sunny Portal, even if the system consists of three Sunny Island inverters. The data is added together in systems with three Sunny Island inverters.

6. Activate the automatic update of the Sunny Home Manager and the PV system in Sunny Portal.
7. In order to activate the forecast-based charging function, call up the device properties of the Sunny Home Manager in Sunny Portal and activate the **Forecast-based battery charging** checkbox.
8. Only in systems with active power limitation, ensure that the limitation of the active power feed-in is configured and functioning in Sunny Portal ("Configuring Active Power Feed-In Limitation", see the User Manual "Sunny Home Manager in Sunny Portal" at www.SunnyPortal.com).

8 Contact

If you have technical problems with our products, please contact the SMA Service Line. We require the following information in order to provide you with the necessary assistance:

- Displayed error message
- Type, serial number, and firmware version of the Sunny Island inverters
- Type, rated capacity, and nominal voltage of the connected battery
- Type, serial number, firmware version, or software version of the connected communication products
- Type, serial number, and firmware version of the PV inverters

Danmark	SMA Solar Technology AG	Belgien	SMA Benelux BVBA/SPRL
Deutschland	Niestetal	Belgique	Mechelen
Österreich	SMA Online Service Center: www.SMA-Service.com	België	+32 15 286 730
Schweiz	Sunny Boy, Sunny Mini Central, Sunny Tripower: +49 561 9522-1499	Luxemburg	
	Monitoring Systems (Kommunikationsprodukte): +49 561 9522-2499	Luxembourg	
	Fuel Save Controller (PV-Diesel Hybridsysteme): +49 561 9522-3199	Nederland	
	Sunny Island, Sunny Backup, Hydro Boy: +49 561 9522-399	Česko	SMA Service Partner TERMS a.s.
	Sunny Central: +49 561 9522-299	Magyarország	+420 387 6 85 111
		Slovensko	
		Polska	SMA Polska +48 12 283 06 66
		Ελλάδα	SMA Hellas AE
		Κύπρος	Αθήνα +30 210 9856666
España	SMA Ibérica Tecnología Solar, S.L.U.	France	SMA France S.A.S.
Portugal	Barcelona +34 935 63 50 99		Lyon +33 472 22 97 00
Bulgaria	SMA Italia S.r.l.	United Kingdom	SMA Solar UK Ltd.
Italia	Milano		Milton Keynes
România	+39 02 8934-7299		+44 1908 304899
United Arab Emirates	SMA Middle East LLC Abu Dhabi +971 2234 6177	India	SMA Solar India Pvt. Ltd. Mumbai +91 22 61713888
대한민국	SMA Technology Korea Co., Ltd. 서울 +82-2-520-2666	ไทย	SMA Solar (Thailand) Co., Ltd. กรุงเทพฯ +66 2 670 6999
South Africa	SMA Solar Technology South Africa Pty Ltd. Cape Town 08600SUNNY (08600 78669) International: +27 (0)21 826 0600	Argentina	SMA South America SPA
		Brasil	Santiago
		Chile	+562 2820 2101
		Perú	

Australia	SMA Australia Pty Ltd. Sydney Toll free for Australia: 1800 SMA AUS (1800 762 287) International: +61 2 9491 4200	Other countries	International SMA Service Line Niestetal 00800 SMA SERVICE (+800 762 7378423)
-----------	--	-----------------	--

SMA Solar Technology

www.SMA-Solar.com

